

Compressibility | HELLA

In many publications dealing with the ECE-R90 test, the word compressibility appears.

But what does this really mean?

The compressibility of a brake lining refers to the degree that a brake lining can be "pressed together"; in other words, tests are run to see how much the brake lining strength alters when subjected to pressure. This is measured in μm . A μm is one thousandth of a mm.

Such a tiny unit illustrates very clearly how little a brake lining can actually be pressed together. Nevertheless, there are quite considerable differences that a driver can hear and experience in various "braking" scenarios.

A high level of compressibility signifies a "soft" lining. On the whole, soft linings are good and they ensure a comfortable style of braking (screeching / rubbing). However, if the linings are too soft, the driver will experience long pedal travel when applying his brakes. This means that he has to press the pedal all the way down in order to achieve the desired braking effect. Something which does not really inspire confidence when braking. Furthermore, after applying the brakes rather fiercely, it is possible that the brake linings grind similarly fiercely, and thus excessively, against the brake discs. In this way increased wear and tear of the brake linings and of the brake discs temporarily occurs and petrol consumption also increases.

Low compressibility, on the other hand, means that the brake lining is "hard". And, logically, the disadvantages caused by linings which are too soft, as described above, are not present in such a case. However, here there is a growing risk that brakes screech and squeal or, when braking at higher speeds, they will begin to rub. The driver and his passengers become aware of these occurrences either as a result of the vibrating steering wheel or by sensing them via the brake pedal. In extreme cases, it is possible to hear the rubbing of the brakes as a kind of humming sound.

The answer is to find the right degree of hardness for the brake lining, irrespective of the vehicle type and its braking system. This can be achieved by carrying out extensive and rather elaborate measurements and by means of test drives.

Illustration of a testing procedure:

The brake lining (2) is laid, friction side down, on a solid, polished and heated steel plate (1). By means of a piston adapter (3) which corresponds to the type of piston used in the brake itself, the measuring piston of the testing device (4) presses the brake lining together. The force with which the lining is pressed together corresponds to a braking pressure of 160 bar. A distance sensor (5) measures how much i.e. how far, the lining can be pressed together. The measurements are carried out at room temperature and when the steel plate is heated to 400°C. The difference to the thickness of the lining can amount to a maximum of 2% at room temperature and a maximum of 5% at a temperature of 400°C.

Diagram:

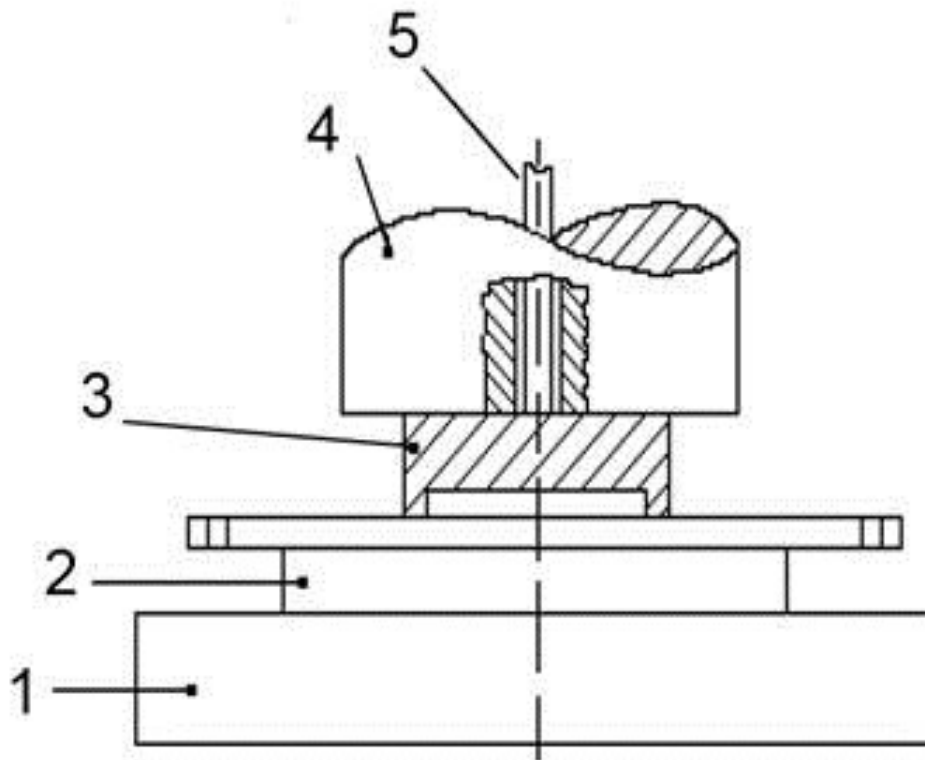

The compressibility values of the brake linings marketed by HELLA are found significantly below the limits stipulated in the ECE-R90 regulations by current legislation.

ⓘ Important safety note

Technical information and practical tips have been compiled by HELLA in order to provide professional support to vehicle workshops in their day-to-day work. The information provided on this website is intended for use by suitably qualified personnel only. Reprinting, distribution, reproduction, exploitation in any form or disclosure of the contents of this document, even in part, is prohibited without our express, written approval and indication of the source. The schematic illustrations, pictures and descriptions serve only for the purposes of explanation and representation of the instructions and cannot be used as a basis for installation or assembly work. All rights reserved.