



VW Touran - fault code 148C/148B and water ingress in the A-pillar area

Data sheet	
Manufacturer	Volkswagen
Vehicle model	Touran with panoramic sunroof
Engine	2.0 TDI
Year of manufacture	2016
Symptoms	Engine control light comes on; water ingress in the area of the A-pillar
Error code	148C / 148B
Recommended HGS tool	mega macs X

Important safety note

Fault code 148C / 148B stored in the fault memory and water ingress in the A-pillar area

The engine control light in the above vehicle type may illuminate although there is no noticeable loss of power. If the above fault occurs and fault codes 148B and 148C (faulty auxiliary heating output stage) are stored in the fault memory, the connecting plugs in the footwell should be checked. They connect the electrical cables of the auxiliary heating, among other things, and are located behind the footwell panelling of the A-pillar on the driver's or passenger's side, depending on the equipment variant.

If moisture or corrosion is detected on the pins of these plug connections, special attention should be paid to the water drains of the panoramic sunroof.

These can become clogged with dirt. The water builds up, flows over the roof cassette into the passenger compartment of the vehicle and enters the plug connections, among other things. To

check this, open the glass roof and pour water directly into the drains. If water builds up in the sunroof cassette and does not drain away immediately, the drains should be cleaned. This can be done, for example, with a cleaning brush that is specially designed for cleaning the water drains.

Once the sunroof drains have been completely cleaned, the damaged pins of the plug connections should also be repaired in order to re-establish a perfect electrical connection.

Once the cause of the fault has been rectified, delete the error memory then carry out a test drive.

This fault profile may also occur in other vehicle models with comparable equipment variants.

i IMPORTANT

Please always follow the repair instructions from the vehicle manufacturer when carrying out such work!

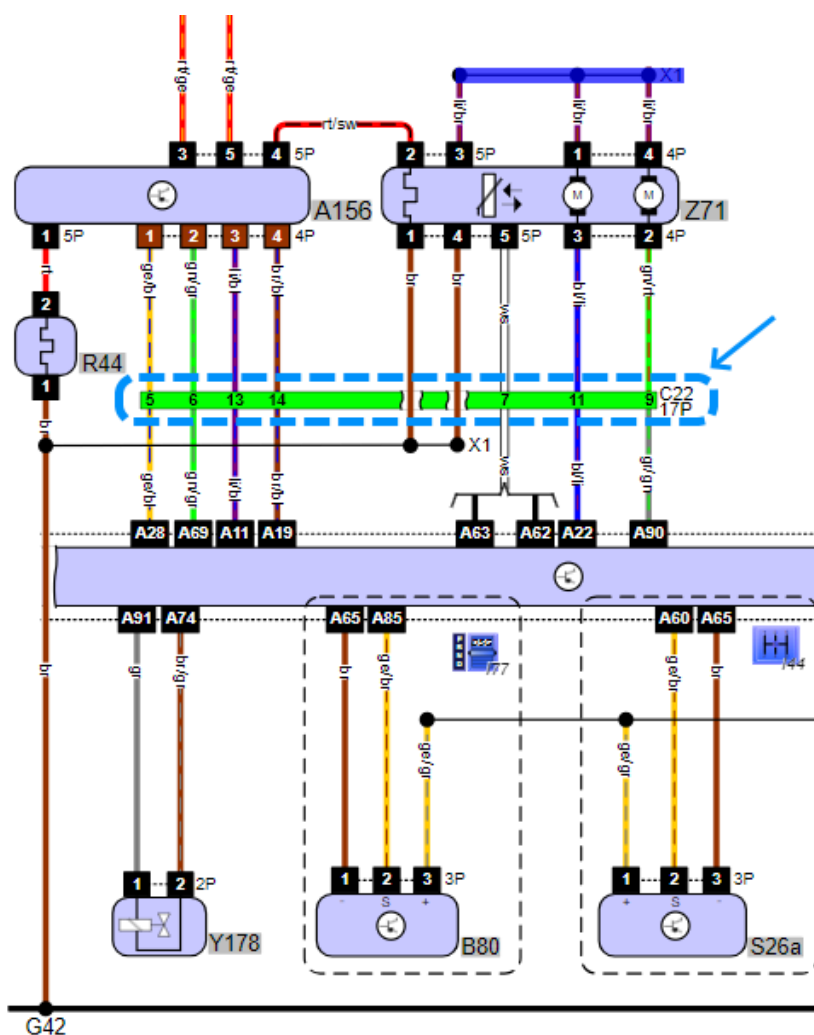

This may also interest you

Reprinting, distribution, reproduction, exploitation in any form whatsoever or disclosure of the contents of this document, even in part, is prohibited unless our express permission has been obtained in writing beforehand and the source is stated. The schematic illustrations, pictures and descriptions are provided for explanatory purposes and are only intended as a visual supplement to the document text, so they cannot be used as the basis for installation or assembly work. All rights reserved.