



VW Golf 5 - poor engine starting behaviour

Data sheet	
Manufacturer	VW
Vehicle model	Golf 5
Engine	1.9 TDI
Engine code	BKC
Year of manufacture	2005 - 2010
Symptoms	Poor engine starting behaviour
Hella spare part	6PP 009 400-471 sensor for intake manifold pressure

Important safety note

Engine starting problems

If the above vehicle model experiences engine starting difficulties regardless of the temperature, one possible cause may be a defective intake manifold pressure sensor.

At the same time, the error code 17036 "Sensor reference voltage B: too low" may be stored in the error memory of the engine control unit. A defective intake manifold pressure sensor can impair the power supply from the engine control unit and thus be responsible for the error memory entry.

In this case, the sensor voltage is to be checked with a suitable measuring device and with the help of a circuit diagram for the vehicle concerned. For the first test step, it is important that the intake manifold pressure sensor is connected to the harness. The sensor voltage, plus and earth, is measured directly on the component and must be 5 volts when the ignition is switched on. If this value is less than 5 volts, the component has to be disconnected from the harness. The supply

voltage is checked once again without connecting the sensor to the harness. If this is now at 5 volts, the sensor is defective and must be replaced (Hella spare part number: 6PP 009 400-471).

Once the cause of the fault has been rectified, delete the error memory and then carry out a test drive.



IMPORTANT

Please always follow the repair instructions from the vehicle manufacturer when carrying out such work.

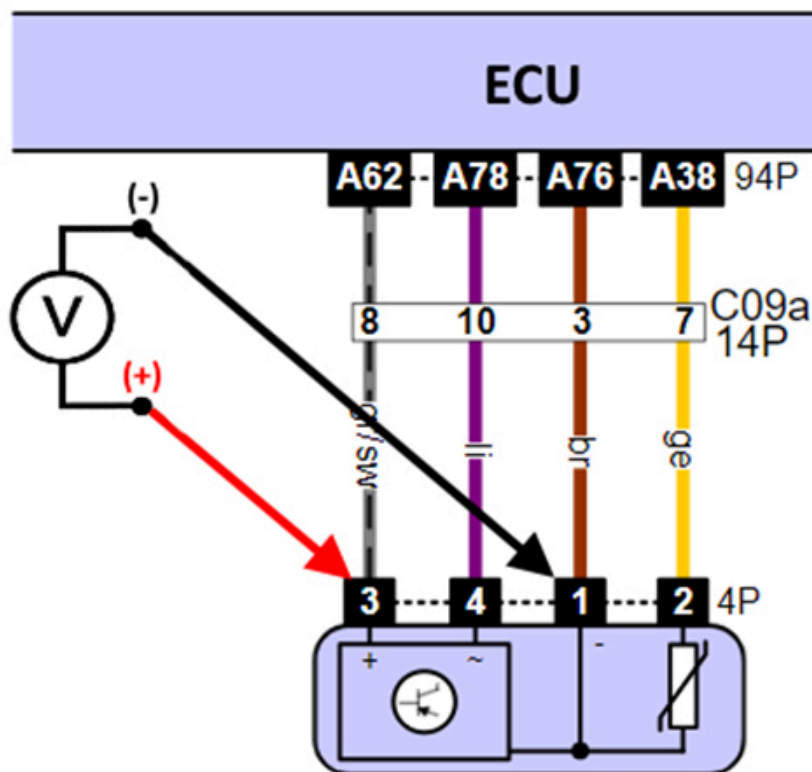



Reprinting, distribution, reproduction, exploitation in any form or disclosure of the contents of this document, even in part, is prohibited without our express, written approval; indication of the document source is also required. The schematic illustrations, pictures and descriptions serve only for the purposes of explanation and representation of the instructions and cannot be used as a basis for installation or assembly work. All rights reserved.