

# Citroen C4 - Illumination of the coolant temperature warning light | HELLA

**Citroen**

**C4**

**All models from 18 September 2006**

**Engine code: NFU (TU5JP4)**

If there are complaints about the illumination of the coolant temperature warning light on the above mentioned vehicles, the coolant temperature sensor is to be considered as a possible source of the fault.

The fault code: P0116 may be logged.

A crack in the measuring element of the coolant temperature sensor may be responsible for the fault, or an incorrect coolant temperature sensor may have been fitted.

Note:

[The coolant temperature sensor is to be checked for the correct specification [(type identifier) marking (\*96566364\* manufacturer Valeo)].

If the measured values are incorrect

(see Technical data / page 2.)

a new, modified coolant temperature

sensor must be fitted to rectify the fault.

Coolant temperature sensor:

Service part number (ET): ET no.: 1338.F8

Hella coolant temperature sensor: 6PT.009 309-221

Temperature sensor - technical data – approximate values

(general information / these figures are not model-specific)

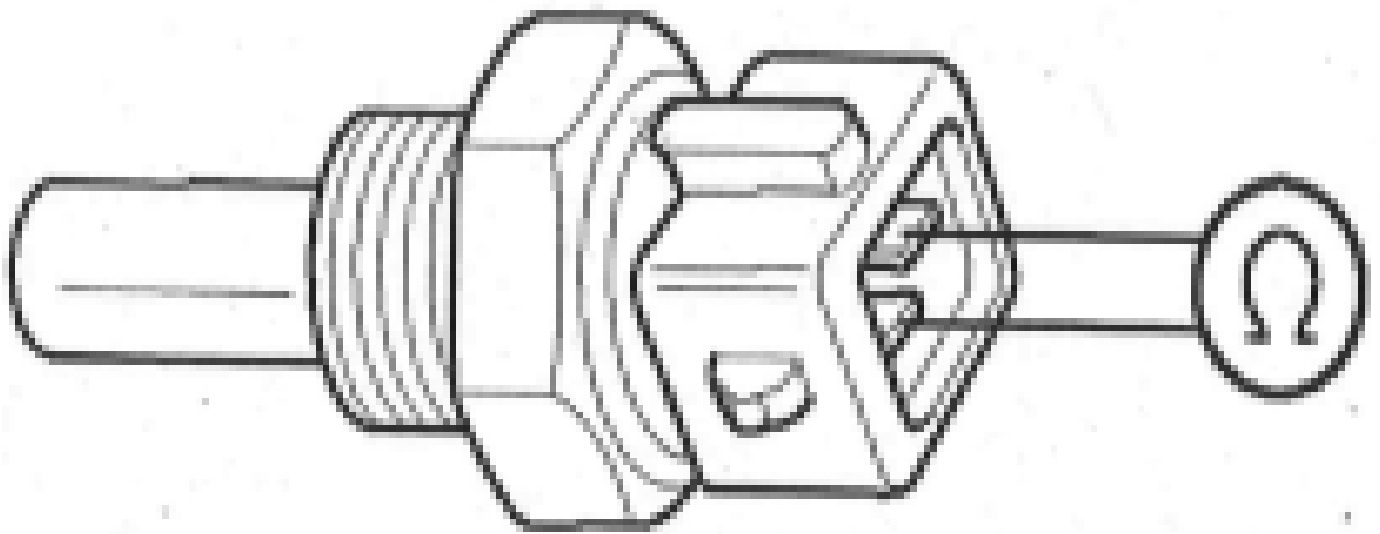

Temperature