



Starters with different numbers of teeth

Data sheet

Spare part

Starter

Please note

Different number of teeth

Important safety note

Different number of teeth on the starter

In everyday workshop life, it is quite likely that, during research for spare parts for a particular vehicle, starters are on offer in different versions with varying amounts of teeth.

This may be due to the fact that components are available from several suppliers within the original equipment sector or it is a result of subsequent product revisions by the spare parts suppliers.

The decisive factor here is not the actual number of teeth, but the shift of the distance between the starter pinion and the ring gear on the vehicle. Depending on the starter pinion, the pinion shaft shifts higher or lower in relation to the starter ring gear.

The difference only becomes visible by looking at the bearing bell.

So if the objective is to replace a starter with 11 teeth with one featuring 12, the pinion shaft is moved further away from the ring gear. The point of contact of both pinions, starter and ring gear remains identical despite the different number of teeth.

This means that if a starter with a different number of teeth is supplied as a replacement, it can be installed without any issues – provided the vehicle has been correctly assigned.

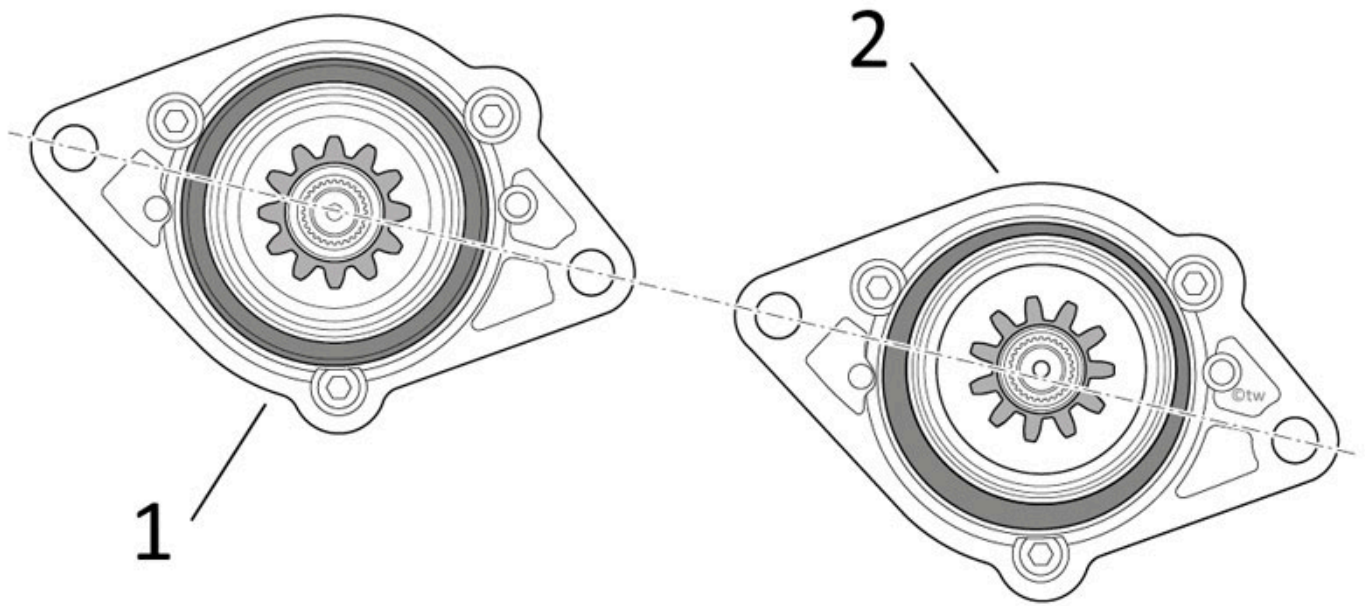

Starter with central (1) and offset (2) pinion position

Reprinting, distribution, reproduction, exploitation in any form or disclosure of the contents of this document, even in part, is prohibited without our express, written approval; indication of the document source is also required. The schematic illustrations, pictures and descriptions serve only for the purposes of explanation and representation of the instructions and cannot be used as a basis for installation or assembly work. All rights reserved.

This may also be of interest to you