

# Renault Espace IV - Renewing brake disc I HELLA

Renault Espace-IV, model year 2002-2014

Renewing brake disc with wheel bearing and ABS impulse ring on rear axle

## Preparing

### Vehicle for repair

- Drive vehicle onto lifting platform
- Deactivate electric parking brake
- Remove rear wheels
- Carry out a visual inspection

Before carrying out the repair, check all relevant components near the axle and wheel brake for damage, such as the tires, transverse control arms and brake hoses !



## Removal

### Removing the brake discs

- Remove retaining spring (1) from brake caliper
- Remove protective plugs (2) from guide bolts
- Inspect protective plugs and damping sleeves (3) for damage
- Undo and remove guide bolts (4)
- Remove brake caliper (5) from brake anchor plate (6) and hang on spring using a suitable hook.

Avoid twisting the brake hose when doing this.

- Remove brake pads
- Slacken and unscrew the fixing screws on the caliper anchor bracket
- Remove brake caliper anchor bracket
- Remove wheel hub cap
- Slacken and unscrew hub nut
- Remove brake disc with wheel hub

Note: To avoid damage, do not leave the brake caliper hanging from the brake hose!

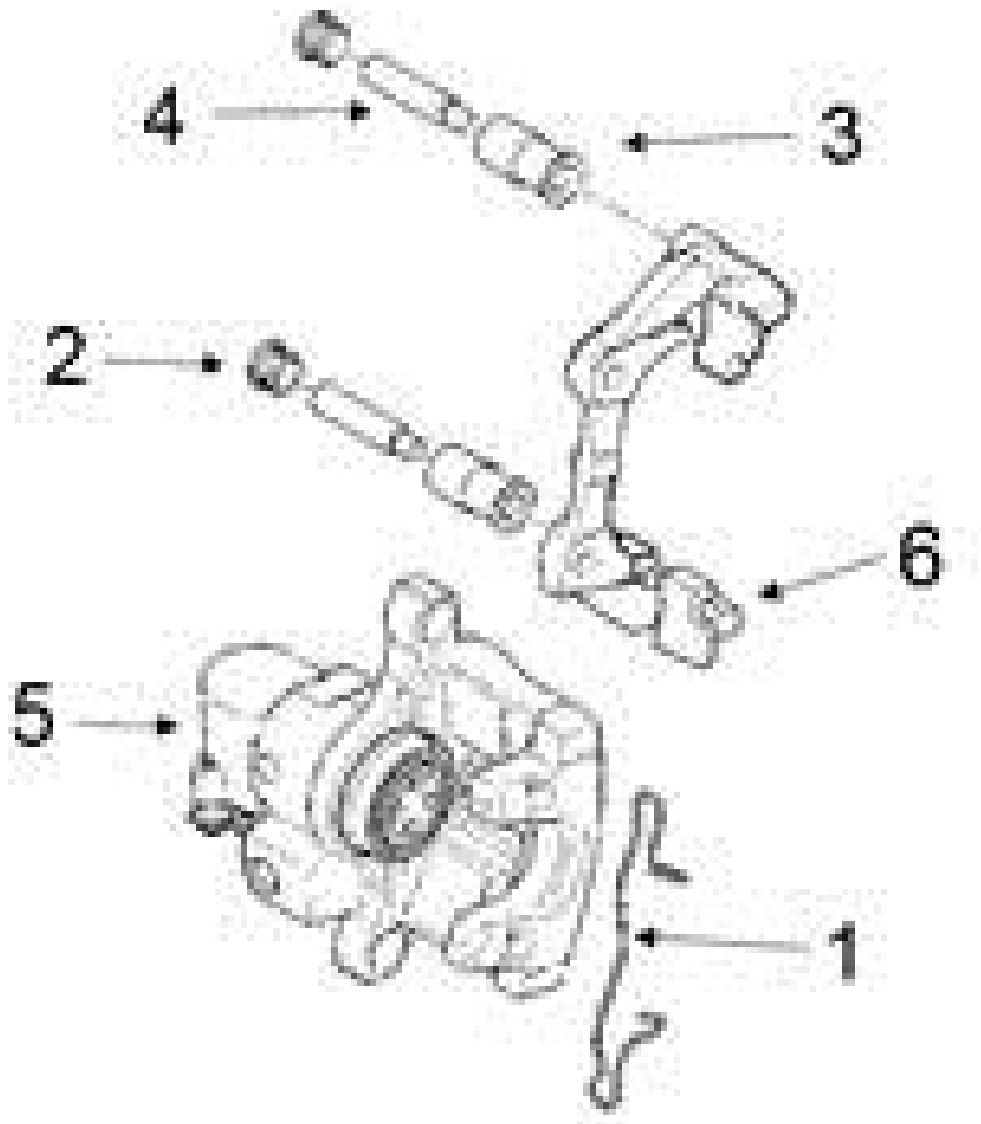

## Cleaning and inspection

Clean the following components and inspect them for damage prior to assembly:

### Brake caliper anchor bracket

- Carefully remove any corrosion from the brake pad contact faces using a wire brush

### Brake caliper

§ Check the dust protection boot of the piston for damage

§ Clean guide bolts and check for damage

§ After cleaning, apply a thin coat of silicone-based grease to the sliding surfaces

## ABS-Sensor

- Check for correct seating and for signs of damage

## Axle journal

- The axle journal should be free of burr, flat and rust-free
- After cleaning, coat the axle journal with a little calibrating oil and spread evenly using a clean cloth

Only clean using brake cleaner, a brush and a lint-free cloth. It is essential to avoid mechanical damage to the guide surfaces.



## Preparations

### Preparing for installation:

- Compare new and old brake discs.
- Check the ABS impulse ring (magnetic coder) installed on the brake disc prior to installation

- Clean brake disc with brake cleaner if necessary
- Check level of brake fluid in expansion tank
- If at the MAX. mark, unscrew cover from brake fluid tank and extract a little fluid



## Installation

### Installing the brake disc:

- Position the brake disc with integrated wheel bearing centrally on the axle journal and slide on
- Screw on hub nut and tighten to specified tightening torque
- Fit hub cap
- Install brake caliper anchor bracket
  - Tighten fixing screws to specified torque
- Push brake piston right back using reset tool
  - At the same time, turn the piston to the right
  - Please note the brake fluid level in the expansion tank
- Insert the piston-side inner brake pad

- When doing so, make sure that all three brackets of the retaining spring are inserted into the piston groove
  
- Fit external brake pad
- Position and mount brake caliper
- Screw in guide bolt and tighten to specified torque
  - Clean the sliding surfaces of the bolts and apply a thin coat of silicone-based grease
- Place dust covers onto the damping sleeves
- Insert brake caliper retaining spring
  
- Check clamping force of retaining spring and replace if necessary
  
- Hook in hand-brake cables
  - Ensure that the cables are correctly positioned and engaged
  
- Depress the brake pedal several times to move the brake pads to the required working position
- Check the brake fluid level in the expansion tank and fill up to the "MAX" mark if necessary
  - Replace brake fluid if necessary
  
- Actuate parking brake several times (pull up, release)
- When the parking brake is released and the lever is pulled up again, there must be play or a clearance of 1 to 2 mm at the end of the cable by the brake caliper.
  
- Carry out final check with diagnostic unit
  - Read out fault memory and clear if necessary
  
- Before mounting the wheel, clean the contact faces of the rims
  
- Carry out a functional check on the test stand and take a test drive
  - Run in brake discs and brake pads
  - Comply with the run-in instructions from the brake pad and vehicle manufacturers













## **Additional vehicle information**

Example vehicle: Renault Espace IV: Electric parking brake with control element and cables.

Tightening torque at the wheel brake for the rear axle

- Screw on brake anchor plate (105 Nm)
- Brake caliper guide bolt (28 Nm)
- Wheel bolt (130 Nm)
- Fastening nut on wheel hub (280 Nm)

## **Maintenance information**

### **The following instructions must be observed:**

Repair work on brake systems may only be carried out by trained specialists.

When carrying out any repairs on the brake system, you must follow the maintenance and safety instructions provided by the vehicle manufacturer and the product-specific assembly instructions.

## **Important safety note**

Technical information and practical tips have been compiled by HELLA in order to provide professional support to vehicle workshops in their day-to-day work. The information provided on this website is intended for use by suitably qualified personnel only.

Reprinting, distribution, reproduction, exploitation in any form or disclosure of the contents of this document, even in part, is prohibited without our express, written approval and indication of the source. The schematic illustrations, pictures and descriptions serve only for the purposes of explanation and representation of the instructions and cannot be used as a basis for installation or assembly work. All rights reserved.