

# Modular LED lamp | HELLA

## General notes

The 55 mm lamp series (tail lamp, stop lamp, rear fog lamp, reverse lamp and direction indicator) has been successfully established on the market for years. Following new requirements as regards function and design, this lamp series is now also available in LED technology. Existing bulb versions and also combinations with LED ring modules can easily be converted to LED variants.

By combining efficient light emitting diodes (LEDs) and precision optics, HELLA rear lamps meet the statutory requirement for light distribution – and indeed with 67% less power consumption when compared with bulbs!

So as to extend the service life of a lamp, all components are matched in such a way that they are optimised to suit temperature conditions. Depending on the model, the housing of the lamp is made of aluminium or plastic. This means that overloading of the LEDs at extremely high ambient temperatures is prevented. Thanks to the use of quality LEDs and good thermal management, these products are designed to last the lifetime of a vehicle, thus making them a convincing, economical and environmentally friendly "fit and forget" solution.





## Product features

- Sealed so as to withstand high-pressure jet cleaning: tested in accordance with the HELLA standard 67101, IP 6K9K, protected against high-pressure jet cleaning/steamjet cleaning.
- High vibration resistance: the lamps are tested in accordance with the HELLA standard 67101 Class 4.1. The high vibration resistance makes this product ideal for use in heavy construction machinery.
- Long service life: the latest LED technology provides an optimum signal pattern with low power consumption.
- Polarity reversal protection: if the contact to the pole is accidentally reversed, the lamp does not suffer any damage.

## Technical drawing

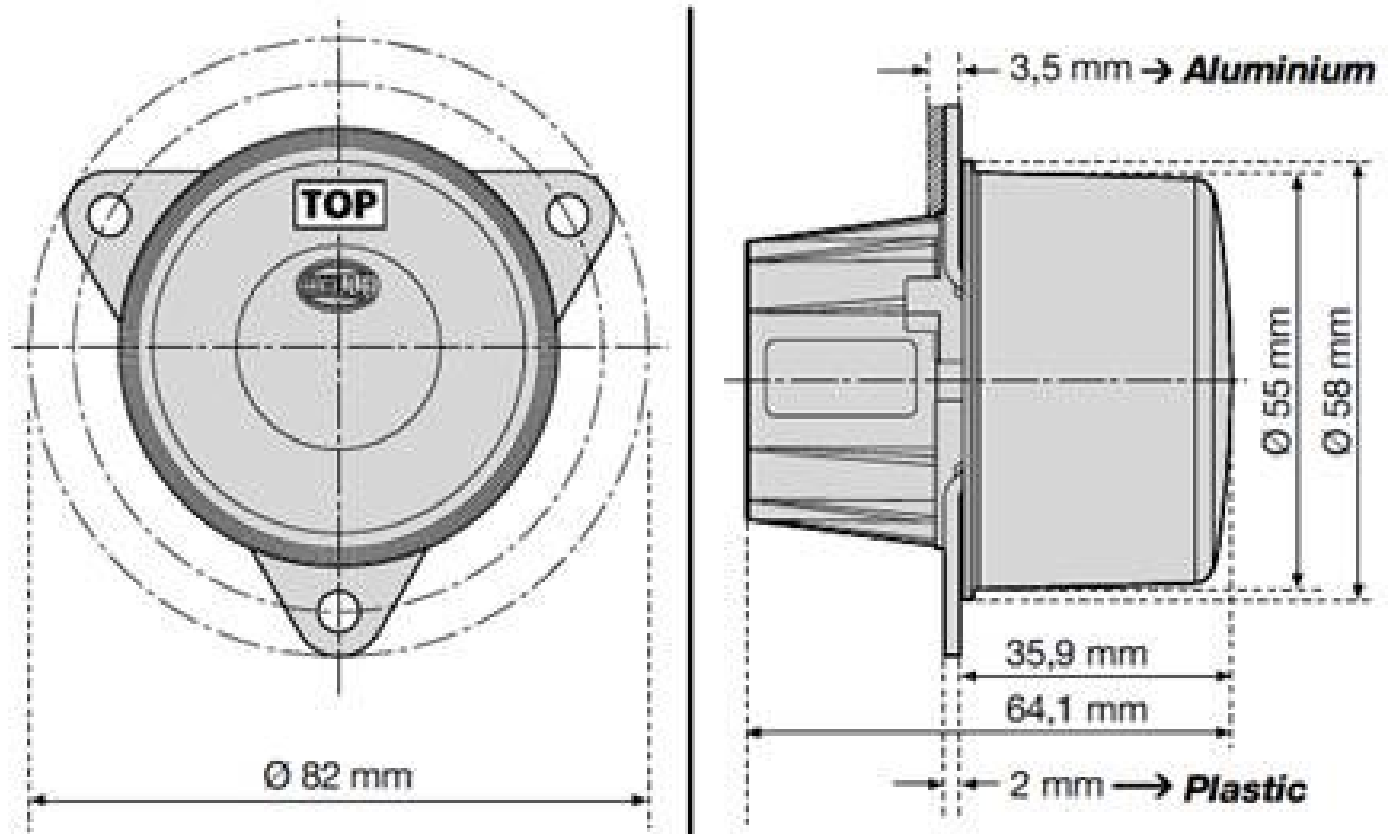

## Special features

The direction indicator function is monitored by electronics built into the lamp. It produces a current pulse for the direction indicator input, which is generated at a defined time. With each flashing pulse, the upstream flasher unit in the vehicle electrical system requires a pulse lasting 20 ms. The pulse request occurs every 100 ms.

If components or LEDs of the direction indicator function are defective, this is recognised by the electronics: the impulse fails to materialise. This means that the driver is always informed of the direction indicator failure. This serves the legally required direction indicator failure detection (in accordance with ECE regulation). Depending on the application, the following ballasts can be used: 5DS 009 552-001/-011.

## Program overview

Part number	Voltage	Function	Flush mounting
2BA 011 172-001/-0072BA 011 172-401/-407With heat sink	12V24V	Direction indicator light	Front
2BA 011 172-011/-0172BA 011	12V24V	Direction indicator light with pulse for	Front

172-411/-417With heat sink		the direction indicator failure control	
2BA 011 172-021/-0272BA 011 172-421/-427	12V24V	Direction indicator light	Rear
2SA 011 172-041/-0472SA 011 172-441/-447	12V24V	Tail light	Rear
2DA 011 172-061/-0672DA 011 172-461/-467	12V24V	Stop light	Rear
2NE 011 172-081/-0872NE 011 172-481/-487With heat sink	12V24V	Rear fog light	Rear
2ZR 011 172-101/-1072ZR 011 172-501/-507With heat sink	12V24V	Reverse light	Rear