

Intake manifold pressure sensor with integrated intake air temperature sensor | HELLA

General

The intake manifold pressure sensor measures the intake manifold vacuum that exists in the intake manifold after the throttle. The measured values of the intake manifold pressure sensor and the intake air temperature sensor are required to calculate the intake air mass.

Depending on the injection system, the intake manifold pressure sensor and the intake air temperature sensor may be installed together as one unit. The intake manifold pressure sensor may be installed directly into the intake manifold or attached in the vicinity.



Structure and function

The sensitive part of the pressure sensor is a Wheatstone bridge in screen printing on a membrane. It is constructed from four resistors which are connected together to form a closed ring, with a voltage source in one diagonal and a voltage test device in the other. On one side of the membrane there is atmospheric vacuum, on the other side the vacuum from the intake pipe. The signal generated by the deformation of the membrane is conditioned by an evaluation electronic circuit and sent to the engine control unit. At rest, the membrane bends according to the outer air pressure. With the engine running, the negative pressure acts on the sensor membrane, influencing the resistance. Since the reference voltage is absolutely constant (5V), the output voltage changes in proportion to the resistance change. The sensor for air temperature is an NTC thermistor (negative temperature coefficient). The sensor resistance becomes smaller as the temperature rises. The input circuit of the electronics distributes the 5 V reference voltage between the sensor resistor and a fixed resistor, so that a voltage is obtained that is proportional to the resistance and hence to the temperature.

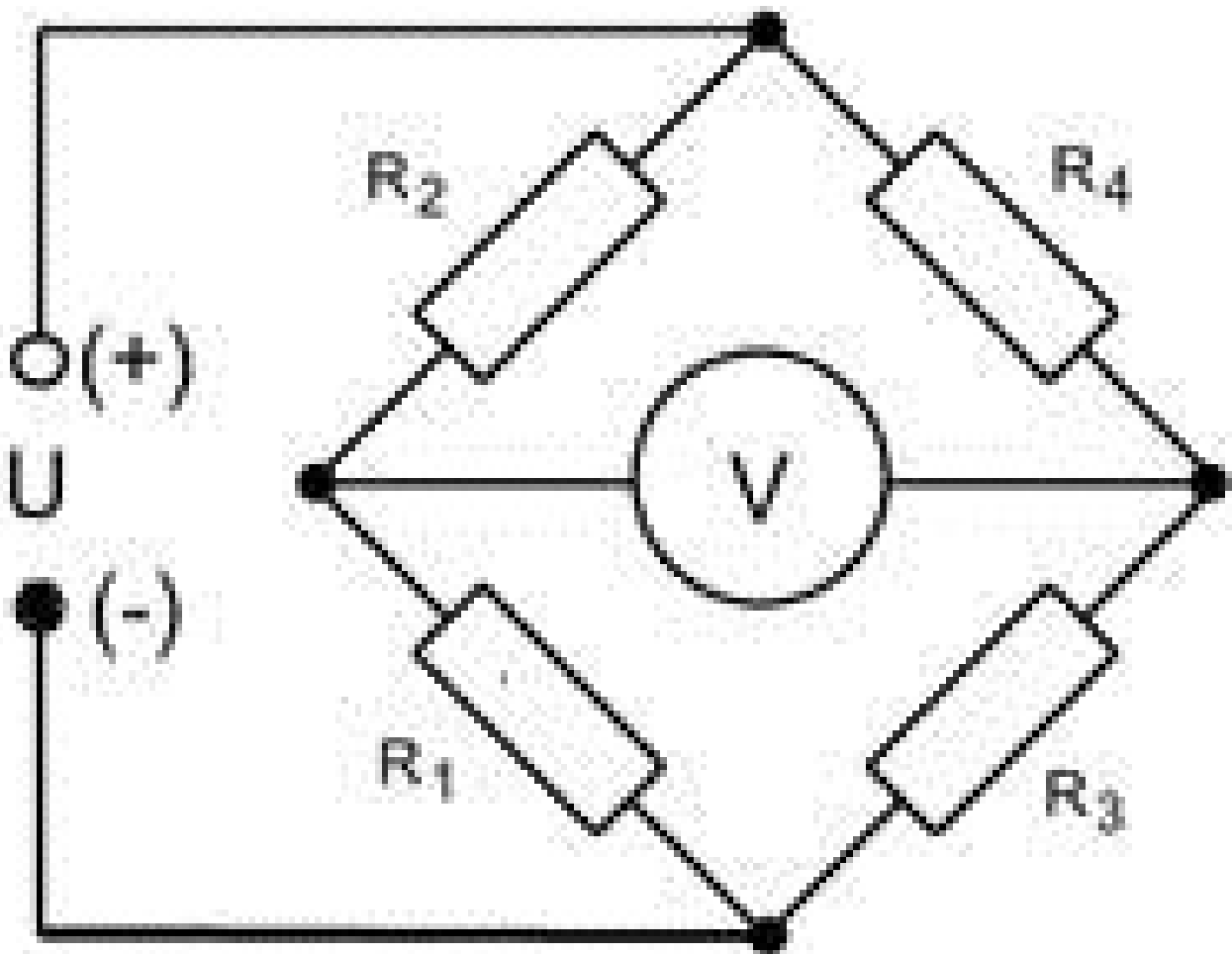

Wiring diagram

Although initially there appears to be no difference from the conventional intake manifold pressure sensor, a closer look at the connector reveals an additional contact in the housing. In the intake

manifold pressure sensor 6PP 009 400-481 depicted in the illustration here, this contact is identified as (t). The NTC installed in the sensor, which is used for monitoring the temperature, is connected with the engine control unit via the cable harness.

Wiring diagram

- (+) Voltage supply
- (-) Ground
- (t) Output / temperature sensor
- (MAP) Output / pressure sensor signal

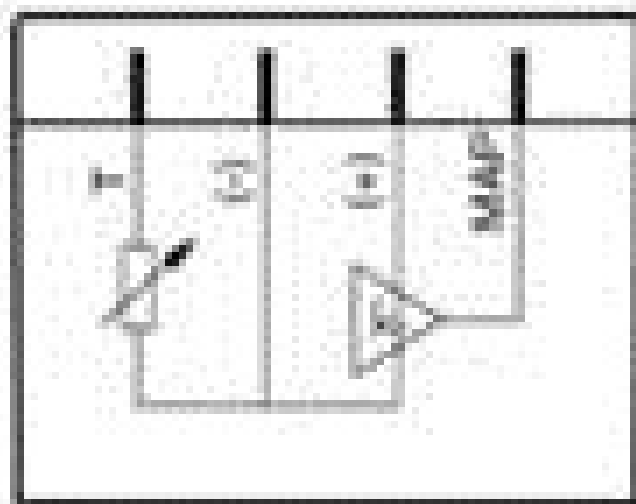
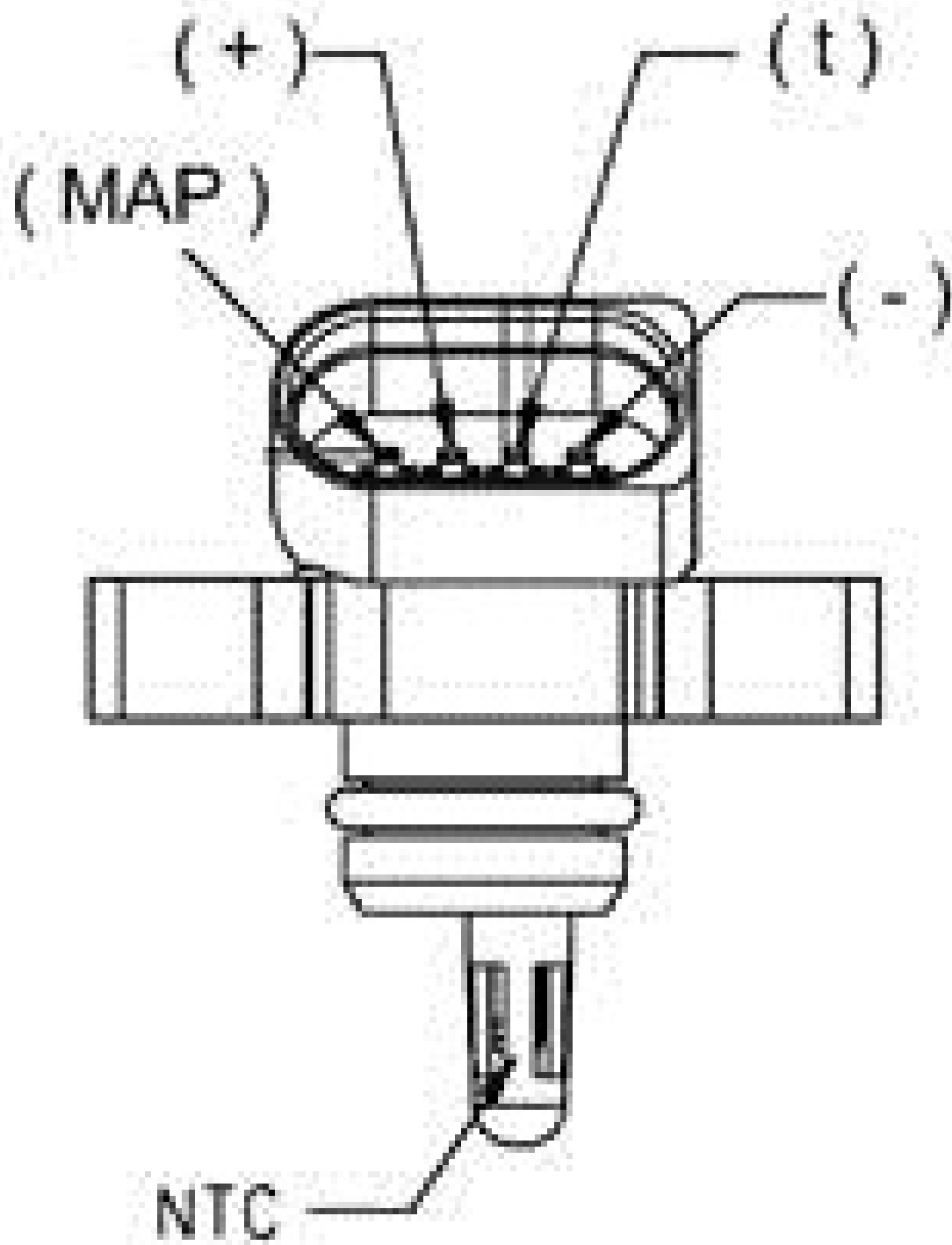

For more information on troubleshooting or causes of failure, see the Technical Information "Intake Manifold Pressure Sensor" (MAP).