

Opel Corsa - Poor engine starting | HELLA

Opel

Opel Corsa-B: Model years 1998 to 2000

Opel Corsa-C: Model year 2001

Poor engine starting,

Poor cold start performance,

Misfire.

If there are complaints for these vehicles that the engine will not start and/or misfires, a possible root cause may be the spark plugs. They should be checked and replaced if necessary. The vehicle manufacturer recommends the spark plug type:

- Spark plug type: FGR 8 KQE0
- Tightening torque 25 Nm
- Electrode gap 1.35 mm

A frequent cause of failure is short-range operation or frequent cold starts.

Fault patterns and possible causes (tightening torque too low):

- Thermal overload of the centre and/or earth electrode and/or the insulator base.
- A broken insulator base.
- A damaged thread.

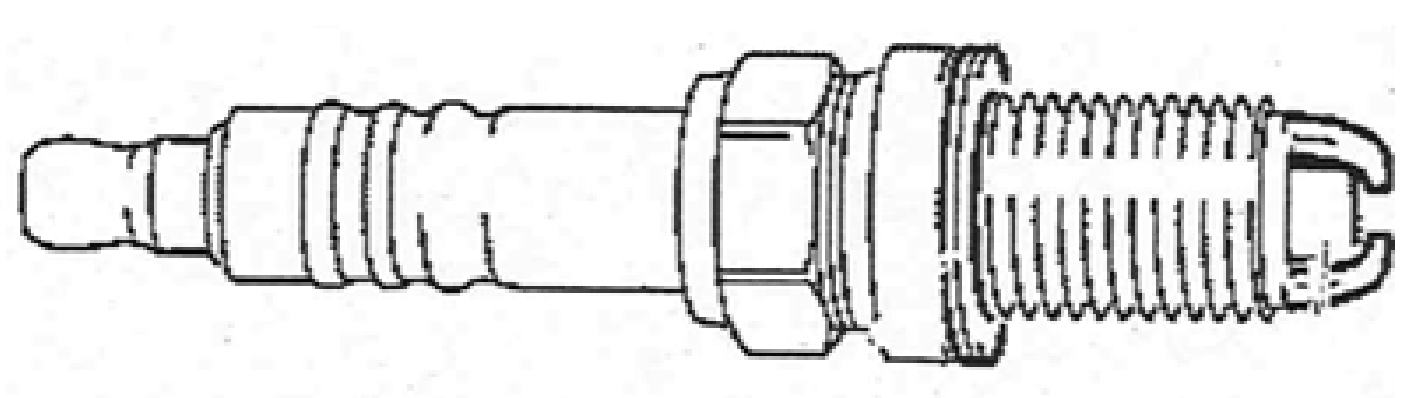

- Thermal overload can be caused by not properly tightened spark plugs. Consequential damages, such as defects in the centre and/or earth electrode and/or the insulator base by loosening or vibration of the spark plugs.

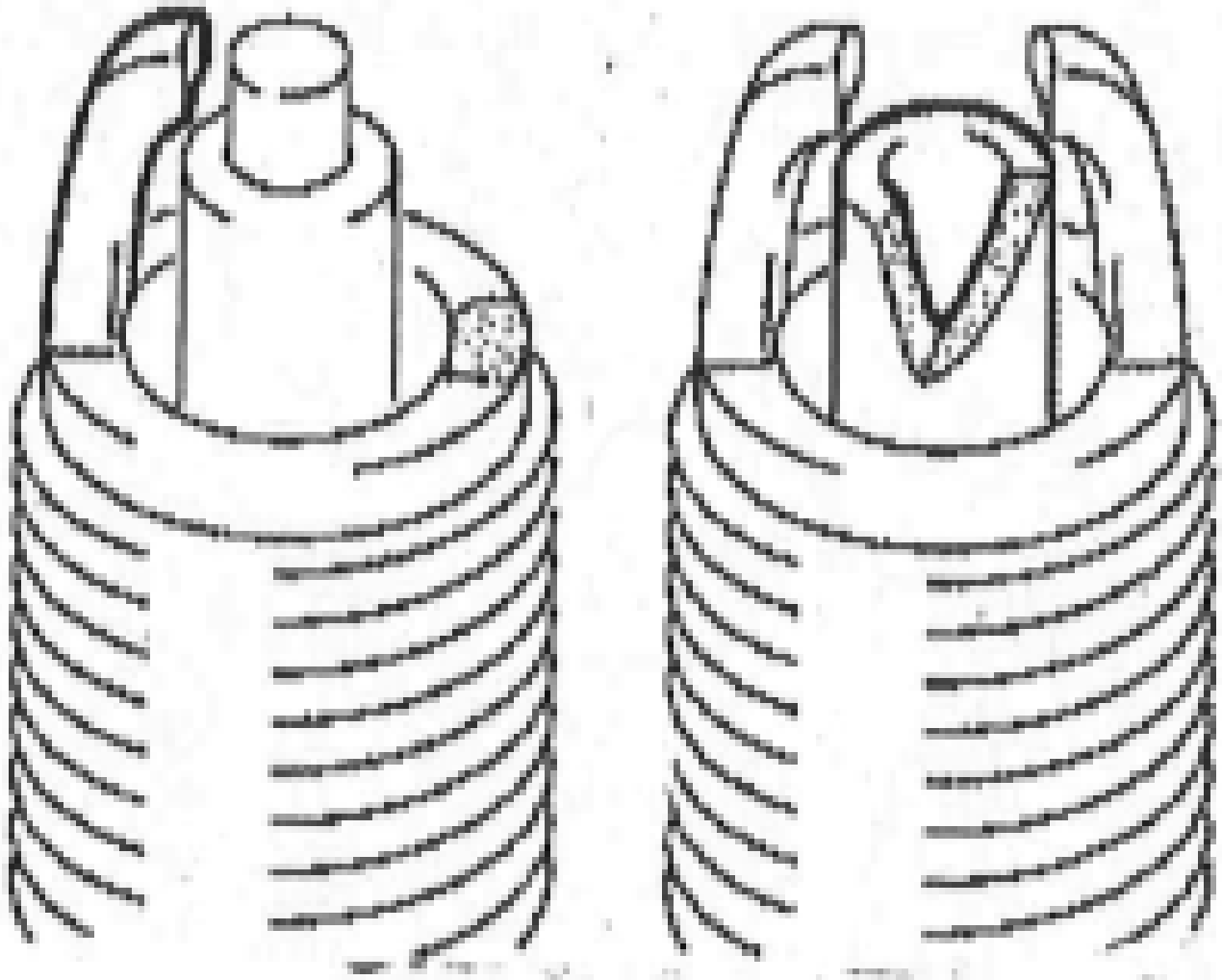

Fault patterns and possible causes (tightening torque too high):

- The spark plug housing/insulator bond has loosened or been damaged. This caused the spark plug to become "leaky".
- Vibration has destroyed the spark plug completely.
- Excessive torque may cause violent rupture of the thread. (Heavy traces of the spark plug wrench may be visible on the hexagon.)

Note:

Consequential damages such as on the engine or cylinder head will not be accepted by the vehicle manufacturers due to various spark damages.