

Mazda 3 - Cooling capacity diminishes while driving | HELLA

Mazda

Mazda 3

From model year 2006 onwards

Cooling capacity diminishes while driving

In the course of a longer journey made in one of the above-mentioned vehicles (with the air-conditioning running at full speed), it is possible that the cooling capacity of the air-conditioning system begins to diminish. A reason for this can be the freezing of the evaporator.

Another sign indicating this problem is the presence of a layer of ice forming on the low pressure line.

Possible causes of this trouble are faulty temperature sensors on the evaporator and also an uneven distribution of air flowing through the evaporator.

This problem can be solved by renewing a sensor that has to be correctly adjusted (including its resistance) and by replacing the interior filter to achieve improved air distribution.

- BP8P-61-J6X Filter set with diffusion plate

- BPY-61545A Wiring harness with resistance

In these cases the following adjustments are recommended by the vehicle manufacturer.

- Make a note of the radio code
- Disconnect the negative poles of the battery and wait at least 5 minutes
- Remove the side panel on the passenger side
- Remove the junction box and loosen the metal bracket
- Undo the plug of the temperature sensor on the evaporator and remove the power MOSFET transistor (when automatic air-conditioning is present)
- Remove the cover of the evaporator box

- Now take out the upper and lower filters of the air-conditioning system
- Insert the new filters with the diffusion plate (Fig. 1) and make sure that the arrows on the filter are pointing in the direction of the rear (Fig. 2). Replace the cover on the evaporator box
- Connect the short wiring harness including resistance with the plug. Then connect both with the temperature sensor on the evaporator

- Finally reassemble all the remaining parts that have been removed and run a check to test how the air-conditioning system now works

Figure 1

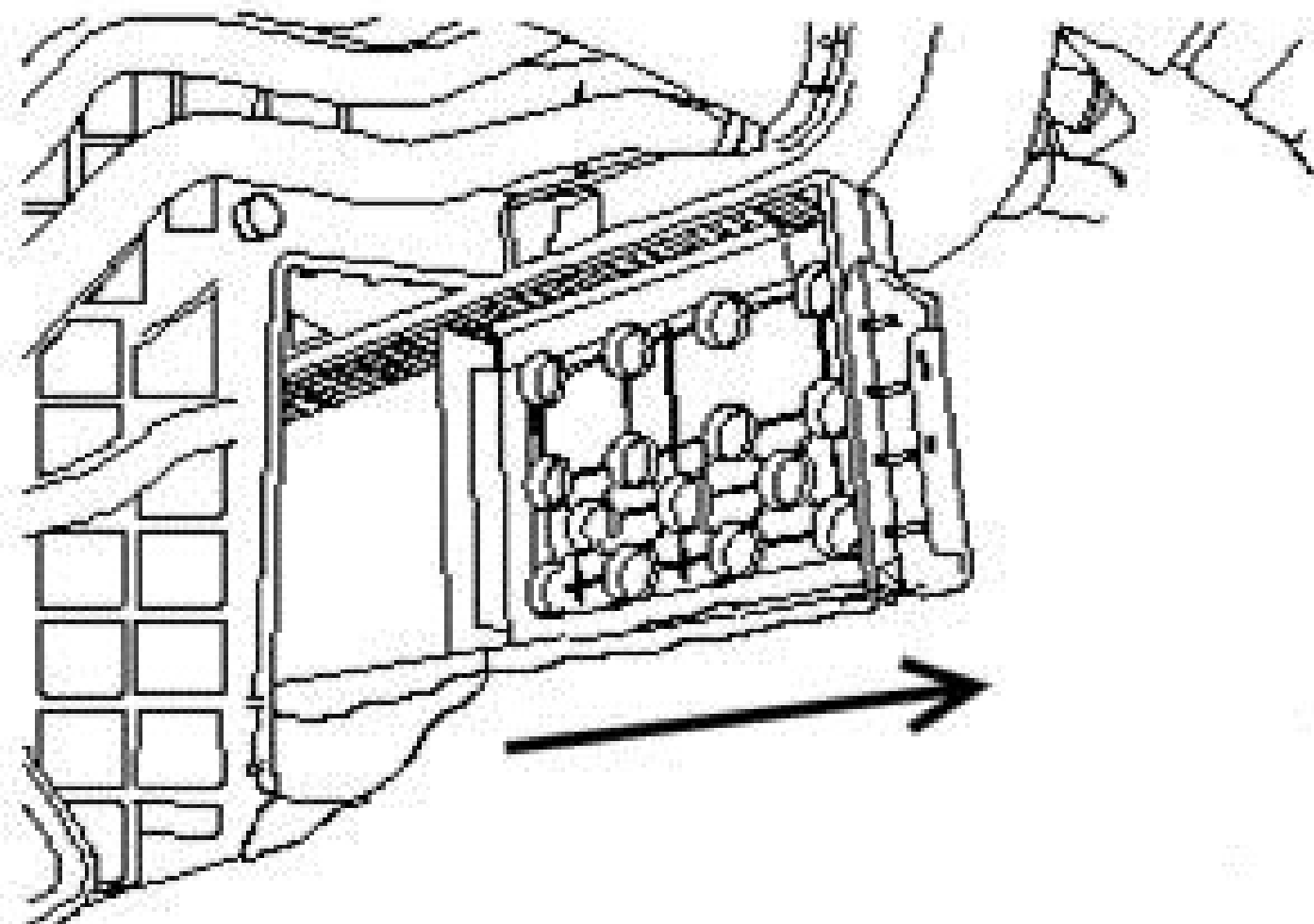

Figure 2

