



Function of the alternator freewheel clutch explained

Data sheet

Spare part

Alternator freewheel clutch

Basic knowledge

Function, structural design and advantages of the alternator freewheel clutch

Important safety note

Technical information and practical tips have been compiled by HELLA in order to provide professional support to vehicle workshops in their day-to-day work. The information provided on this website is intended for use by suitably qualified personnel only.

How does the freewheel of an alternator work?

Overrunning alternator pulleys on alternators

During an engine's combustion cycle, the rotary movement of the crankshaft is sped up and slowed down. This so-called rotational irregularity is transferred to the accessory drive as a result of the alternator's moment of inertia. Consequently, extreme forces and high torque fluctuations act on the belt drive.



Function and structure

The overrunning alternator pulley, also called alternator freewheel clutch, is mounted directly on the drive shaft of the alternator instead of the rigid pulley and has the task of decoupling the three-phase alternator from the rotational irregularities of the crankshaft. This reduces the influence of the moment of inertia on the alternator and the load on the belt drive.

The overrunning alternator pulley is structured as follows

1. Inner ring with serration
2. Outer ring with profiled track
3. Freewheel unit
4. Radial support bearings
5. Overrunning alternator pulley

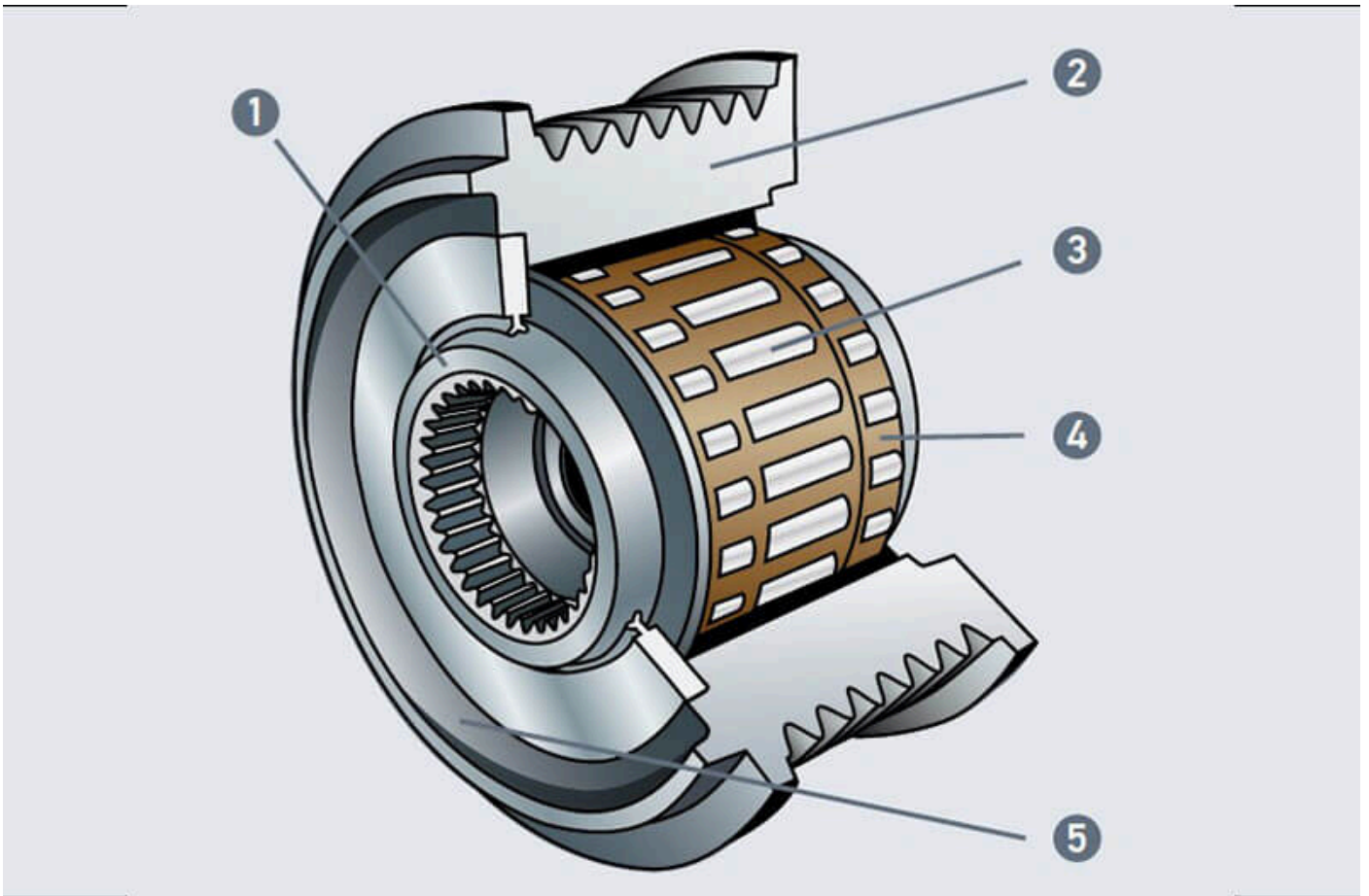

Advantages and effects of an overrunning alternator pulley

Advantages of an overrunning alternator pulley:

- Reduced force level on the belt drive
- Reduced fuel consumption
- Longer service life for all components
- Greater driving comfort and improved noise levels
- Higher alternator idle speed

Effects with and without overrunning alternator pulley:

Accessory drive with rigid pulley (A)

- Severe vibrations and resultant thrashing noise from the drive belt

Accessory drive with alternator freewheel clutch (B)

- Reduction in belt vibrations

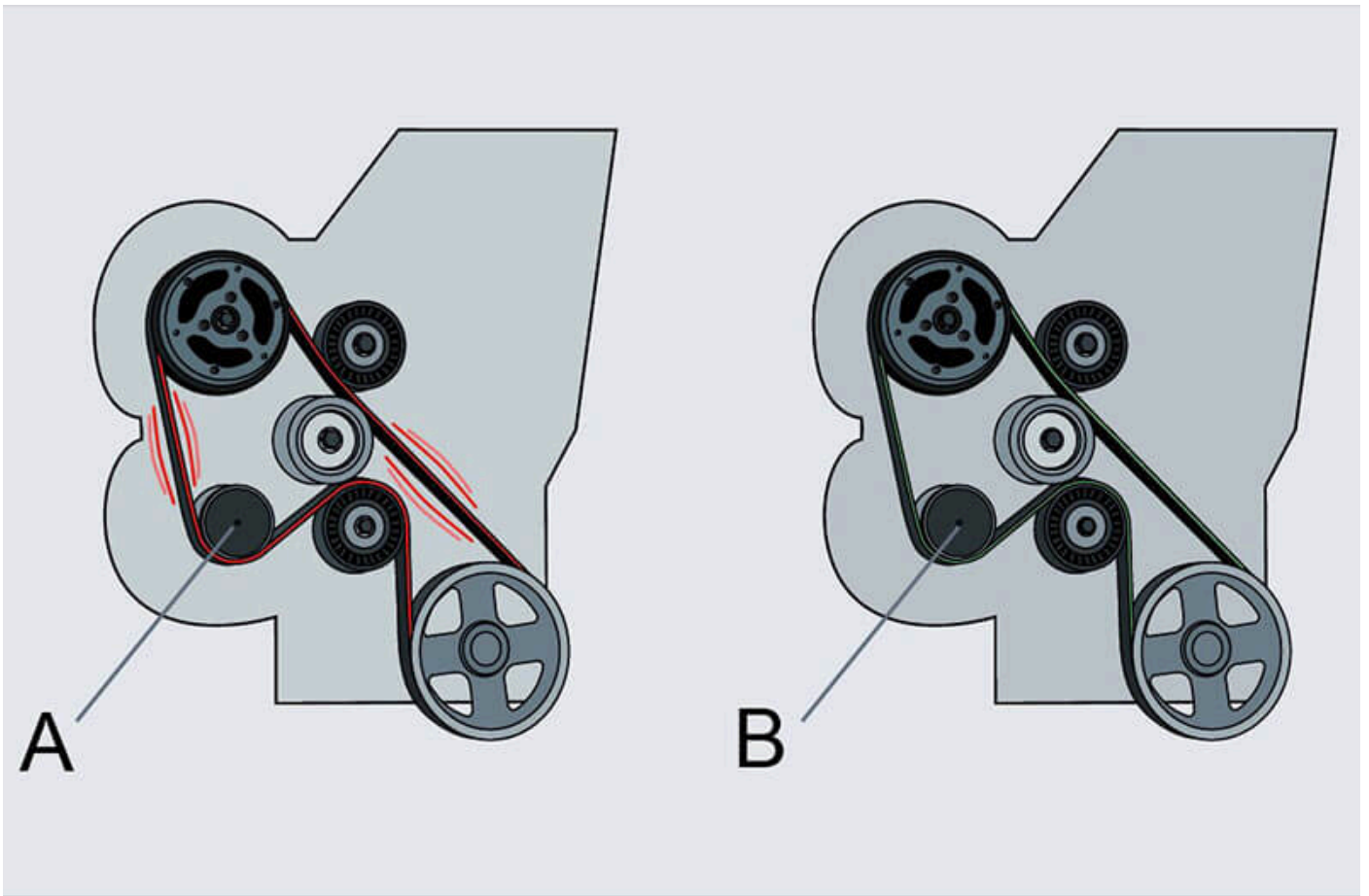

Reprinting, distribution, reproduction, exploitation in any form or disclosure of the contents of this document, even in part, is prohibited without our express, written approval; indication of the document source is also required. The schematic illustrations, pictures and descriptions are provided for explanatory purposes and are only intended as a visual supplement to the document text, so they cannot be used as the basis for installation or assembly work. All rights reserved.