



Changing the alternator freewheel clutch - the procedure

| | |
|-----------------------|--|
| Data sheet | |
| Spare part | Alternator freewheel clutch |
| Part numbers | 9XU 358 038-xxx9XU 358 039-xxx |
| Mounting instructions | Recommended procedure for replacing an alternator freewheel clutch |

Important safety note

Technical information and practical tips have been compiled by HELLA in order to provide professional support to vehicle workshops in their day-to-day work. The information provided on this website is intended for use by suitably qualified personnel only.

Procedure for replacing the alternator freewheel clutch

We recommend the following procedure - overrunning alternator pulleys on the alternator

- Switch off engine
- Remove ignition key
- Remove the V-ribbed belts
- Remove the cover cap on the alternator freewheel clutch
- Fix the overrunning alternator pulley in place
- Insert installation tool
- Rotate installation tool
- Loosen and remove the alternator freewheel clutch
- Mount and tighten the new alternator freewheel clutch (tightening torque 80 +/- 5 Nm)
- Fit cover cap and V-ribbed belts
- Perform functional check

Installation instructions!

Please observe the removal and installation instructions issued by each individual vehicle manufacturer.

- Installation may only be carried out by a qualified specialist
- Note tightening torque
- Do not use pneumatic tools

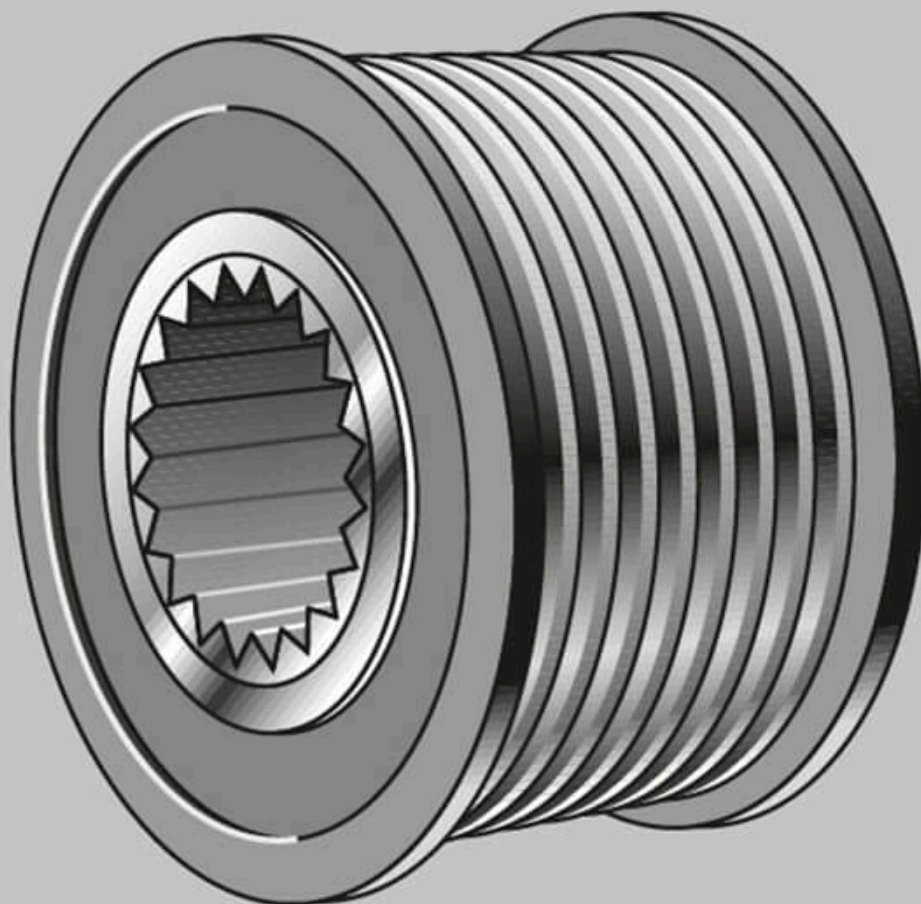

<p>Freilaufriemenscheibe am Generator</p>

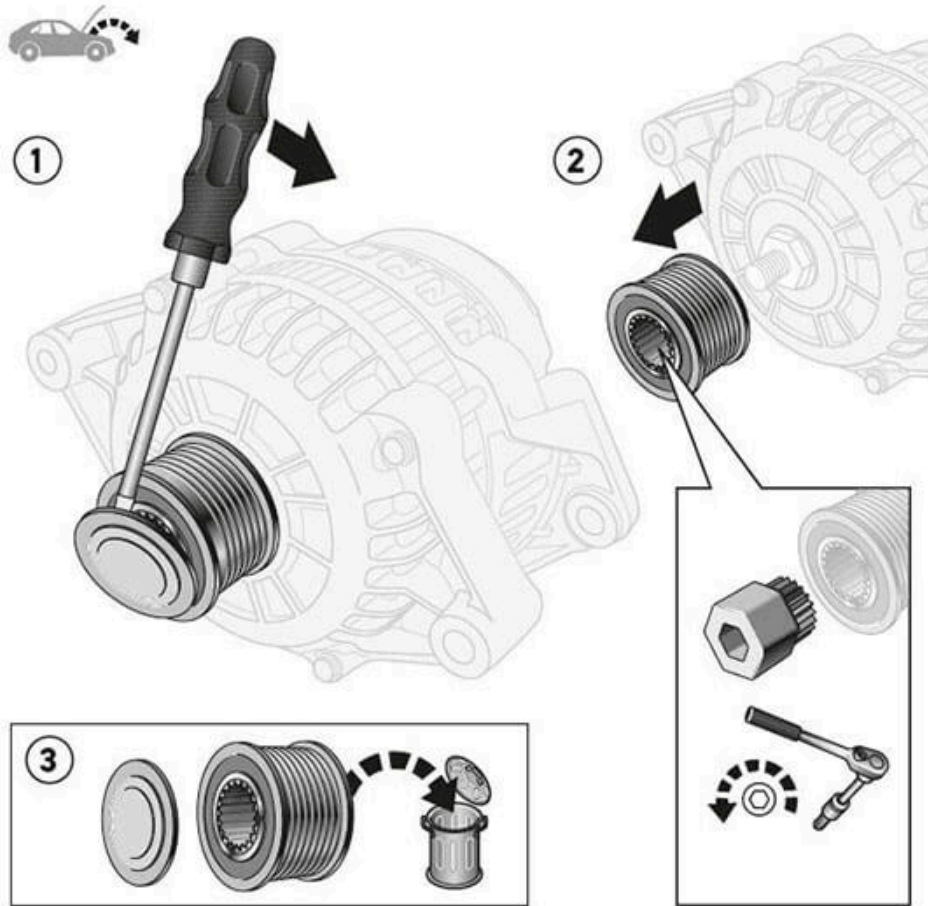

<p>Montagehinweis Freilaufriemenscheibe-Generator bildliche Darstellung 1</p>

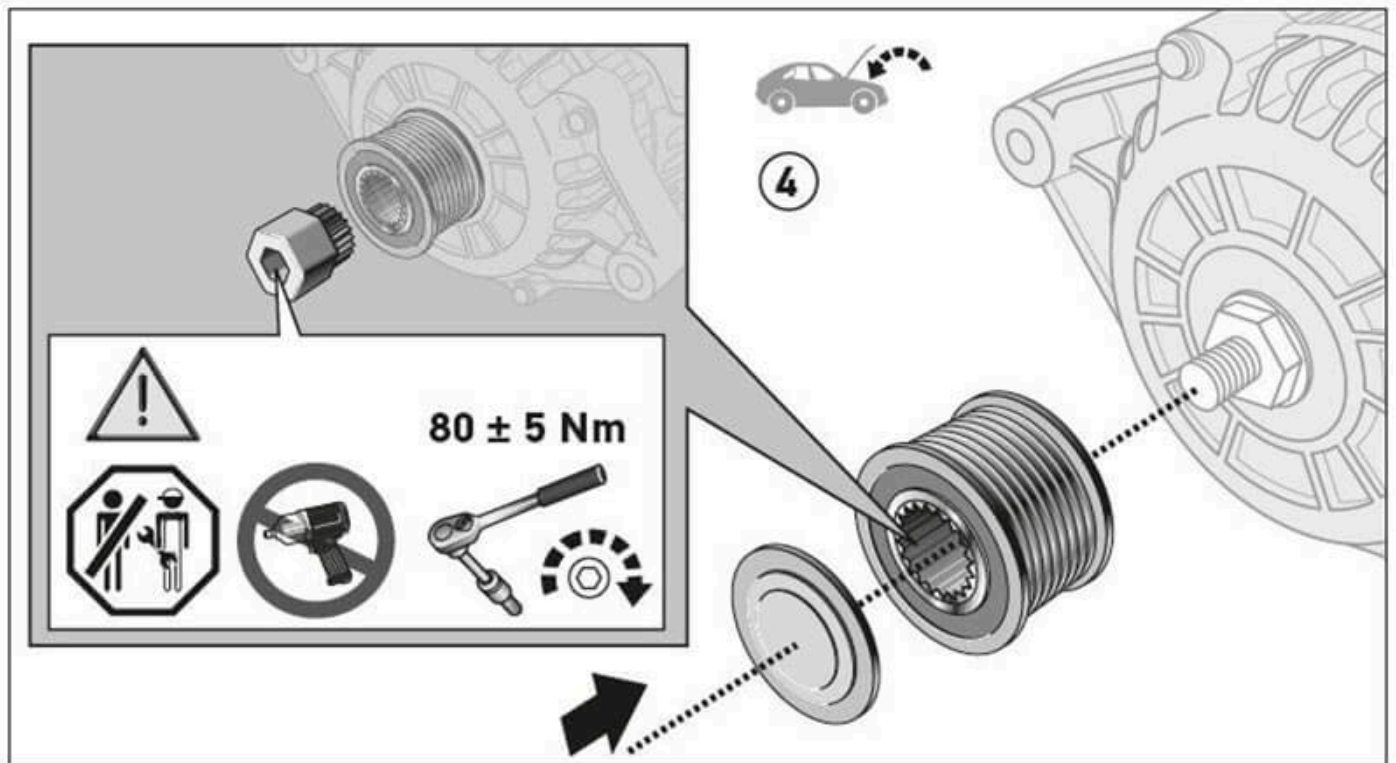

Reprinting, distribution, reproduction, exploitation in any form or disclosure of the contents of this document, even in part, is prohibited without our express, written approval; indication of the document source is also required. The schematic illustrations, pictures and descriptions are provided for explanatory purposes and are only intended as a visual supplement to the document text, so they cannot be used as the basis for installation or assembly work. All rights reserved.