

Since **September 1, 2021** an **underride guard** according to **UNECE R58-03** is **mandatory** for all newly homologated trucks (N2 and N3 > 3.5 t) and trailers (O3 and O4 > 3.5 t)!

BRIEF INFORMATION

FORVIA HELLA underride guard

- › Robust aluminium underride guard according to UNECE R58-03 for trucks (N2 and N3 > 3.5 t) and trailers (O3 and O4 > 3.5 t) for high degree of road safety
- › Can be used for several track widths thanks to flexible mounting position
- › Various hole patterns ensure maximum modular freedom
- › Suitable for a wide range of customer applications

PRODUCT FEATURES

Trucks are becoming even safer: Higher requirements for underride protection

The following can be fatal: When smaller vehicles such as cars or bicycles slide under the truck, particularly serious injuries often occur. The underride guard stops vehicles before they literally come under the wheels, thus preventing the most serious consequences of accidents in many cases.

Rear-end collisions are a particularly high risk. To ensure that the rear underride protection unit also withstands the impact of heavy cars, the requirements for the component were adapted. Compared to before, the test forces stipulated in the new UNECE R58-03 have been almost doubled!

The new underride protection from FORVIA HELLA easily meets these new requirements. The component is made of durable aluminium and is available with two different brackets so that it can be fitted to vehicles with different chassis heights.

On request, the underride guard can also be equipped with customisable hole pattern, painted in various RAL colours and fitted with a rubber spray flap. The product thus offers the right solution for every customer.

COMPARISON BETWEEN ECE-R58 REVISION 02 AND 03 (NEW)

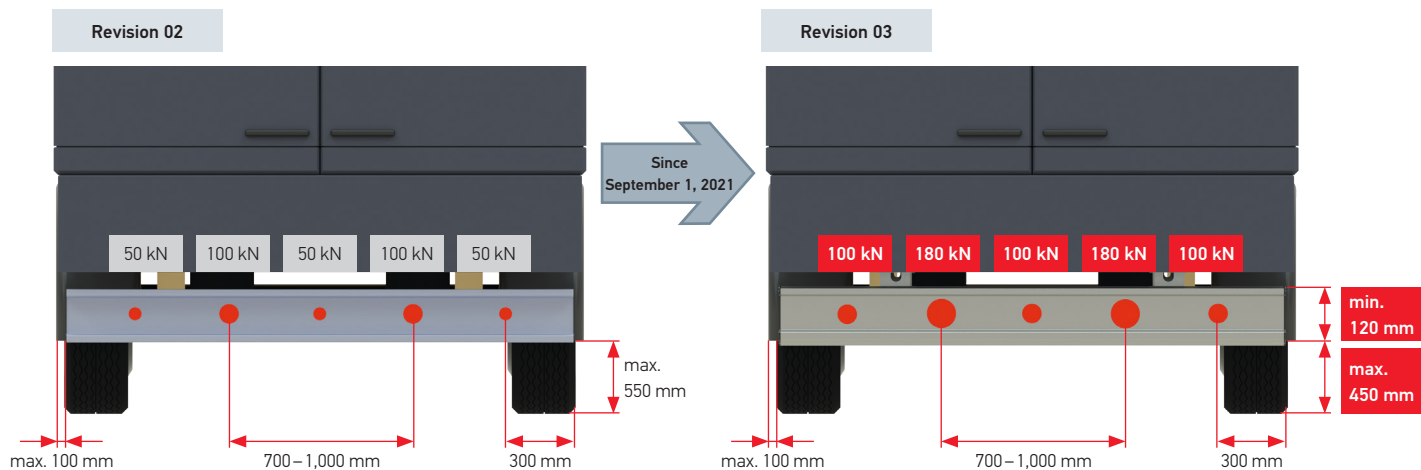

● Application of the test force

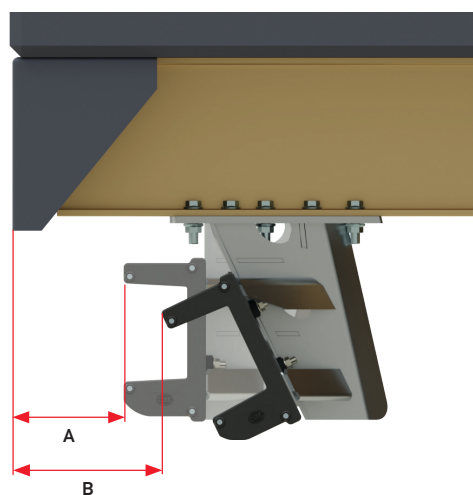

Vehicle classes 03 & 04	A	B
	Maximum distance from the rear	Maximum distance from the rear, including any occurring deformations or distortions
Revision 02	max. 400	max. 500
Revision 03	max. 200	max. 300

FORVIA HELLA UNDERRIDE GUARD COMPONENTS

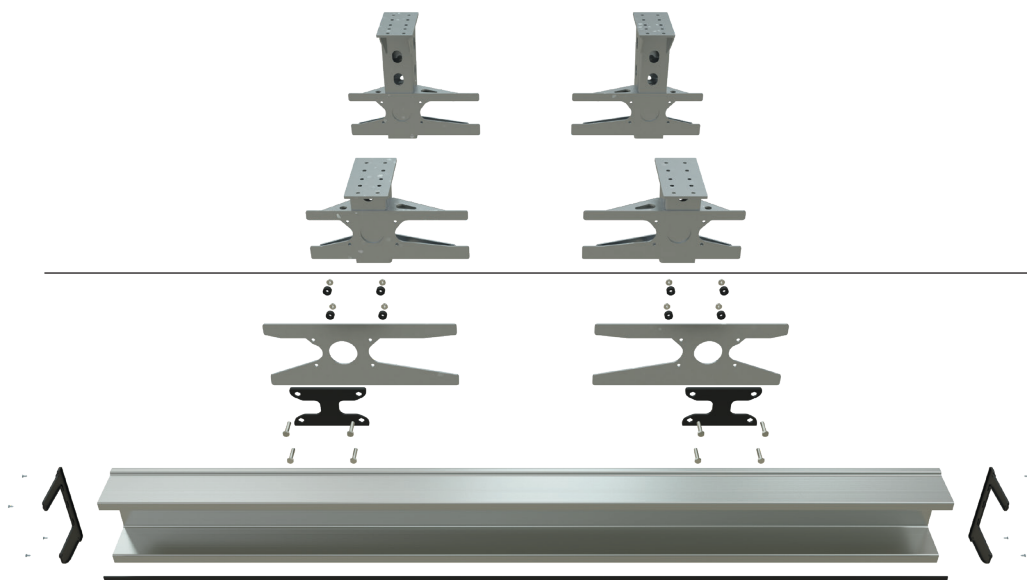

Necessary accessories

- 1x bracket left, tall
- 1x bracket right, tall
- 1x bracket left, short
- 1x bracket right, short

Scope of delivery

- 1x underbody guard
- 1x side cover left
- 1x side cover right
- 1x mounting plate left
- 1x mounting plate right
- 1x plastic cover for cable duct

TECHNICAL DETAILS

Dimensional sketch

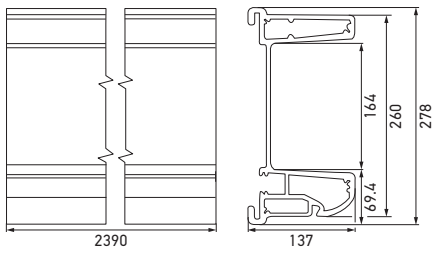

Underride guard

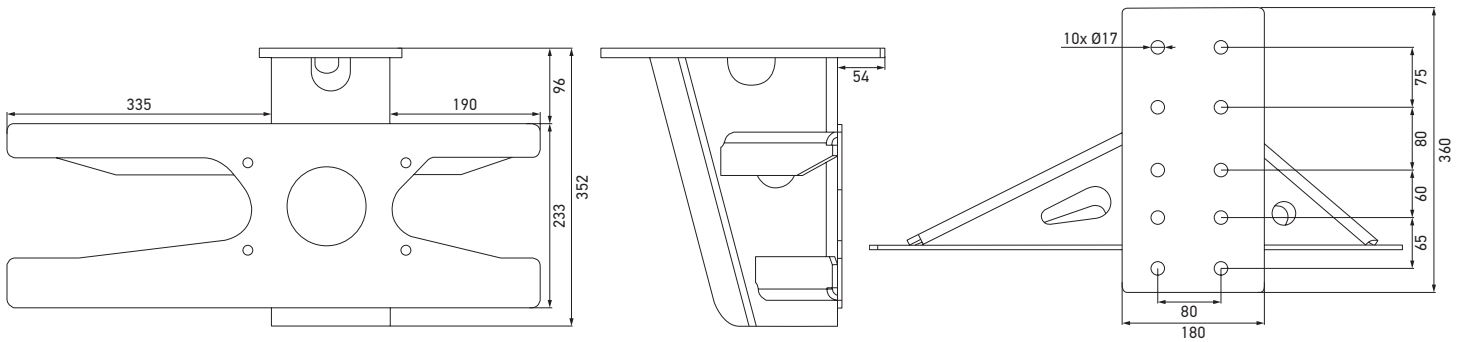

Short bracket

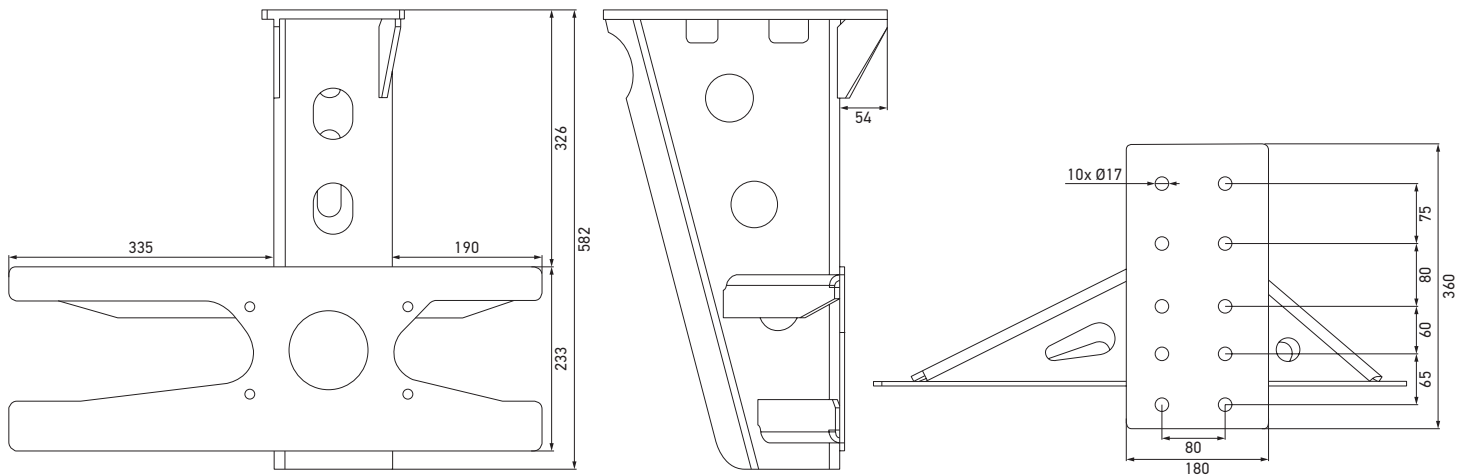

Tall bracket

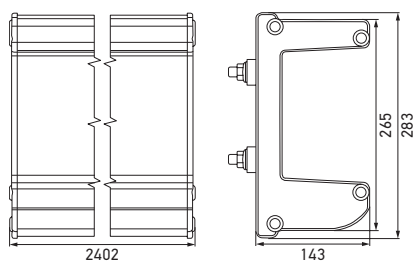

Underride guard including side covers

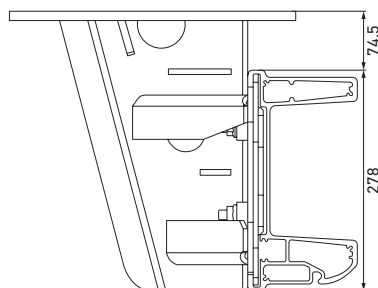

Underride guard with short bracket

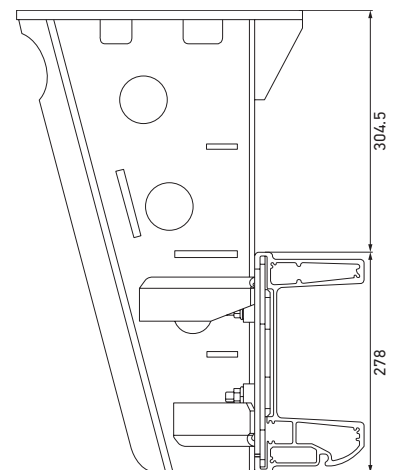

Underride guard with tall bracket

MOUNTING



Bring together the fastening plate and the underride guard using the guide rail.



Mount the rear lamp on the underride guard using the hole patterns suitably milled.



Attach the side cover to the underride guard.

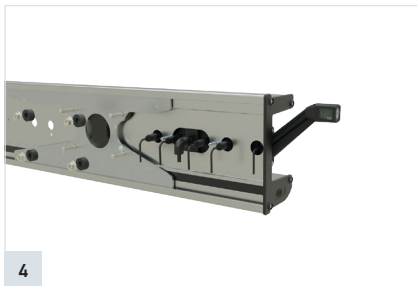

Loosen the fastening screws of the fastening plate to install the underride guard on the vehicle.



Attach the brackets to the vehicle.

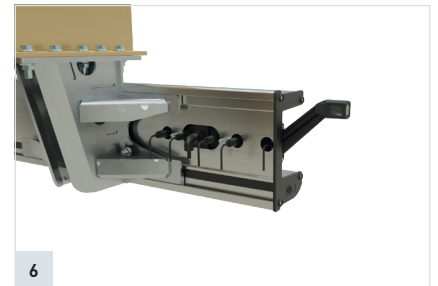

Mount the underride guard on the vehicle using brackets.

FLEXIBLE TRACK WIDTH

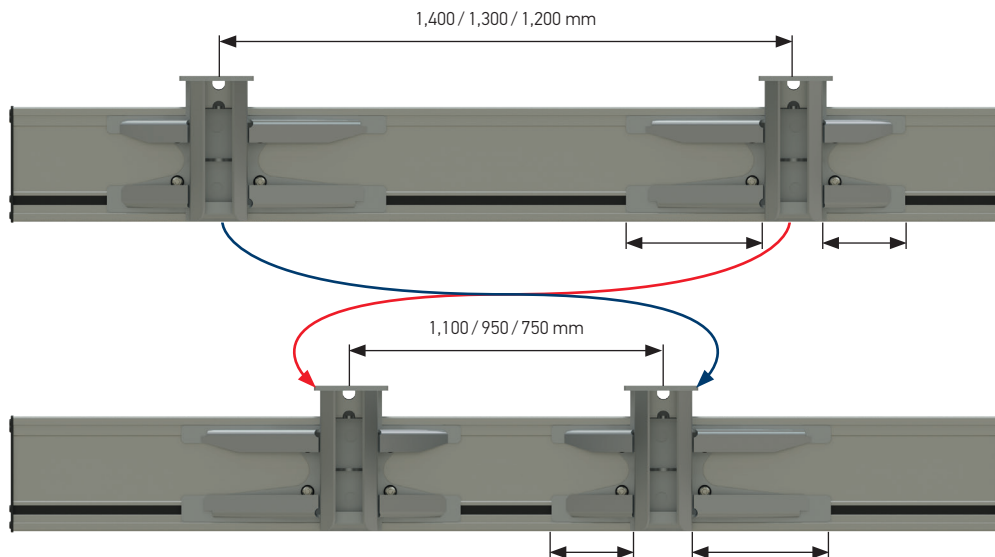

The fastening brackets can be moved and interchanged so that a minimum track width of 750 mm can be achieved.

PROGRAM OVERVIEW

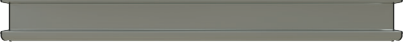
Hole pattern	Track width	Part number
	750 mm – 1,400 mm (scope of delivery see page 2 below)	9XX 340 384-001

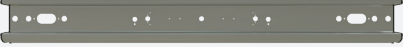
Hole pattern	Track width	Part number
	1,100 mm – 1,400 mm	9XX 340 384-011

Mounting examples

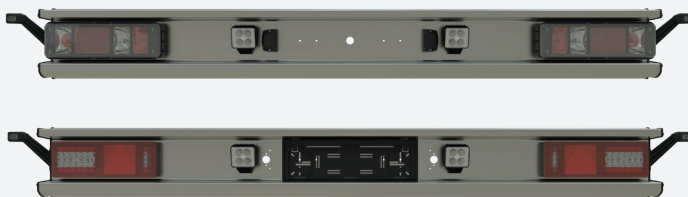

Hybrid and full LED rear lamp DIN / SS and EC	2VP 340 96...-...
Full LED rear lamp DIN / SS	2VP 340 970...-...
Cover dome	8XS 340 092...-...
LED licence plate holder	2KA 329 280...-...
LED licence plate lamp	2KA 012 271...-...
LED reverse lamp ECO18 LED	2ZR 996 479...-...
Rear adapter	8KA 340 819...-...

Hole pattern	Track width	Part number
	1,200 mm – 1,400 mm	9XX 340 384-021

Mounting examples



Hybrid and full LED rear lamp SBBL DIN	2SD 013 155...-...
Full LED rear lamp NESZR DIN	2NR 013 155...-...
Triangular reflex reflector	8RA 002 020...-...
LED licence plate holder	2KA 329 280...-...
LED licence plate lamp	2KA 012 271...-...
Rear adapter	8KA 340 819...-...

Hole pattern	Track width	Part number
	950 mm – 1,400 mm	9XX 340 384-031

Mounting examples



Hybrid and full LED rear lamp SBBL DIN	2SD 013 155...-...
Triangular reflex reflector	8RA 002 020...-...
LED licence plate module with rear fog light	2NE 340 980...-...
LED reverse lamp ECO18 LED	2ZR 996 479...-...
Rear adapter	8KA 340 819...-...

NECESSARY ACCESSORIES

To comply with the new legal regulation UNECE R58-03, it is mandatory to have brackets to secure the underride guard to a vehicle. You have the option of choosing between tall and short brackets.

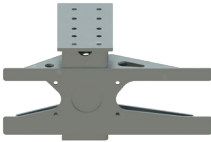
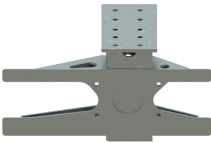
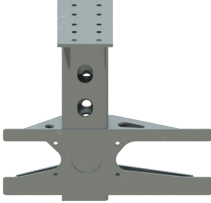
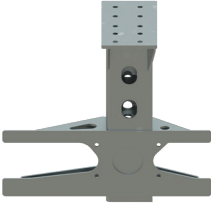
Product image	Description	Part number
	Bracket left, short (352 mm)	9XX 340 383-011
	Bracket right, short (352 mm)	9XX 340 383-021
	Bracket left, tall (582 mm)	9XX 340 383-031
	Bracket right, tall (582 mm)	9XX 340 383-041

COLOURS

Standard version:

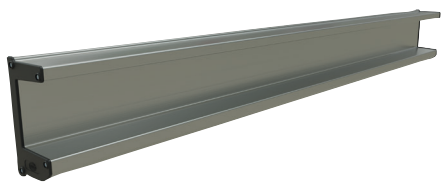

Raw aluminium



PP-TPE Black

On request:

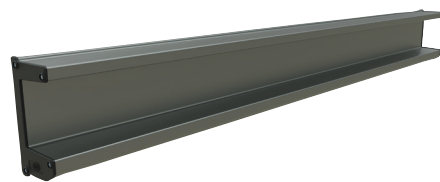

Anodised aluminium

Further powder coatings in various RAL colours for underride guard and side cover available on request.

