



You'd like more information?  
Please scan the QR code or  
click on it straight away.

# BRIEF INFORMATION

## CA4X series Compressed Air Horns

- Wide and far reaching sound
- Chromed finished trumpet
- With flat connections of 6.3 mm, open, blade type
- Horn set includes separate air compressor
- Retrofit kits for warning sound update

### PRODUCT FEATURES

#### Application

Horns are a mandatory part of the safety equipment of a vehicle. A particularly perceptible sound is necessary in order to be able to warn other road users optimally in dangerous situations. Our signal horns offer you a high level of functional reliability.

#### Design and function

- The sound is generated in the spiral horn by the vibration of two metal diaphragms set in vibration by the pressurized air produced by the electric compressor.
- The diaphragms that are positioned inside the acoustic chambers press on the sealing lip which forms the inlet of the acoustic duct.
- When a certain pressure is generated inside the acoustic chambers, the diaphragms move away from the lip resulting in passage of air and pressure drop, and then close again on the lip.
- The cyclic repetition of this phenomenon generates the sound waves.

# TECHNICAL DETAILS

## Technical data

Short Code	CA40	CA42	CA44
Rated voltage	12 V or 24 V	12 V or 24 V	12 V
Frequency range	370 Hz	370 / 415 Hz	350 / 500 Hz
Sound pressure level @ 2 m	≥ 120 dB(A)	≥ 120 dB(A)	≥ 122 dB(A)
Power consumption (horn and compressor)	312 W	360 W	432 W
Compressor included		Yes	
Operating temperature		-40 °C to +75 °C	
Protection class		IP 54	
Service life		50,000 cycles (ECE-R28)	
Housing material		ABS	
Type approval		ECE-R28	

## Dimensional sketches

CA40 Chrome Single Air Horn

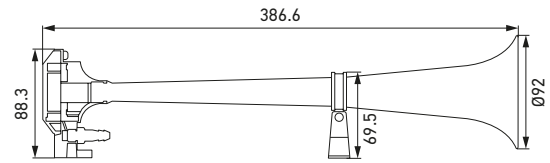

Spare part | CM40 Compressor

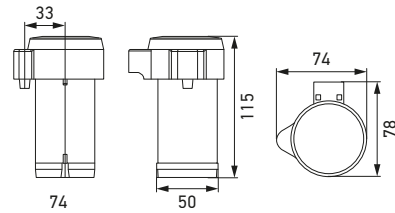

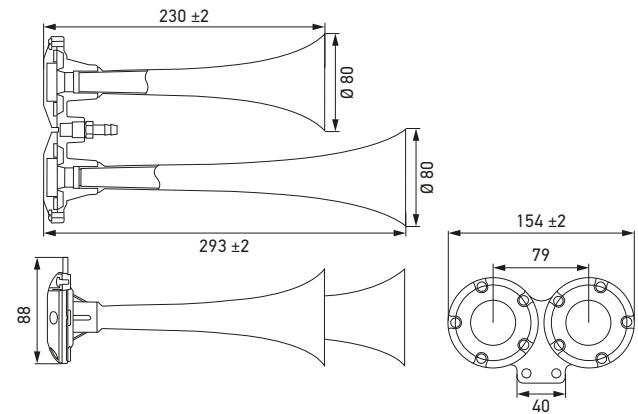

CA42 Chrome Double Air Horn

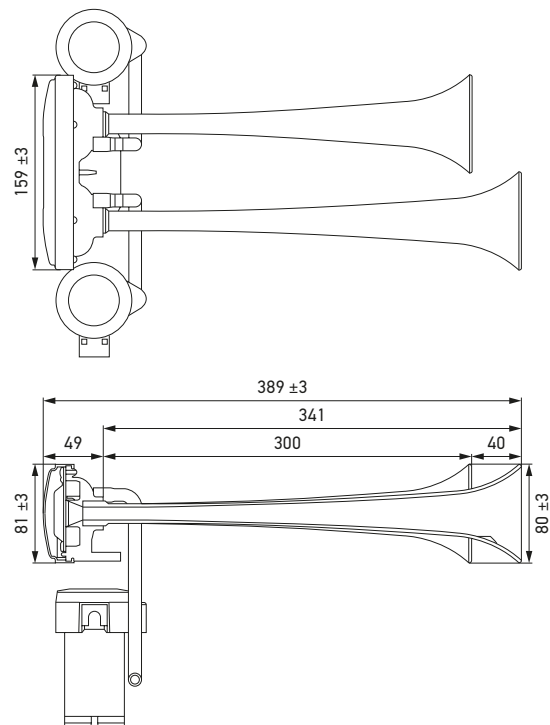

CA44 Chrome Double Air Horn



# PROGRAM OVERVIEW

Product picture	Description	Part number	Packaging unit
<b>CA40 Chrome Single Air Horn</b> Includes: air horn, compressor, pressure tubes, bifurcated piece, fastening and relay			
	12 V, 370 Hz	<b>3PA 013 410-001</b>	1 piece
	24 V, 370 Hz	<b>3PA 013 410-021</b>	1 piece
<b>CA42 Chrome Double Air Horn</b> Includes: air horn, compressor and pressure tubes			
	12 V, 370 / 415 Hz	<b>3PB 013 410-121</b>	1 piece
	24 V, 370 / 415 Hz	<b>3PB 013 410-131</b>	1 piece
<b>CA44 Black coated Double Air Horn</b> Includes: air horn, compressor and pressure tubes			
	12 V, 350 / 500 Hz	<b>3PB 013 410-211</b>	1 piece

## ACCESSORIES

Product picture	Description	Part number	Packaging unit
<b>CM40</b> Replacement spare part for CA40-series			
	12 V	<b>9MN 715 991-051</b>	1 piece
	24 V	<b>9MN 715 991-061</b>	1 piece