

MONTAGEANLEITUNG

K-LED Nano

INSTALLATION INSTRUCTION

K-LED Nano

INSTRUCTIONS DE MONTAGE

K-LED Nano

MONTERINGSANVISNING

K-LED Nano

MONTAGEHANDLEIDING

K-LED Nano

INSTRUCCIONES DE MONTAJE

K-LED Nano

ISTRUZIONI DI MONTAGGIO

K-LED Nano

ASENNUSOHJE

K-LED Nano

DE PRODUKTHAFTUNG

- Es sind die nationalen Anbau-, Einbau- und Betriebsvorschriften zu beachten und einzuhalten.
- Lesen Sie bitte vor Gebrauch des Gerätes alle beigelegten Anleitungen und Sicherheits-hinweise.
- Im Zuge von Produktverbesserung behalten wir uns technische und optische Änderungen vor.
- Verwenden Sie nur die Originalersatzteile bzw. nur Ersatzteile die von HELLA freigegeben sind.
- Bei Fragen oder Einbauproblemen, wenden Sie sich bitte an den HELLA Kundendienst, den Großhändler oder an Ihre Werkstatt.
- Weitere Informationen finden Sie auch auf unserer Internetseite (www.hella.com/techworld)

EN PRODUCT LIABILITY

- National mounting, fitting and operating regulations must be heeded and kept.
- Please read all the instructions and safety notes included before using the device.
- We reserve the right to make technical and optical modifications within the course of product improvement.
- Only use original spare parts or spare parts approved by HELLA.
- If you have any questions or problems with the installation, please contact HELLA Customer Services, a wholesaler or your garage.
- Further information is available on our website (www.hella.com/techworld)

FR RESPONSABILITÉ PRODUIT

- Les prescriptions nationales en matière de montage et de service doivent être observées et respectées.
- Avant d'utiliser l'appareil lire toutes les instructions de montage et de service fournies ainsi que les conseils de sécurité.
- Dans le cadre de l'amélioration continue de nos produits, nous nous réservons le droit de réaliser des modifications sur les plans technique et optique.
- Utilisez uniquement des pièces d'origine ou des pièces de rechange validées par HELLA.
- Pour toute question ou en cas de problèmes de montage, veuillez contacter le S.A.V. ou le distributeur HELLA ou bien vous adresser à votre garagiste.
- Vous trouverez également des informations complémentaires sur notre site Internet (www.hella.com/techworld)

SV

PRODUKTANSVAR

- De nationella monterings-, installations- och driftföreskrifterna ska beaktas och följas.
- Läs alla medföljande instruktioner och säkerhetsanvisningar innan du använder apparaten.
- Vi förbehåller oss rätten till tekniska och optiska ändringar som förbättrar produkten.
- Använd endast original reservdelar resp. endast reservdelar som har godkänts av HELLA.
- Vid frågor eller monteringsproblem, kontakta HELLA kundtjänst, grossisten eller din verkstad.
- Mer information finns också på vår webbplats (www.hella.com/techworld)

NL

PRODUCTAANSPRAKELIJKHEID

- Men dient de nationale aanbouw-, inbouw- en bedrijfsvoorschriften in acht te nemen en na te leven.
- Lees a.u.b. alvorens het apparaat te gebruiken alle bijgevoegde gebruiksaanwijzingen en veiligheidsinstructies door.
- In het kader van de productverbetering behouden wij ons technische en optische veranderingen voor.
- Gebruik uitsluitend de originele reserveonderdelen, die door Hella vrijgegeven zijn.
- Neem bij vragen of inbouwproblemen contact op met de HELLA klantenservice, de groothandel of het garagebedrijf.
- Meer informatie is ook te vinden op onze website (www.hella.com/techworld)

ES

RESPONSABILIDAD CIVIL POR PRODUCTOS DEFECTUOSOS

- Tienen que observarse y cumplirse con las prescripciones nacionales sobre construcciones anexas, de montaje y de funcionamiento.
- Rogamos que antes de usar el aparato lean todas las instrucciones y advertencias sobre la seguridad adjuntas.
- En aras de la mejora de los productos, nos reservamos el derecho de hacer modificaciones técnicas y ópticas.
- Use sólo recambios originales o bien sólo recambios autorizados por HELLA.
- En caso de dudas o preguntas a la hora del montaje, llame al servicio de atención al cliente de HELLA o diríjase a su Distribuidor o Taller.
- Encontrará más información en nuestra página web (www.hella.com/techworld)

IT

RESPONSABILITÀ PER IL PRODOTTO

- Si devono rispettare tutte le normative nazionali di attacco, montaggio e funzionamento.
- Prima di usare l'apparecchio, legga per favore tutte le istruzioni e le avvertenze di sicurezza allegate.
- Nell'ambito del perfezionamento del prodotto, ci riserviamo modifiche tecniche ed estetiche.
- Utilizzare solo pezzi di ricambio originali risp. pezzi autorizzati dalla HELLA.
- Per eventuali domande o problemi di installazione contattare l'Assistenza Clienti HELLA, il grossista o rivolgersi alla propria officina.
- Ulteriori informazioni sono disponibili anche sul nostro sito web (www.hella.com/techworld)

FI

TUOTEVASTUU

- Kansalliset asennus- ja käyttöohjeet on huomioitava ja niitä on noudatettava.
- Lue ennen laitteen käyttöä kaikki oheistetut käyttö- sekä turvaohjeet.
- Jatkuvasta tuotekehittelystä johtuen pidätämme oikeuden teknisiin ja optisiin muutoksiin.
- Käytä vain alkuperäisiä tai HELLA hyväksymiä varaosia.
- Jos sinulla on kysyttävää tai asennusongelmia, käänny HELLA-asiakaspalvelun, tukkuliikkeen tai korjaamon puoleen.
- Lisätietoja löytyy verkkosivustoltamme (www.hella.com/techworld).

DE Technische Änderungen vorbehalten

EN Subject to alteration without notice

FR Sous réserve de modifications techniques

SV Vi reserverar oss för tekniska ändringar

NL Technische wijzigingen voorbehouden

ES Reservadas modificaciones técnicas

IT Con riserva di modifiche tecniche

FI Oikeus teknisiin muutoksiin pidätetään

Zeichenerklärung
Explanation symbols
Explication des symboles

Symbolförklaring
Legenda
Aclaración de símbolos

Legenda
Piirroksen selitys



- (DE) Richtig
 (EN) Correct
 (FR) Correct
 (SV) Rätt
 (NL) Goed
 (ES) Correcto
 (IT) Giusto
 (FI) Oikein



- (DE) Falsch
 (EN) Incorrect
 (FR) Incorrect
 (SV) Fel
 (NL) Fout
 (ES) Erróneo
 (IT) Sbagliato
 (FI) Väärin



- (DE) Positionspfeil
 (EN) Location/Position Arrow
 (FR) Flèche de Position
 (SV) Positionpil
 (NL) Lokatie/Positie pijl
 (ES) Flecha de posición
 (IT) Freccia di posizione
 (FI) Paikannusnuoli



- (DE) Bewegungspfeil
 (EN) Movement Arrow
 (FR) Flèche de mouvement
 (SV) Rörelsepil
 (NL) Richtingspijl
 (ES) Flecha de movimiento
 (IT) Freccia di movimento
 (FI) Liikesuuntanuoli



- (DE) Achtung
 (EN) Warning
 (FR) Attention
 (SV) Varning
 (NL) Let op
 (ES) Atención
 (IT) Attenzione
 (FI) Huomio



- (DE) Abklemmen
 (EN) Disconnect
 (FR) Déconnecter
 (SV) Koppla los
 (NL) Demonteren
 (ES) Desconectar
 (IT) Staccare
 (FI) Irrota



- (DE) Verbinden
 (EN) Connect
 (FR) Connecter
 (SV) Ansult
 (NL) In elkaar
 (ES) Conectar
 (IT) Collegare
 (FI) Yhdistä



- (DE) Siehe
 (EN) Look/See
 (FR) Voir
 (SV) Se
 (NL) Kijken naar
 (ES) Ver
 (IT) Vedere
 (FI) Katso

Lieferumfang
Scope of delivery
Fourniture

Leveransomfattning
Leveringsomvang
Alcance de suministro

Contenuto della confezione
Toimituksen sisältö

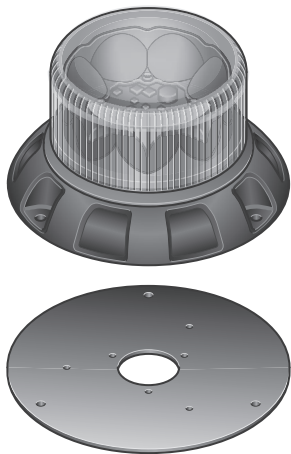

2XD 066 146-001



2XD 066 146-031

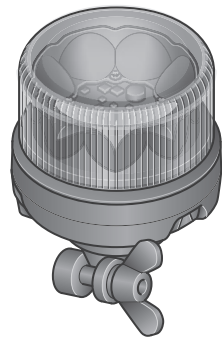

2XD 066 146-011

Zubehör
Accessories
Accessories

Tillbehör
Toebehoren
Accessorios

Accessori
Lisätarvikkeet

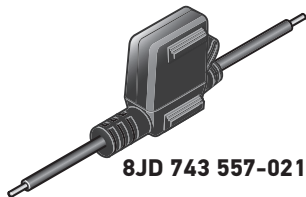

8JD 743 557-021



8KW 732 580-003



3A 8JS 711 683-821

Benötigte Montagewerkzeuge
Installation tools required
Outillage de montage requis

Nödvändiga monteringsverktyg
Benodigde montagewerktuigen
Herramientas de montaje necesarias

Attrezzi necessari per il montaggio
Tarvittavat asennustyökalut

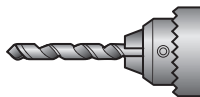

max. Ø5 mm



CLEANER

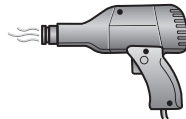
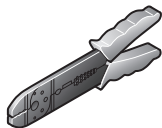
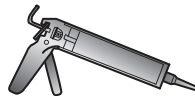

Montage
Mounting
Montage Général

Montering
Montage
Montaje

Montaggio
Asennus

DE Nicht geeignet für den Einsatz in schwefelhaltiger Atmosphäre.

EN Not suitable for use in sulfurous atmosphere.

FR Ne convient pas pour une utilisation en atmosphère sulfureuse.

SV Ej lämplig för användning i svavelhaltig atmosfär.

NL Niet geschikt voor gebruik in een zwavelhoudende atmosfeer.

ES No apto para uso en atmósfera sulfurosa.

IT Non adatto per l'uso in un'atmosfera solforosa.

FI Ei soveltu rikkipitoiseen ilmakehään.

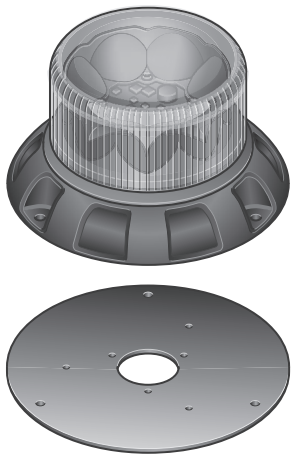
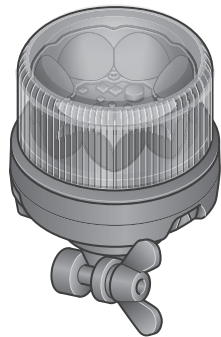
**12, 13****14, 15****16, 17**

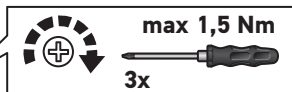
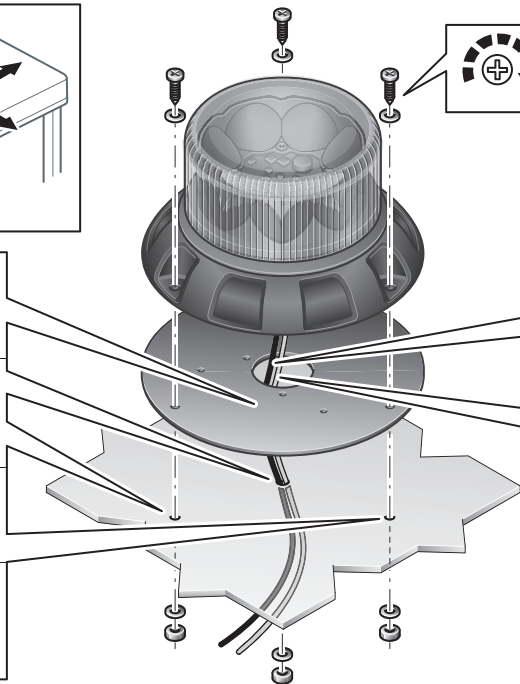
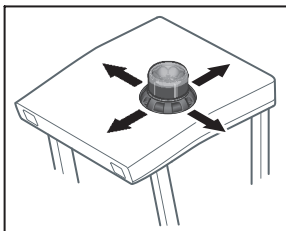



 schwarz
 black
 noir
 svart
 zwart
 negro
 nero
 musta

 weiß
 white
 blanc
 vit
 wit
 blanco
 bianco
 valkoinen

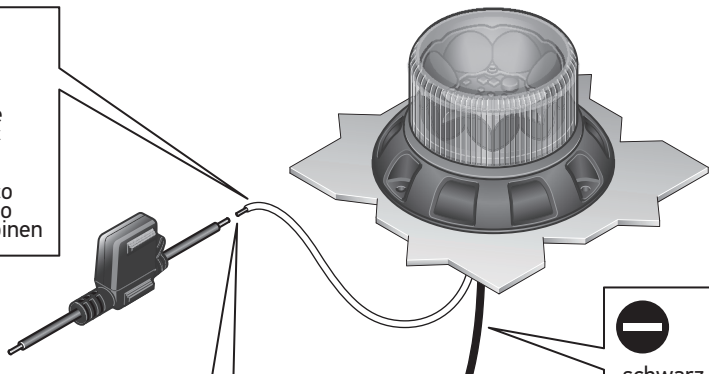

weiß
white
blanc
vit
wit
blanco
bianco
valkoinen



schwarz
black
noir
svart
zwart
negro
nefro
musta



10mm

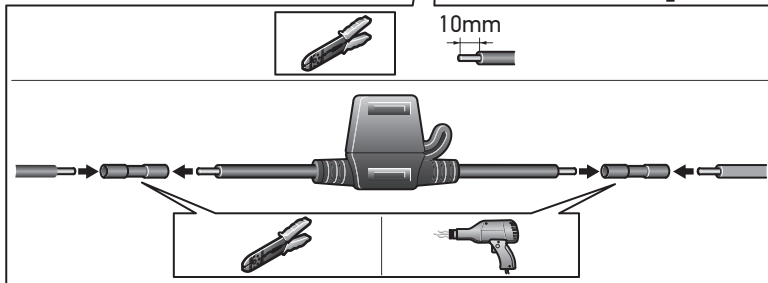

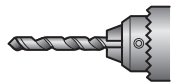
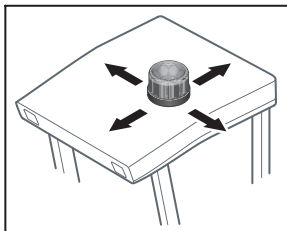

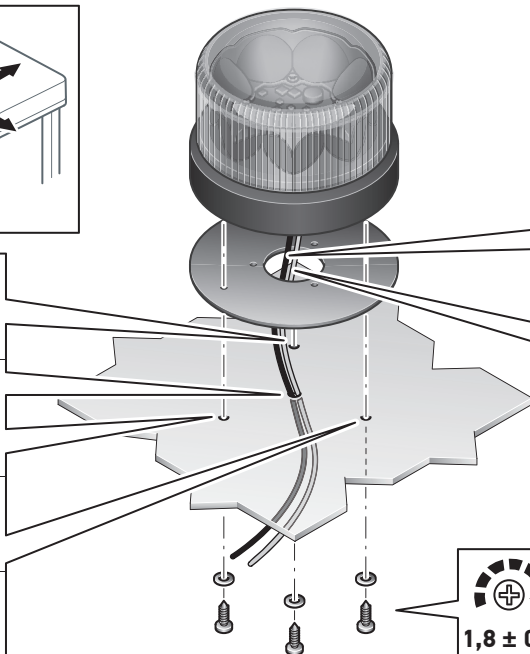
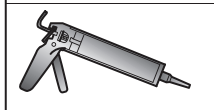

max. Ø5 mm



 schwarz
 black
 noir
 svart
 zwart
 negro
 nero
 musta



 weiß
 white
 blanc
 vit
 wit
 blanco
 bianco
 valkoinen



 1,8 ± 0,2 Nm

PT (WN 5411 H 4 x12 mm)

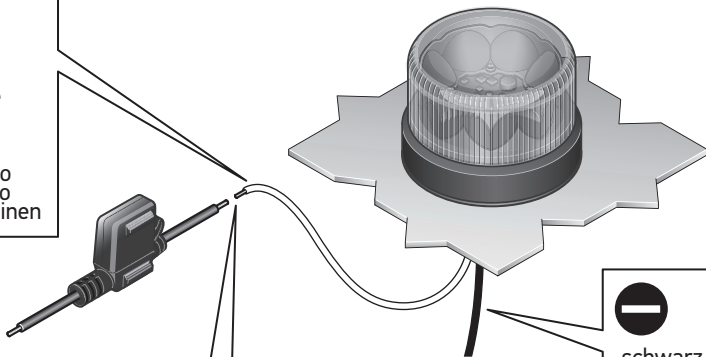

weiß
white
blanc
vit
wit
blanco
bianco
valkoinen



schwarz
black
noir
svart
zwart
negro
nero
musta



10mm

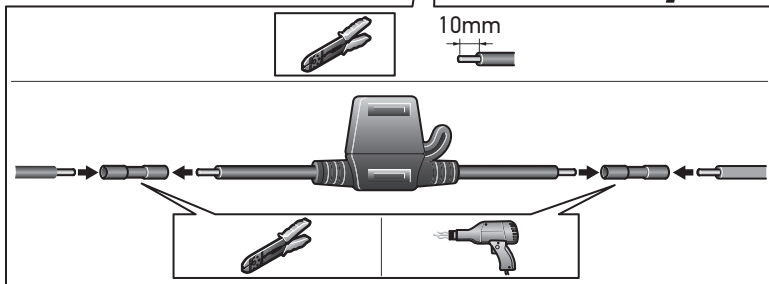

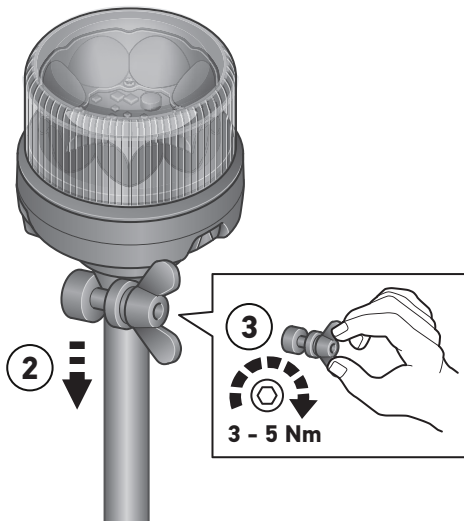
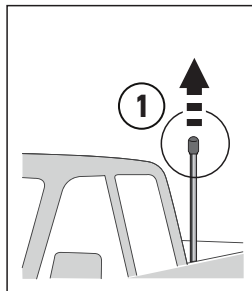
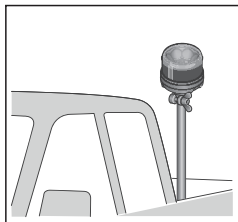

DE	Informationstext	18
EN	Information Text	19
FR	Texte d'information	20
SV	Informationstext	21
NL	Informatie tekst	22
ES	Texto informativo	23
IT	Informazioni	24
FI	Ohjetekstit	25

Einleitung:

Auf großen Flächen oder in engen Gassen, in der Halle oder im Außenbereich sind Flurförderfahrzeuge verschiedenster Art im Einsatz.

Ausführungen:

- Festanbau- Kennleuchte mit Anschlusslitzen und Unterlage.
- DIN 14620 flexibler Rohrstützen für Rohr Montage.

Technische Daten

Typprüfung	066 146-XXX Blitzend SAE-J845 Klasse 1 ECE-R65 TA1 (E1) 005218 ECE-R10 (E1) 10R – 069366
Gesamtstromaufnahme	10-30V: ca. 10 V - 1,0 A 30 V - 0,7 A
Entstörklasse	CISPR25 Klasse 5
Leistungsaufnahme	12V / 24: ca. 19W
Lichthaube	PC
Gebrauchslage	stehend
Schutzart	IP 6K7, IP 6K9
Temperaturbereich	minus 40 °C bis plus 60 °C
Verpolschutz	ja
Gehäuse	PC + ABS schwarz

Introduction:

Industrial trucks of highly varying types are in use in large areas and in close quarters, in halls as well as outdoor areas.

Versions:

- Permanently attached beacons with stranded connection wires and base.
- DIN 14620 a flexible pipe connection for pipe mounting.

Technical Data

Type approval:	066 146-XXX Flashing SAE-J845 Class 1 ECE-R65 TA1 (E1) 005218 ECE-R10 (E1) 10R – 069366
Total current consumption	10-30V: approx. 10V - 1,0 A 30V - 0,7 A
Interference suppression class	CISPR25 Class 5
Power consumption	12 V / 24V: 19W
Dome	PC
Operating position	Upright
Protective rating	IP 6K7, IP 6K9
Temperature range	minus 40 °C to plus 60 °C
Inverse polarity protection	yes
Housing	PC + ABS black

Introduction :

Toutes sortes d'engins de manutention sont utilisés dans toutes sortes d'endroits : sur de vastes espaces, dans des allées étroites, dans des hangars, à l'extérieur.

Conceptions :

- Feu rotatif à montage fixe avec torons de raccordement et support.
- DIN 14620 une tubulure flexibles pour installation de conduites.

Caractéristiques techniques

Homologation:	066 146-XXX Clignotant SAE-J845 Classe 1 ECE-R65 TA1 (E1) 005218 ECE-R10 (E1) 10R - 069366
Courant total absorbé	10-30V: env. 10 V - 1,0 A 30 V - 0,7 A
Classe de déparasitage	CISPR25 Classe 5
Puissance absorbée	12 V / 24V: 19W
Cabochon	PC
Position d'utilisation	debout
Indice de protection	IP 6K7, IP 6K9
Plage de température	moins 40 °C à plus 60 °C
Protection contre les inversions de polarité	oui
Boîtier	PC + ABS noir

Inledning:

På öppna ytor eller i trånga gränder, i hallar eller utomhus används industritruckar av olika slag.

Utföranden:

- Varningsfyr för fast montering med anslutningslits och underlägg.
- DIN 14620 prilagodljivo vtičnice cevi za namestitvev cevi.

Tekniska data

Typprovning:	066 146-XXX Blinkande SAE-J845 Klass 1 ECE-R65 TA1 (E1) 005218 ECE-R10 (E1) 10R - 069366
Total strömupptagning	10-30V: ca. 10V - 1,0A 30V - 0,7A
Avstörningsklass	CISPR25 Klass 5
Effektförbrukning	12 V / 24V: 19W
Ljushuv	PC
Användningsläge	Stående
Kapslingstyp	IP 6K7, IP 6K9
Temperaturområde	minus 40 °C till plus 60 °C
Polomkastningsskydd	ja
Hus	PC + ABS svart

Inleiding:

In grote ruimtes of smalle steegjes, in de loods of buiten: overal zijn de meest uiteenlopende transportvoertuigen in gebruik.

Uitvoeringen:

- Zwaailicht voor vaste montage met aansluitkabel en onderplaat.
- DIN 14620 een flexibele buis aansluitingen voor leidingen installeren.

Technische gegevens

Typekeuring	066 146-XXX Knipperend SAE-J845 Klasse 1 ECE-R65 TA1 (E1) 005218 ECE-R10 (E1) 10R - 069366
Totale stroomverbruik	10-30V: ca. 10 V - 1,0 A 30 V - 0,7 A
Ontstoringsklasse	CISPR25 Klasse 5
Vermogensopname	12 V / 24V: 19W
Lichtkap	PC
Toepassingsstand	staand
Beschermsoort	IP 6K7, IP 6K9
Temperatuurbereik	min 40 °C tot plus 60 °C
Poolinversiebeveiliging	ja
Behuizing	PC + ABS zwart

Introducción:

En grandes superficies o en calles estrechas, dentro de naves industriales o en el exterior se utilizan vehículos industriales de distintos tipos.

Versiones:

- Luz de señalización para montaje fijo con cables de conexión y base.
- DIN 14620 a racores tubulares flexibles para la instalación de tuberías.

Datos técnicos

Formato de la homologación de tipo:	066 146-XXX Brillante SAE-J845 Clase 1 ECE-R65 TA1 (E1) 005218 ECE-R10 (E1) 10R - 069366
Consumo de corriente total	10-30V: aprox. 10V - 1,0A 30V - 0,7A
Clase de supr. de interf.	CISPR25 Clase 5
Consumo de potencia	12 V / 24V: 19W
Cubierta	PC
Posición de empleo	de pie
Tipo de protección	IP 6K7, IP 6K9
Intervalo de temperatura	- 40 °C a + 60 °C
Protección ante inv. de polaridad	sí
Carcasa	PC + ABS negro

Introduzione:

In spazi ampi o in spazi stretti, al coperto o all'aperto: i veicoli trasporto interno utilizzati sono di tipo diverso.

Versioni:

- Girevole per montaggio fisso con cavetti di collegamento e base.
- DIN 14620 un raccordo tubo flessibile per il montaggio tubo.

Dati tecnici	
Omologazione:	066 146-XXX Lampeggiante SAE-J845 Classe 1 ECE-R65 TA1 (E1) 005218 ECE-R10 (E1) 10R - 069366
Assorbimento complessivo di corrente	10-30V: ca. 10 V - 1,0 A 30 V - 0,7 A
Classe di soppressione delle interferenze	CISPR25 Classe 5
Potenza assorbita	12 V / 24V: 19W
Calotta	PC
Posizione d'impiego	Eretta
Classi di protezione	IP 6K7, IP 6K9
Intervallo di temperatura	Da meno 40 °C a più 60 °C
Protezione contro l'inversione della polarità	Sì
Alloggiamento	PC + ABS nero

Johdanto:

Suurilla alueilla tai ahtaissa paikoissa, hallissa tai ulkoalueella käytetään erilaisia kuljetusajoneuvoja.

Mallit:

- Kiinteästi asennettava tunnistusvalolamppu jossa on liitäntäjohtimet ja alusta.
- DIN 14620 joustava putkiliitäntä putkiasennukseen.

Tekniset tiedot	
Tyyppihyväksyntä, muoto:	066 146-XXX Vilkkuu SAE-J845 Luokka 1 ECE-R65 TA1 (E1) 005218 ECE-R10 (E1) 10R – 069366
Kokonaisvirrankulutus	10-30V: noin 10V - 1,0 A 30V - 0,7 A
EMC-radiohäiriösuojausluokka	CISPR25 Luokka 5
Tehonotto	12 V / 24V: 19W
Koppa	PC
Käyttöasento	pystyasento
Suojausluokka	IP 6K7, IP 6K9
Lämpötila-alue	-40 °C - +60 °C
Navoitussuoja	kyllä
Kotelo	PC + ABS musta

DE Beleuchtungsanlage auf einwandfreie Funktion hin prüfen

EN Check that the lighting system is working perfectly

FR Contrôler le bon fonctionnement de l'installation d'éclairage

SV Kontrollera att ljussystemet fungerar felfritt

NL Controleer of de verlichting goed functioneert

ES Comprobar que el sistema de iluminación funciona impecablemente

IT Controllare la perfetta funzionalità dell'impianto di illuminazione

FI Tarkasta valaistusjärjestelmän toiminta

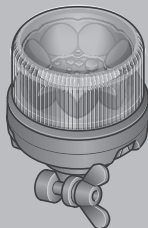
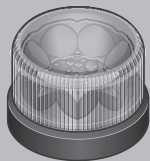
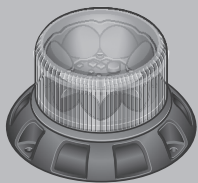

HELLA GmbH & Co. KGaA

Rixbecker Straße 75

59552 Lippstadt / Germany

www.hella.com

© HELLA GmbH & Co. KGaA, Lippstadt
460 909-33 / 11.21