

MONTAGEANLEITUNG
ARBEITSSCHEINWERFER
INSTALLATION INSTRUCTION
WORK LAMPS
INSTRUCTIONS DE MONTAGE
PROJECTEUR DE TRAVAIL
MONTERINGSANVISNING
ARBETSSTRÅLKASTARE
MONTAGEHANDLEIDING
WERKLAMP
INSTRUCCIONES DE MONTAJE
FARO DE TRABAJO
ISTRUZIONI DI MONTAGGIO
FARO DE LAVORO
ASENNUSOHJE
TYÖVALONEHEITINTÄ

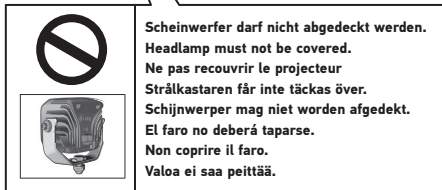
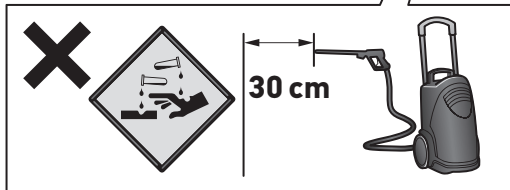
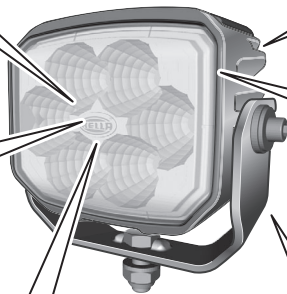
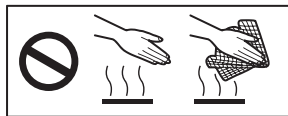

DE PRODUKTHAFTUNG

- Es sind die nationalen Anbau-, Einbau- und Betriebsvorschriften zu beachten und einzuhalten.
- Lesen Sie bitte vor Gebrauch des Gerätes alle beigelegten Anleitungen und Sicherheits-hinweise.
- Im Zuge von Produktverbesserung behalten wir uns technische und optische Änderungen vor.
- Verwenden Sie nur die Originalersatzteile bzw. nur Ersatzteile die von HELLA freigegeben sind.
- Bei Fragen oder Einbauproblemen, wenden Sie sich bitte an den HELLA Kundendienst, den Großhändler oder an Ihre Werkstatt.
- Weitere Informationen finden Sie auch auf unserer Internetseite (www.hella.com/techworld)

EN PRODUCT LIABILITY

- National mounting, fitting and operating regulations must be heeded and kept.
- Please read all the instructions and safety notes included before using the device.
- We reserve the right to make technical and optical modifications within the course of product improvement.
- Only use original spare parts or spare parts approved by HELLA.
- If you have any questions or problems with the installation, please contact HELLA Customer Services, a wholesaler or your garage.
- Further information is available on our website (www.hella.com/techworld)

FR RESPONSABILITÉ PRODUIT

- Les prescriptions nationales en matière de montage et de service doivent être observées et respectées.
- Avant d'utiliser l'appareil lire toutes les instructions de montage et de service fournies ainsi que les conseils de sécurité.
- Dans le cadre de l'amélioration continue de nos produits, nous nous réservons le droit de réaliser des modifications sur les plans technique et optique.
- Utilisez uniquement des pièces d'origine ou des pièces de rechange validées par HELLA.
- Pour toute question ou en cas de problèmes de montage, veuillez contacter le S.A.V. ou le distributeur HELLA ou bien vous adresser à votre garagiste.
- Vous trouverez également des informations complémentaires sur notre site Internet (www.hella.com/techworld)

SV PRODUKTANSVAR

- De nationella monterings-, installations- och driftföreskrifterna ska beaktas och följas.
- Läs alla medföljande instruktioner och säkerhetsanvisningar innan du använder apparaten.
- Vi förbehåller oss rätten till tekniska och optiska ändringar som förbättrar produkten.
- Använd endast original reservdelar resp. endast reservdelar som har godkänts av HELLA.
- Vid frågor eller monteringsproblem, kontakta HELLA kundtjänst, grossisten eller din verkstad.
- Mer information finns också på vår webbplats (www.hella.com/techworld)

NL PRODUCTAANSPRAKELIJKHEID

- Men dient de nationale aanbouw-, inbouw- en bedrijfsvoorschriften in acht te nemen en na te leven.
- Lees a.u.b. alvorens het apparaat te gebruiken alle bijgevoegde gebruiksaanwijzingen en veiligheidsinstructies door.
- In het kader van de productver-betering behouden wij ons technische en optische veranderingen voor.
- Gebruik uitsluitend de originele reserveonderdelen, die door Hella vrijgegeven zijn.
- Neem bij vragen of inbouwproblemen contact op met de HELLA klantenservice, de groothandel of het garagebedrijf.
- Meer informatie is ook te vinden op onze website (www.hella.com/techworld)

ES RESPONSABILIDAD CIVIL POR PRODUCTOS DEFECTUOSOS

- Tienen que observarse y cumplirse con las prescripciones nacionales sobre construcciones anexas, de montaje y de funcionamiento.
- Rogamos que antes de usar el aparato lean todas las instrucciones y advertencias sobre la seguridad adjuntas.
- En aras de la mejora de los productos, nos reservamos el derecho de hacer modificaciones técnicas y ópticas.
- Use sólo recambios originales o bien sólo recambios autorizados por HELLA.
- En caso de dudas o preguntas a la hora del montaje, llame al servicio de atención al cliente de HELLA o diríjase a su Distribuidor o Taller.
- Encontrará más información en nuestra página web (www.hella.com/techworld)

IT RESPONSABILITÀ PER IL PRODOTTO

- Si devono rispettare tutte le normative nazionali di attacco, montaggio e funzionamento.
- Prima di usare l'apparecchio, legga per favore tutte le istruzioni e le avvertenze di sicurezza allegate.
- Nell'ambito del perfezionamento del prodotto, ci riserviamo modifiche tecniche ed estetiche.
- Utilizzare solo pezzi di ricambio originali risp. pezzi autorizzati dalla HELLA.
- Per eventuali domande o problemi di installazione contattare l'Assistenza Clienti HELLA, il grossista o rivolgersi alla propria officina.
- Ulteriori informazioni sono disponibili anche sul nostro sito web (www.hella.com/techworld)

FI TUOTEVASTUU

- Kansalliset asennus- ja käyttöohjeet on huomioitava ja niitä on noudatettava.
- Lue ennen laitteen käyttöä kaikki oheistetut käyttö- sekä turvaohjeet.
- Jatkuvasta tuotekehittelystä johtuen pidätämme oikeuden teknisiin ja optisiin muutoksiin.
- Käytä vain alkuperäisiä tai HELLA hyväksymiä varaosia.
- Jos sinulla on kysyttävää tai asennusongelmia, käänny HELLA-asiakaspalvelun, tukkuliikkeen tai korjaamon puoleen.
- Lisätietoja löytyy verkkosivustoltamme (www.hella.com/techworld).

DE Technische Änderungen vorbehalten

EN Subject to alteration without notice

FR Sous réserve de modifications techniques

SV Vi reserverar oss för tekniska ändringar

NL Technische wijzigingen voorbehouden

ES Reservadas modificaciones técnicas

IT Con riserva di modifiche tecniche

FI Oikeus teknisiin muutoksiin pidätetään

Zeichenerklärung
Explanation symbols
Explication des symboles

Symbolförklaring
Legenda
Aclaración de símbolos

Legenda
Piirroksen selitys



- (DE)** Richtig
- (EN)** Correct
- (FR)** Correct
- (SV)** Rätt
- (NL)** Goed
- (ES)** Correcto
- (IT)** Giusto
- (FI)** Oikein



- (DE)** Falsch
- (EN)** Incorrect
- (FR)** Incorrect
- (SV)** Fel
- (NL)** Fout
- (ES)** Erróneo
- (IT)** Sbagliato
- (FI)** Väärin



- (DE)** Positionspfeil
- (EN)** Location/Position Arrow
- (FR)** Flèche de Position
- (SV)** Positionpil
- (NL)** Lokatie/Positie pijl
- (ES)** Flecha de posición
- (IT)** Freccia di posizione
- (FI)** Paikannusnuoli



- (DE)** Bewegungspfeil
- (EN)** Movement Arrow
- (FR)** Flèche indiquant sens du vouvement
- (SV)** Rörelsepil
- (NL)** Richtingspijl
- (ES)** Flecha de moviemento
- (IT)** Freccia di movimentov
- (FI)** Liikesuuntanuoli



- (DE)** Achtung
- (EN)** Warning
- (FR)** Attention
- (SV)** Varning
- (NL)** Let op
- (ES)** Atención
- (IT)** Attenzione
- (FI)** Huomio



- (DE)** Abklemmen
- (EN)** Disconnect
- (FR)** Déconnecter
- (SV)** Koppla los
- (NL)** Demonteren
- (ES)** Desconectar
- (IT)** Staccare
- (FI)** Irrota



- (DE)** Verbinden
- (EN)** Connect
- (FR)** Connecter
- (SV)** Anslut
- (NL)** In elkaar
- (ES)** Conectar
- (IT)** Collegare
- (FI)** Yhdistä



- (DE)** Siehe
- (EN)** Look/See
- (FR)** Voir
- (SV)** Se
- (NL)** Kijkjen naar
- (ES)** Ver
- (IT)** Vedere
- (FI)** Katso

Zubehör
Accessories
Accessories

Tillbehör
Toebehoren
Accessorios

Accessori
Lisätarvikkeet



6EH 007 946-001



7,5A 8JS 711 685-821

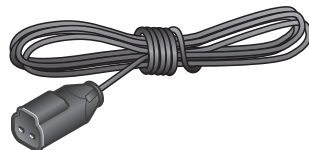

8KB 990 299-011



8JD 005 235-801



8KW 744 697-003

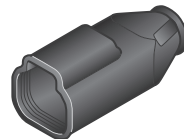

9GH 990 316-027

Benötigte Montagewerkzeuge
Installation tools required
Outilsage de montage requis

Nödvändiga monteringsverktyg
Benodigde montagewerktuigen
Herramientas de montaje necesarias

Attrezzi necessari per il montaggio
Tarvittavat asennustyökalut

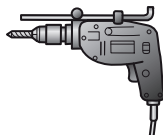
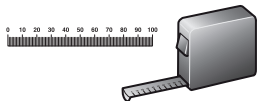

12 / 13
16 / 17

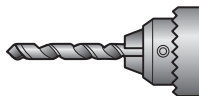

Ø10,5 mm



5

Montage
Mounting
Montage Général

Montering
Montage
Montaje

Montaggio
Asennus

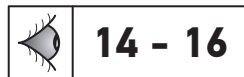
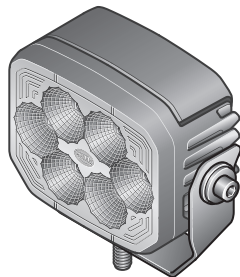
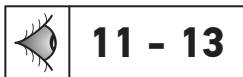
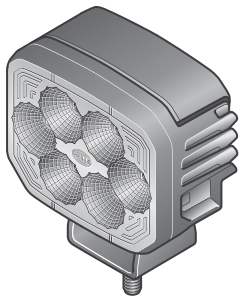

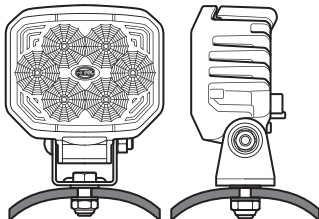
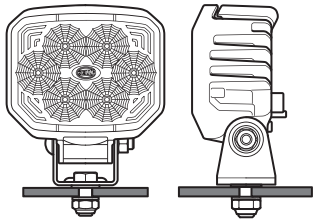
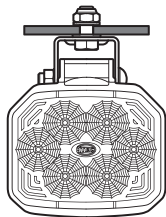
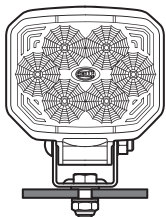

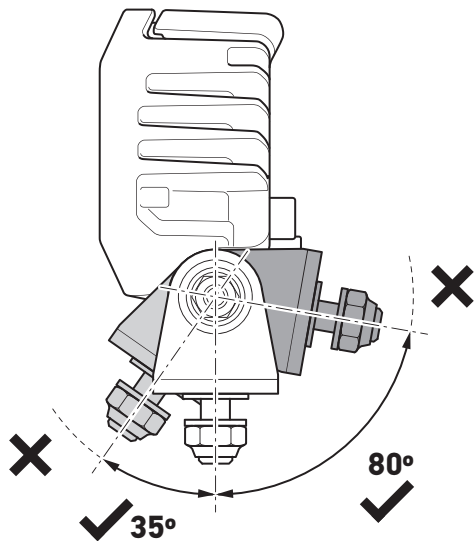

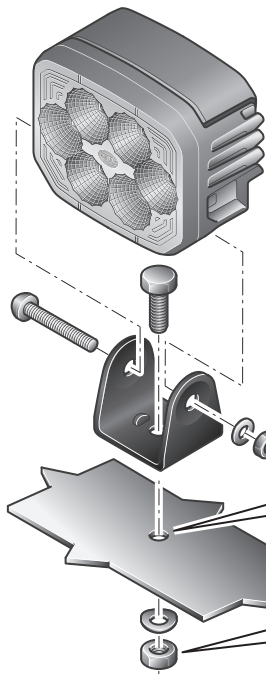

13



996 188-XXX = max. 15 Nm

996 388-XXX = max. 10 Nm

996 488-XXX = max. 15 Nm



Ø10,5 mm



16,17

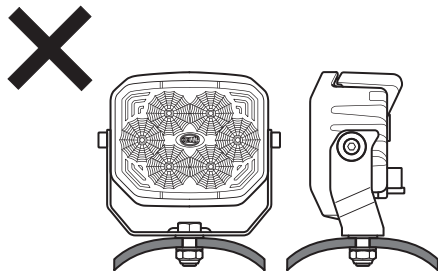
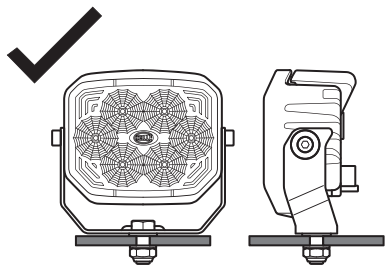
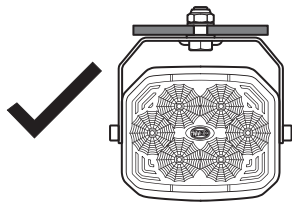
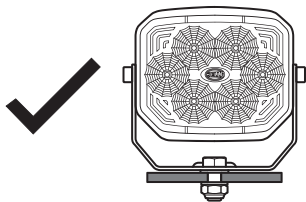

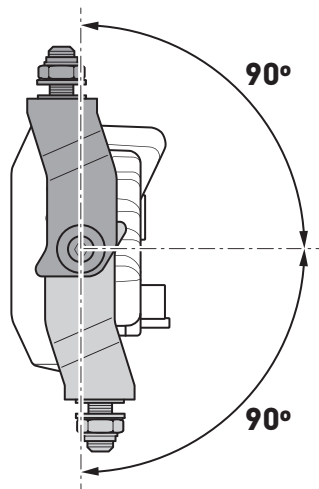

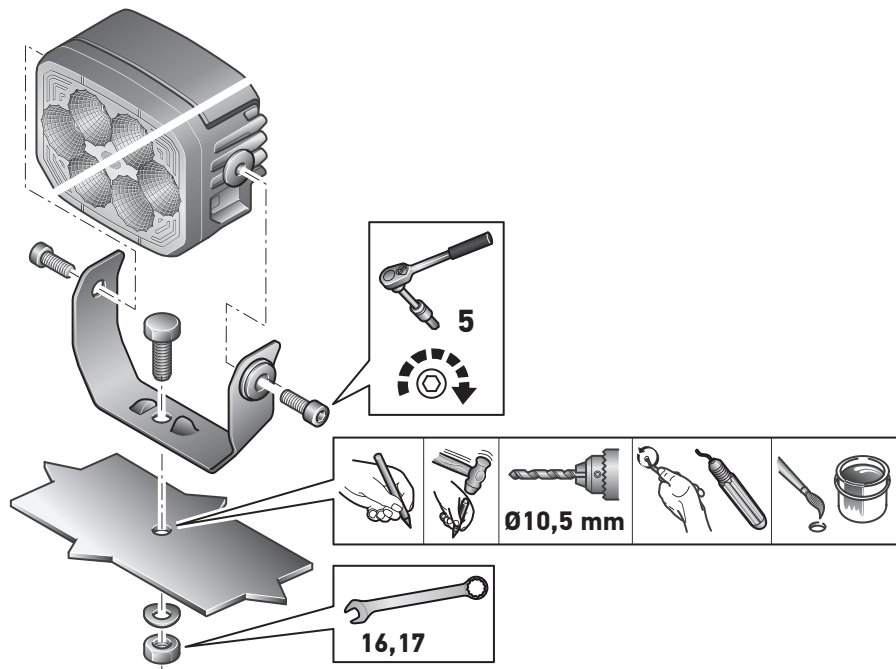

Elektrischer Anschluss
Electrical connection
Branchement électrique

Elektrisk anslutning
Elektrische aansluiting
Conexión eléctrica

Collegamento elettrico
Osaluuttelo

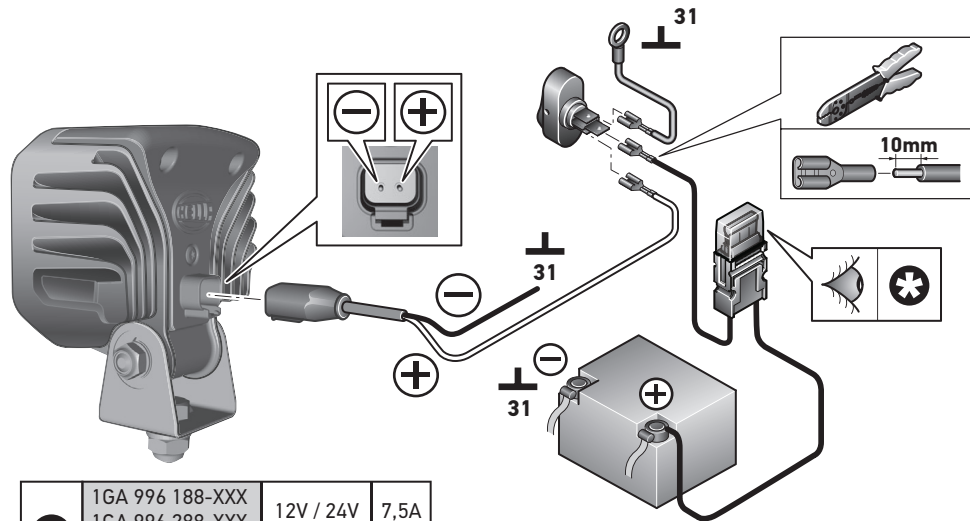

✱	1GA 996 188-XXX	12V / 24V	7,5A
	1GA 996 288-XXX		
✱	1GA 996 388-XXX	12V / 24V	7,5A
	1GA 996 488-XXX		

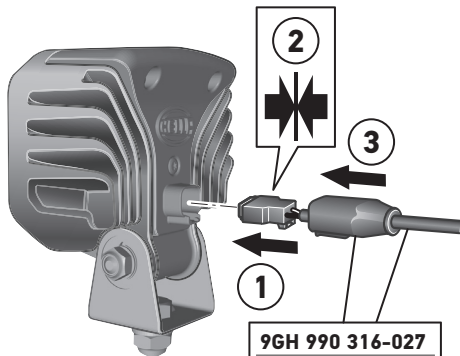

9GH 990 316-027
8KB 990 299-011

Empfehlung
Recommendation
Recommandation
Aanbeveling
Recomendación
Raccomandazione
Suositus

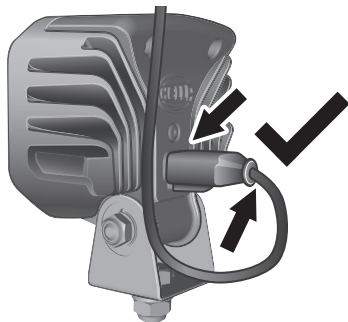
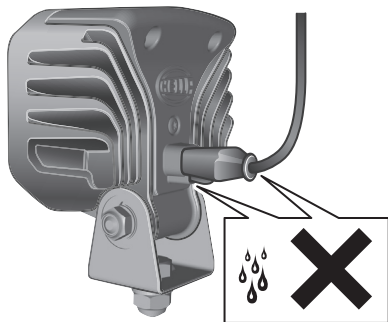

DE	Informationstext	20
EN	Information Text	20
FR	Texte d'information	21
SV	Informationstext	21
NL	Informatie tekst	22
ES	Texto informativo	22
IT	Informazioni	23
FI	Ohjetekstit	23

DE TECHNISCHE DATEN

	Nennspannung	Spannungsbereich	Eingangswerte	Zulässige Umgebungstemperatur	Schutzklasse
1GA 996 188-XXX	12V	10,5V - 32V	< 1,3 A < 13 W	-40° C bis +50° C	IP 6K 9K, IP 6K8
	24V	10,5V - 32V	< 0,85 A < 13 W		
1GA 996 288-XXX	12V	10,5V - 32V	< 2,0 A < 20 W		
	24V	10,5V - 32V	< 1,3 A < 20 W		
1GA 996 388-XXX	12V	10,5V - 32V	< 2,6 A < 27,5 W		
1GA 996 488-XXX	24V	10,5V - 32V	< 1,7 A < 27,5 W		

Der Betrieb der Leuchte mit Wechselspannung ist nicht zulässig.

EN TECHNICAL DATA

	Nominal voltage	Range of voltage	Input values	Admissible ambient temperature	Class of protection
1GA 996 188-XXX	12V	10,5V - 32V	< 1,3 A < 13 W	-40°C up to +50°C	IP 6K 9K, IP 6K8
	24V	10,5V - 32V	< 0,85 A < 13 W		
1GA 996 288-XXX	12V	10,5V - 32V	< 2,0 A < 20 W		
	24V	10,5V - 32V	< 1,3 A < 20 W		
1GA 996 388-XXX	12V	10,5V - 32V	< 2,6 A < 27,5 W		
1GA 996 488-XXX	24V	10,5V - 32V	< 1,7 A < 27,5 W		

Operating lights with alternating voltage is not permitted.

FR DOCUMENT TECHNIQUE

	Tension nominale	Plage de tension	Valeurs d'entrée	Température ambiante admissible	Classe de protection
1GA 996 188-XXX	12V	10,5V - 32V	< 1,3 A < 13 W	-40°C à +50°C	IP 6K 9K, IP 6K8
	24V	10,5V - 32V	< 0,85 A < 13 W		
1GA 996 288-XXX	12V	10,5V - 32V	< 2,0 A < 20 W		
	24V	10,5V - 32V	< 1,3 A < 20 W		
1GA 996 388-XXX	12V	10,5V - 32V	< 2,6 A < 27,5 W		
1GA 996 488-XXX	24V	10,5V - 32V	< 1,7 A < 27,5 W		

Faire fonctionner les feux avec une tension alternative n'est pas autorisé.

SV TEKNISKA DATA

	Märk-spänning	Spänningsområde	Ingångsvärden	Tillåten omgivnings-temperatur	Skyddsklass
1GA 996 188-XXX	12V	10,5V - 32V	< 1,3 A < 13 W	-40°C upp till +50°C	IP 6K 9K, IP 6K8
	24V	10,5V - 32V	< 0,85 A < 13 W		
1GA 996 288-XXX	12V	10,5V - 32V	< 2,0 A < 20 W		
	24V	10,5V - 32V	< 1,3 A < 20 W		
1GA 996 388-XXX	12V	10,5V - 32V	< 2,6 A < 27,5 W		
1GA 996 488-XXX	24V	10,5V - 32V	< 1,7 A < 27,5 W		

Det är inte tillåtet att använda lampan med växelspanning.

NL TECHNISCHE GEGEVENS

	Nominale spanning	Spanningsbereik	Ingangswaarden	Toegestane omgevings-temperatuur	Beschermklasse
1GA 996 188-XXX	12V	10,5V - 32V	< 1,3 A < 13 W	-40°C tot +50°C	IP 6K 9K, IP 6K8
	24V	10,5V - 32V	< 0,85 A < 13 W		
1GA 996 288-XXX	12V	10,5V - 32V	< 2,0 A < 20 W		
	24V	10,5V - 32V	< 1,3 A < 20 W		
1GA 996 388-XXX	12V	10,5V - 32V	< 2,6 A < 27,5 W		
1GA 996 488-XXX	24V	10,5V - 32V	< 1,7 A < 27,5 W		

Het is niet toegestaan om het licht op wisselspanning te laten werken.

22

ES DATOS TÉCNICOS

	Tensión nominal	Margen de tensión	Valores de entrada	Temperatura ambiente admisible	Clase de protección
1GA 996 188-XXX	12V	10,5V - 32V	< 1,3 A < 13 W	-40°C hasta +50°C	IP 6K 9K, IP 6K8
	24V	10,5V - 32V	< 0,85 A < 13 W		
1GA 996 288-XXX	12V	10,5V - 32V	< 2,0 A < 20 W		
	24V	10,5V - 32V	< 1,3 A < 20 W		
1GA 996 388-XXX	12V	10,5V - 32V	< 2,6 A < 27,5 W		
1GA 996 488-XXX	24V	10,5V - 32V	< 1,7 A < 27,5 W		

No está permitido el funcionamiento de la lámpara con tensión alterna.

IT DATI TECNICI

	Tensione nominale	Intervallo di tensione	Valori di ingresso	Temperatura ambiente ammessa	Categoria di protezione
1GA 996 188-XXX	12V	10,5V - 32V	<1,3A <13W	da -40°C a +50°C	IP 6K 9K, IP 6K8
	24V	10,5V - 32V	<0,85A <13W		
1GA 996 288-XXX	12V	10,5V - 32V	<2,0A <20W		
	24V	10,5V - 32V	<1,3A <20W		
1GA 996 388-XXX	12V	10,5V - 32V	<2,6A <27,5W		
1GA 996 488-XXX	24V	10,5V - 32V	<1,7A <27,5W		

Non è ammesso il funzionamento delle luci con tensione alternata.

23

FI TEKNISET TIEDOT

	Nimellisjännite	Jännitealue	Tuloarvot	Sallittu ympäristölämpötila	Kotelointiluokka
1GA 996 188-XXX	12V	10,5V - 32V	<1,3A <13W	da -40°C a +50°C	IP 6K 9K, IP 6K8
	24V	10,5V - 32V	<0,85A <13W		
1GA 996 288-XXX	12V	10,5V - 32V	<2,0A <20W		
	24V	10,5V - 32V	<1,3A <20W		
1GA 996 388-XXX	12V	10,5V - 32V	<2,6A <27,5W		
1GA 996 488-XXX	24V	10,5V - 32V	<1,7A <27,5W		

Lampun käyttö vaihtojännitteellä ei ole sallittu.

DE Beleuchtungsanlage auf einwandfreie Funktion hin prüfen

EN Check that the lighting system is working perfectly

FR Contrôler le bon fonctionnement de l'installation d'éclairage

SV Kontrollera att ljussystemet fungerar felfritt

NL Controleer of de verlichting goed functioneert

ES Comprobar que el sistema de iluminación funciona impecablemente

IT Controllare la perfetta funzionalità dell'impianto di illuminazione

FI Tarkasta valaistusjärjestelmän toiminta

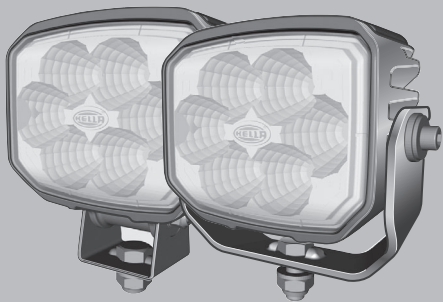

HELLA GmbH & Co. KGaA

Rixbecker Straße 75

59552 Lippstadt /Germany

www.hella.com

© HELLA GmbH & Co. KGaA, Lippstadt

460 879-52 /10.21