



ADR - APPLICATION AND MOUNTING INSTRUCTIONS
ADR 48/00 Licence Plate Lamp

LED NUMBER PLATE LAMP

Multivolt capable 10 - 33 volts

One Lamp must be mounted as follows

- The lamp mounting surface must be parallel with the number plate surface.
- One lamp must be mounted at either end of the number plate, refer to diagram 1 below.

Lens Marking and ADR 13/00 Installation Requirements

This Number Plate Lamp, identified by lens marking 9640 and the logo was manufactured to comply with ADR 48/00 Devices for Illumination of Rear Registration Plates:

- A tolerance of +/-3 degrees applies on all mounting details.
- Geometric visibility:
 - Such that the device illuminates the site of the registration plate.

NB: Only one lamp is required for ADR compliance. However two lamps can also be used, please contact HELLA for alternative mounting configurations.

Diagram 1

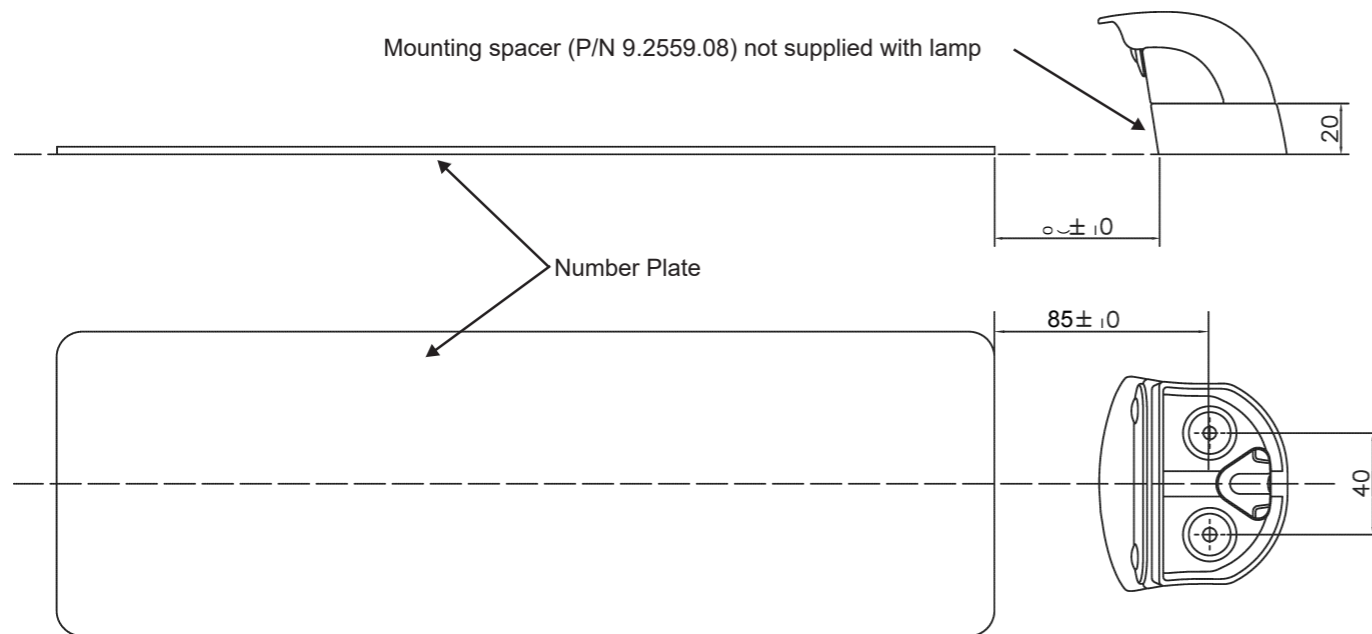

All dimensions in millimetres

PART NUMBER	CTA NUMBER	ADR 51/00 GLOBE	LENS IDENTIFICATION NO.
2559-1 2KA 959 640-3xx 959.640-3xx	CTA-041602	N/A LED	9640

HELLA-New Zealand Limited, Auckland



ADR - APPLICATION AND MOUNTING INSTRUCTIONS
ADR 48/00 Licence Plate Lamp

LED NUMBER PLATE LAMP

Multivolt capable 10 - 33 volts

One Lamp must be mounted as follows

- The lamp mounting surface must be parallel with the number plate surface.
- One lamp must be mounted at either end of the number plate, refer to diagram 1 below.

Lens Marking and ADR 13/00 Installation Requirements

This Number Plate Lamp, identified by lens marking 9640 and the logo was manufactured to comply with ADR 48/00 Devices for Illumination of Rear Registration Plates:

- A tolerance of +/-3 degrees applies on all mounting details.
- Geometric visibility:
 - Such that the device illuminates the site of the registration plate.

NB: Only one lamp is required for ADR compliance. However two lamps can also be used, please contact HELLA for alternative mounting configurations.

Diagram 1

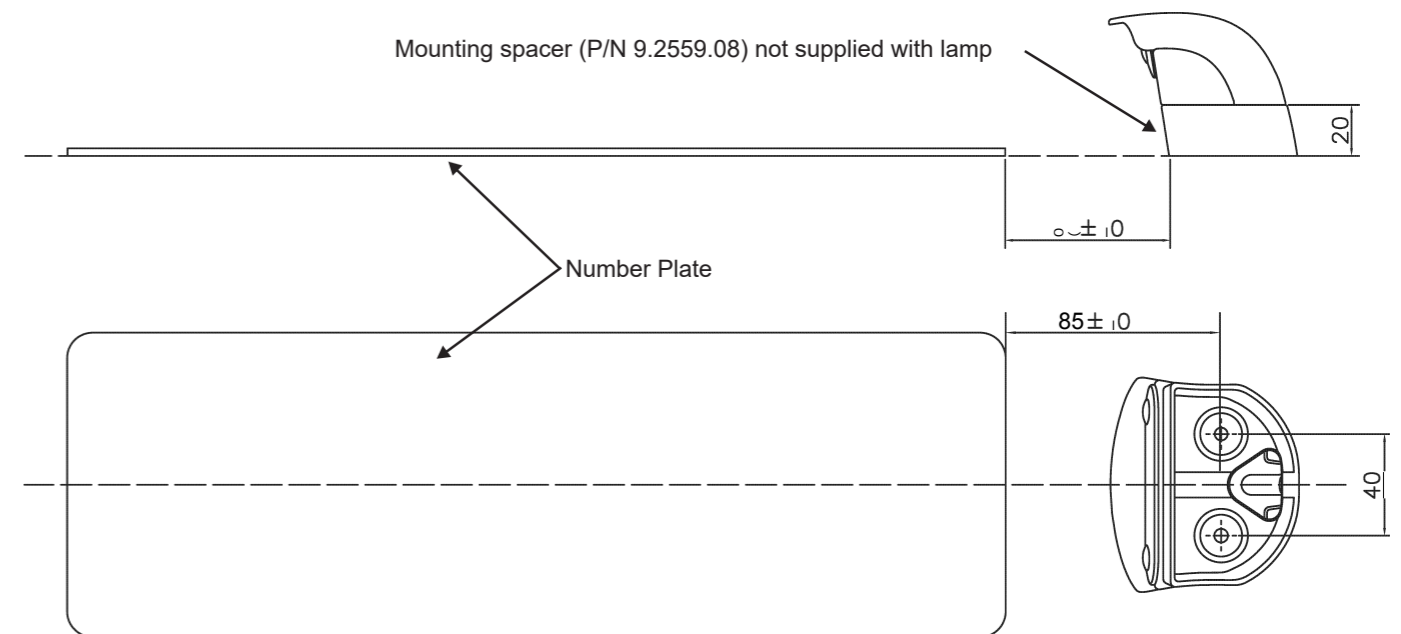

All dimensions in millimetres

PART NUMBER	CTA NUMBER	ADR 51/00 GLOBE	LENS IDENTIFICATION NO.
2559-1 2KA 959 640-3xx 959.640-3xx	CTA-041602	N/A LED	9640

HELLA-New Zealand Limited, Auckland

INSTRUCTION SHEET
for: **2KA 959 640-3xx / 2559-1**



Lamp Base Mounting Instructions

- Mounting holes up to 6.5mm Ø at 40mm centres, for 6 mm bolts, are recommended to mount the base using the mounting bushes provided (see diagram 2).
- For lamp mounting position see diagram 1 overleaf.
- If the lamp cable is to be routed through the mounting surface, ensure the cable hole has no sharp edges to cut or chafe the cable.
- Mounting spacer (P/N 9.2559.08) available as a spare part.

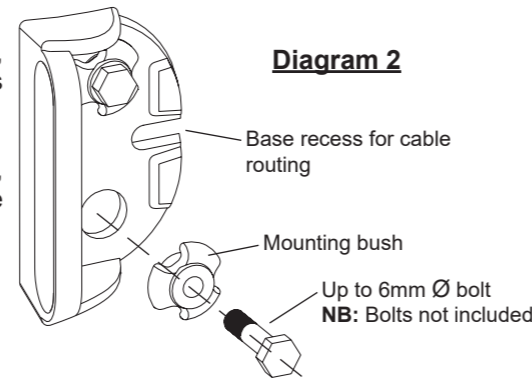

Lamp Module Instructions

- Pass cable through lamp module aperture in base and route through base.
- The cable can also be routed through the lamp cover by removing the material from the recess (see diagram 3).
- Locate the lamp module into the base, and place the locating lugs of the lamp cover into the base recesses.
- Mount the lamp module and cover with the supplied screws, and fit screw caps.

Diagram 3

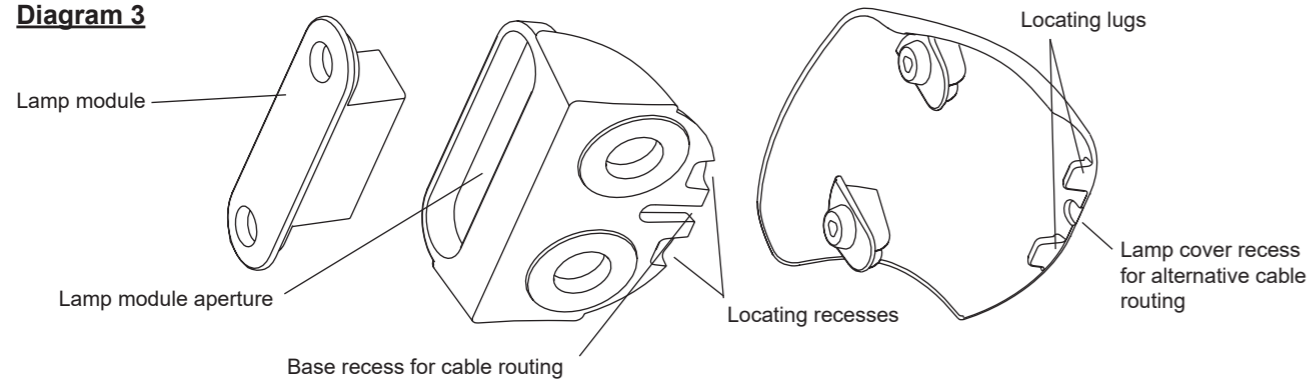

Wiring Colour Coding

The LED Number Plate Lamp is Multivolt capable allowing full light output between 10 and 33 volts. LED lamp modules are polarity conscious. Reverse polarity will not damage this product but will inhibit its function. HELLA recommends wire connections be soldered, and heat shrink tubing applied to seal the joint.

Colour	Connect to	Power Consumption
Black	Earth (-)	-
White (Red trace)	Positive (-)	0.5 watt

NB: Lamp must be protected by a fuse rated at 2 amperes maximum.

Compatibility to existing electrical systems

It is important for the installer to ascertain the compatibility of the low power consumption LED lamps with the electrical and/or electronic systems of the complete vehicle, including trailers. In most cases the reduced power consumption is beneficial by imposing less demands on the entire electrical system.

For certain functions some electrical systems rely on a set power consumption for monitoring whether, for example, a trailer is connected.

Operation of this lamp using alternating current or modulated direct voltage will cause premature light failure. HELLA recommends connecting ADR or ECE certified Multivolt LED signal and marker lamps to a continuous (unmodulated) 12V or 24V power supply to ensure safe light operation.

FIT AND FORGET - BY DESIGN

Congratulations, the product you have selected comes from **HELLA** - a world leader in LED lighting design.

Following the launch of the first LED automotive signal lamps in 1990, **HELLA** Design and Innovation continues to set new standards. **HELLA** innovative solutions have been incorporated into millions of lamps, engineered and tested to the most stringent standards, to suit the most demanding environmental conditions.

The cornerstone to the success of our products is our no compromise **Fit and Forget - by Design** philosophy which is incorporated into every step of the product life cycle.

In a world consuming finite resources at an ever faster rate, **Fit and Forget - by Design** is the right environmental choice that also makes perfect economic sense to customers that consider the total life cycle Cost of Ownership.

For general comments about HELLA's products please contact us on E-mail at techfeedback@hella.co.nz



INSTRUCTION SHEET
for: **2KA 959 640-3xx / 2559-1**



Lamp Base Mounting Instructions

- Mounting holes up to 6.5mm Ø at 40mm centres, for 6 mm bolts, are recommended to mount the base using the mounting bushes provided (see diagram 2).
- For lamp mounting position see diagram 1 overleaf.
- If the lamp cable is to be routed through the mounting surface, ensure the cable hole has no sharp edges to cut or chafe the cable.
- Mounting spacer (P/N 9.2559.08) available as a spare part.

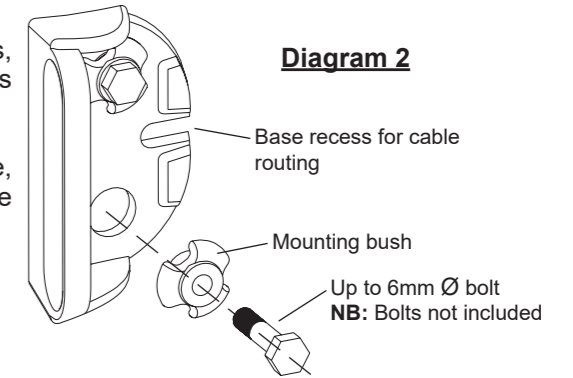

Lamp Module Instructions

- Pass cable through lamp module aperture in base and route through base.
- The cable can also be routed through the lamp cover by removing the material from the recess (see diagram 3).
- Locate the lamp module into the base, and place the locating lugs of the lamp cover into the base recesses.
- Mount the lamp module and cover with the supplied screws, and fit screw caps.

Diagram 3

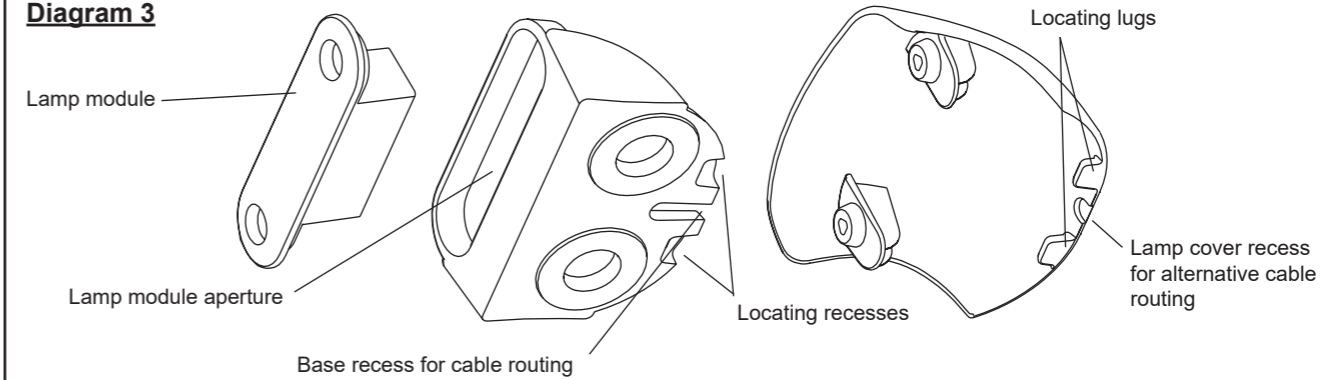

Wiring Colour Coding

The LED Number Plate Lamp is Multivolt capable allowing full light output between 10 and 33 volts. LED lamp modules are polarity conscious. Reverse polarity will not damage this product but will inhibit its function. HELLA recommends wire connections be soldered, and heat shrink tubing applied to seal the joint.

Colour	Connect to	Power Consumption
Black	Earth (-)	-
White (Red trace)	Positive (-)	0.5 watt

NB: Lamp must be protected by a fuse rated at 2 amperes maximum.

Compatibility to existing electrical systems

It is important for the installer to ascertain the compatibility of the low power consumption LED lamps with the electrical and/or electronic systems of the complete vehicle, including trailers. In most cases the reduced power consumption is beneficial by imposing less demands on the entire electrical system.

For certain functions some electrical systems rely on a set power consumption for monitoring whether, for example, a trailer is connected.

Operation of this lamp using alternating current or modulated direct voltage will cause premature light failure. HELLA recommends connecting ADR or ECE certified Multivolt LED signal and marker lamps to a continuous (unmodulated) 12V or 24V power supply to ensure safe light operation.

FIT AND FORGET - BY DESIGN

Congratulations, the product you have selected comes from **HELLA** - a world leader in LED lighting design.

Following the launch of the first LED automotive signal lamps in 1990, **HELLA** Design and Innovation continues to set new standards. **HELLA** innovative solutions have been incorporated into millions of lamps, engineered and tested to the most stringent standards, to suit the most demanding environmental conditions.

The cornerstone to the success of our products is our no compromise **Fit and Forget - by Design** philosophy which is incorporated into every step of the product life cycle.

In a world consuming finite resources at an ever faster rate, **Fit and Forget - by Design** is the right environmental choice that also makes perfect economic sense to customers that consider the total life cycle Cost of Ownership.

For general comments about HELLA's products please contact us on E-mail at techfeedback@hella.co.nz

