



**UNIVERSAL HEADLAMP  
MODULES**





# 60, 90 AND 133 MM MODULES – durable and powerful!

**HELLA headlamp modules stand for the highest quality, reliability and cost efficiency.**

Whether bus, tractor, truck, motorhome or motorbike: the robust HELLA headlamp modules are used in many types of vehicles. Thanks to their modular design, they offer maximum flexibility and a wide range of possible applications. The headlamp module range caters for both halogen and LED technology based on requirements, enabling an easy switch from halogen to LED. All modules impress with their robust construction and can therefore also be used in demanding work environments. They are all powerful, durable and reliable, and therefore stand for safety.

The difference is in the detail: The 60 mm module is one of our smallest modules and ensures a simple, clean vehicle design. In the 90 mm series, the L 4060 LED modules in particular outshine others with their outstanding light output and additional light functions. The Bi-LED modules combine low beam and high beam in a single headlamp module – ideal for constructions with limited space or special designs. Our largest, the 133 mm module, is available as a Bi-LED or Bi-halogen version. This means that low beam and high beam come from a single module, with either symmetrical or asymmetrical light distribution.

**Whether you opt for the 60, 90 or 133 mm module, you can rely on HELLA expertise when selecting the right headlamp modules because all our products guarantee a high level of safety and quality while being cost-efficient at the same time.**







## TABLE OF CONTENTS

Introduction	2
The module selector	4
Legend for icons	5
Product overview	6

### 60 mm modules

LED	8
Halogen	10

### 90 mm modules

LED – Essential	12
LED – Performance	14
Bi-LED – Essential	20
Bi-LED – Performance	21
Halogen – Performance	22
Bi-halogen – Performance	24

### 133 mm modules

Bi-LED	26
Bi-halogen	28

### Light distributions

90 mm modules	30
60 mm modules	32
133 mm modules	32

Mounting kits and carrier frames	34
Installation story	36
Accessories	38
Type approvals	42
Customer-specific headlamps	44
FAQs	46
Contact	47



Photo: © AIXAM-MEG



# A SOPHISTICATED SOLUTION: the smart module selector

Find the right headlamp module in just a few clicks:

Our smart module selector will make your search easier. Simply use the filter to select the required criteria, such as the lighting function or homologation, and you will see suitable products right away.

[www.hella.com/headlamp-modules](http://www.hella.com/headlamp-modules)



## + Simple menu structure and use

Our module selector is easy to use and makes it simple for original equipment manufacturers and end customers to find the right module – just like its predecessor, which has already proved its worth in practice. We have built on this and added further module types to the configurator.

## + Illumination comparison

Compare the lighting technology for selected main light functions: Spot the difference between halogen and LED with realistic images from Europe's largest light testing facility! Compare the light distribution and choose the one that suits your application.

## + Upgrade to modern LED technology

Existing halogen versions can be easily converted to LED modules. More detailed information is found in the assembly instructions supplied with the LED modules.

## + It is easy to order parts

Use the selector to easily create your order list and send it to HELLA.

## + Precise comparison

All key technical details for each module can be found in the detailed overview – including optional accessories!



# LEGEND

## Icons at a glance



**ECE**  
This product is approved according to ECE guidelines.



**Asymmetrical light distribution**  
The product complies with ECE regulation R149 Class B, which regulates asymmetrical low beam for passenger cars, buses, commercial vehicles and most larger vehicles.



**Symmetrical light distribution**  
The product complies with ECE regulation R149 Class DS, which regulates the symmetrical low beam for many agricultural vehicles and also for lighter vehicles (2, 3 or 4-wheeled).



**SAE**  
The product meets FMVSS 108 or ASABE S0608 type approval.



**CCC**  
Please contact us for the current certificate.



**Vehicle electrical system voltage**  
Defines the power supply of the lamp. This can be 12 V, 24 V or a flexible voltage range for multi-voltage (e.g. 8 – 33 V).



**Operating temperature**  
Thermal management and an optimised housing design ensure full functionality for all operating temperatures as a result of product testing from -40 °C to +60 °C, for example.



**Dust and water protection class - IP**  
International Protection (IP) according to DIN 40050, Part 9. Specific definition for road vehicles:

First digit: Protection against dust and dirt  
5K = dust protection  
6K = dust-tight

Second digit: Protection against water  
4K = protection against splashing water from any direction with increased pressure  
7 = protection against temporary immersion  
9K = protection against water during high-pressure/steam-jet cleaning

**Electronic circuit**  
Two different circuits are fundamentally possible for LED lamps.



Active:  
LED current regulation via active electronics.



Passive:  
Setting a specific voltage range for the LEDs by means of a series resistor.

**Thermal management**  
Active:  
Electronic power control of the LEDs when high ambient temperatures exceed permitted levels. This ensures that LEDs are protected against destruction caused by overheating.



Passive:  
Optimised layout of the components for even temperature distribution and spread.



**Polarity reversal protection**  
Even if the connecting cable is connected with reverse polarity, there is still no danger to the electronics.



**Electromagnetic compatibility**  
Electromagnetic compatibility (EMC) tested and EU type approval issued.



**Tourist solution (passive)**  
The lamp can be used without adjustments for a short time in countries with left-hand traffic.



AT A GLANCE

# Universal headlamp modules

LED

## 60 MM MODULES

LOW BEAM



Module 60 LED  
Page 8

HIGH BEAM



Module 60 LED  
Page 9

## 90 MM MODULES

LOW BEAM



L 4060  
Page 14

HIGH BEAM



L 4060  
Page 16

Performance:

Essential:



R 80  
Page 12



R 80  
Page 12

HALOGEN



Module 60  
Page 10



Module 60  
Page 11

Performance:



Page 22



Page 23

## 133 MM MODULES

### LOW BEAM AND HIGH BEAM



**Bi-LED L 4565**  
Page 21

### FOG LIGHT



**L 4060**  
Page 18

### LOW BEAM AND HIGH BEAM



**M133 LED (R149 Class DS)**  
Page 26



**M133 LED (R149 Class B)**  
Page 27



**Bi-LED L 4565**  
Page 20



Page 24



**M133 (R149 Class DS)**  
Page 28



**M133 (R149 Class B)**  
Page 29

90 mm diameter. Two lines. 100 % to the point.

HELLA 90 mm modules are subject to high standards that meet a wide range of requirements. However, there is also a common drive at HELLA to go beyond current standards and redefine them.

With the Essential and Performance lines, every requirement profile is met with an appropriate 90 mm module solution.

**Essential modules** offer very good illumination with high cost efficiency. Due to simple installation and intuitive features, these modules are suitable as an optimal entry-level solution.

**Performance modules** are market-leading low and high beam solutions with outstanding light output. Further features, such as additional light functions and zero-tolerance integration, are available alongside the performance characteristics.





## HOW IS THE HELLA PART NUMBER PUT TOGETHER?

HELLA

Classification number

Variant

1TL 998 670-021

Product family

Packaging index



### LED low beam headlamp Module 60 LED

ECE-R149 Class DS, SAE

1TL 998 670-021

ECE R149, Class DS, SAE, with pre-assembled carrier frame

1TL 998 670-041

Dimensional sketches of the LED low beam headlamp Module 60 LED

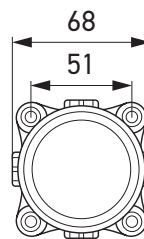

Without carrier frame

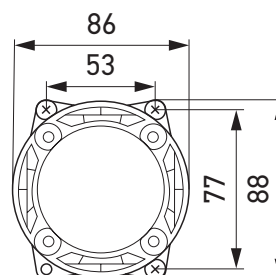
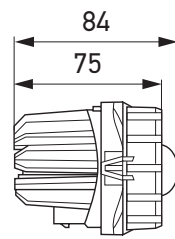

With carrier frame, vertical  
(Horizontal mounting also possible)

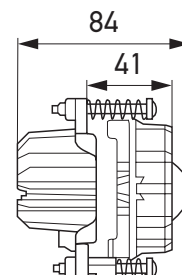





**LED**

Photo: © Traktorenwerk Lindner GmbH

60 MM MODULES

# LOW BEAM AND HIGH BEAM

## SPECIFICATIONS

- Especially compact LED headlamps
- Specially developed lens system for homogeneous illumination
- Enables an easy switch from halogen to LED technology
- Robust die-cast aluminium housing

### LED low and high beam headlamp Module 60 LED



### LED low beam headlamp Module 60 LED



### LED high beam headlamp Module 60 LED



For further information on each product, see general overview on page 42



### LED high beam headlamp Module 60 LED

ECE-R149 Class DS	1KL 998 670-031
ECE R149, Class DS, SAE, with pre-assembled carrier frame	1KL 998 670-051
ECE-R149 Class B	1KL 998 670-017

### Dimensional sketches of the LED high beam headlamp Module 60 LED

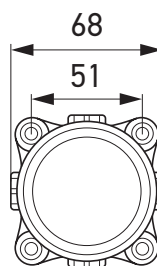

Without carrier frame

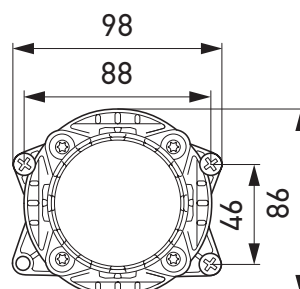
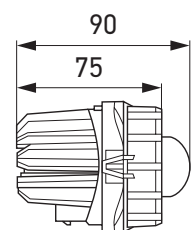

With carrier frame, horizontal  
(vertical mounting also possible)

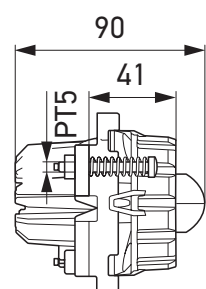





**Halogen low beam headlamp Module 60**

ECE-R149 Class DS	1TL 998 570-641
Right-hand traffic, ECE-R149 Class B	1BL 998 570-601
Left-hand traffic, ECE-R149 Class B	1ML 998 570-611

Dimensional sketches of the halogen low beam headlamp Module 60

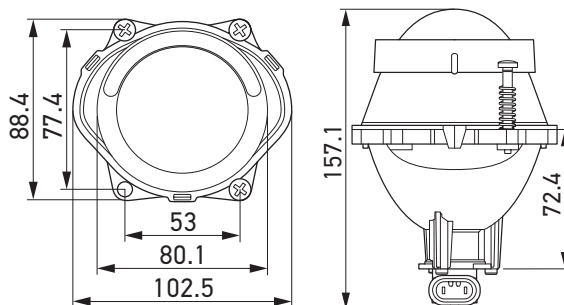



# HALOGEN

60 MM MODULES

# LOW BEAM AND HIGH BEAM

## SPECIFICATIONS

- It is easy to incorporate them into customer-specific design solutions thanks to their compact dimensions
- Excellent light output and homogeneous road illumination despite ultra-compact size
- Mounting via installation frame to allow adjustment from the front or rear
- Low weight
- With HB3 bulb

Halogen low and high beam headlamp Module 60



Halogen low beam headlamp Module 60



Halogen high beam headlamp Module 60



For further information on each product, see general overview on page 42



Photo: © BPR



### Halogen high beam headlamp Module 60

ECE-R149 Class B, SAE, without position light	1KL 998 570-621
ECE-R149 Class B, SAE, with position light	1KL 998 570-631

Dimensional sketches of the halogen high beam headlamp Module 60

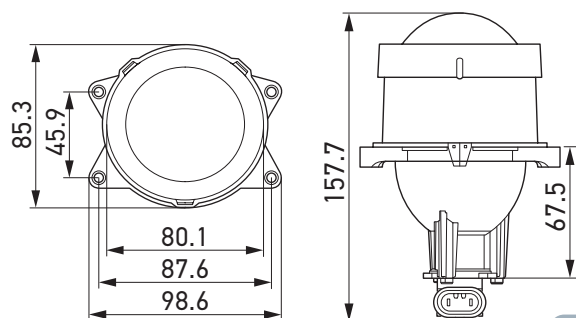





**LED low beam headlamp R 80\***

Right-hand traffic, ECE, DEUTSCH connector	<b>1B0 015 050-001</b>
Left-hand traffic, ECE, DEUTSCH connector	<b>1M0 015 050-011</b>
SAE, DEUTSCH connector	<b>1B0 015 050-031</b>
Right-hand traffic, ECE, FEP connector	<b>1B0 015 050-101</b>
Left-hand traffic, ECE, FEP connector	<b>1M0 015 050-111</b>
SAE, FEP connector	<b>1B0 015 050-131</b>



**LED high beam headlamp R 80\***

ECE, SAE, DEUTSCH connector	<b>1K0 015 050-021</b>
ECE, SAE, FEP connector	<b>1K0 015 050-121</b>

\* Mounting kit 9XX 254 163-001 not included in scope of supply.

LED

# 90 MM MODULES – ESSENTIAL LOW BEAM AND HIGH BEAM

## SPECIFICATIONS

- Specially developed reflector design for homogeneous illumination
- Compact and robust design
- Enables cost-effective switch from halogen to LED
- Optionally FEP or DEUTSCH connector



For further information on each product, see general overview on page 42

Dimensional sketches of the LED low and high beam headlamp R 80

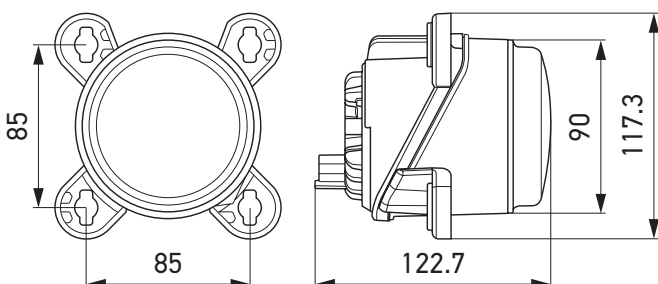

To the product video





## FAR EXCEEDING THE STANDARD

Are you interested in a customised lighting solution that is perfectly suited to your vehicle? Then we are the perfect partner for you.

Just get in touch with us. More information on p. 44.

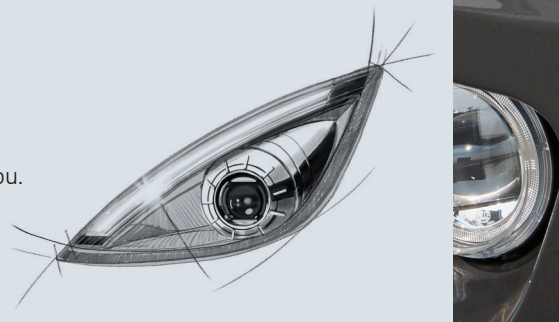

**LED low beam headlamp L 4060\***

Right-hand traffic, ECE, SAE, FEP connector	<b>1BL 012 488-001</b>
Left-hand traffic, ECE, FEP connector	<b>1ML 012 488-011</b>
Right-hand traffic, ECE, SAE, DEUTSCH connector	<b>1BL 012 488-101</b>
Left-hand traffic, ECE, DEUTSCH connector	<b>1ML 012 488-111</b>



**LED low beam headlamp L 4060 with daytime running / position light\***

Right-hand traffic, ECE, SAE, FEP connector	<b>1BL 012 488-021</b>
Left-hand traffic, ECE, FEP connector	<b>1ML 012 488-031</b>
Right-hand traffic, ECE, SAE, DEUTSCH connector	<b>1BL 012 488-121</b>
Left-hand traffic, ECE, DEUTSCH connector	<b>1ML 012 488-131</b>
Right-hand traffic, ECE, FEP connector, with fording ability**	<b>1BL 012 488-041</b>

\* Mounting kit 9XX 254 163-027 and 9XX 254 163-001 included in scope of supply.

\*\* More information on p. 46.

LED

## 90 MM MODULES – PERFORMANCE LOW BEAM

### SPECIFICATIONS

- Homogeneous high-end illumination similar to daylight thanks to innovative LED technology
- Low beam, daytime running light and position light in one module or as a separate low beam
- Simple conversion from halogen to LED possible
- Optionally FEP or DEUTSCH connector
- Individual front design thanks to modular design of the 90 mm series

Photo: © VDL Bus & Coach by VG

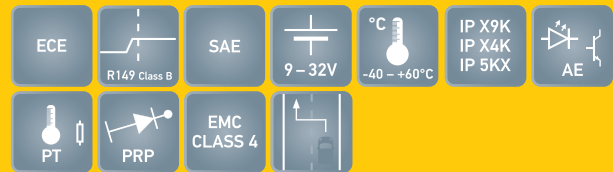

For further information on each product, see general overview on page 42

Dimensional sketches of the LED low beam headlamp L 4060

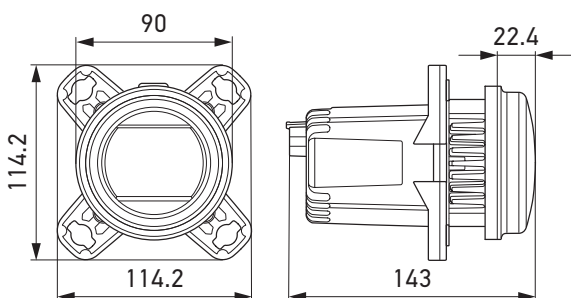





## DID YOU KNOW?

Malfunctions of the high beam (HB) with direction indicator (DI) module can usually be detected using the vehicle control unit. The stages of detection are as follows: DI: < 400 mA // HB: < 800 mA

If your control unit cannot detect stage < 400 mA for DI, the pulse generator will increase the current in an interval of 100 to 120 ms to simulate the level consistent with a standard 12 V (21 W) bulb.



**LED high beam headlamp L 4060**

With pre-assembled carrier frame	<b>1F0 011 988-021</b>
Without carrier frame	<b>1F0 011 988-121*</b>



**LED high beam headlamp L 4060  
with daytime running / position light**

With pre-assembled carrier frame	<b>1F0 011 988-031</b>
Without carrier frame	<b>1F0 011 988-131*</b>

\* Mounting kit 9XX 254 163-001 and 9XX 254 163-027 included in scope of supply.

\*\* More information on p. 46.

LED

# 90 MM MODULES – PERFORMANCE HIGH BEAM

## SPECIFICATIONS

- High-end illumination thanks to innovative LED technology
- High beam, daytime running and position light in one module, high beam and direction indicator light combination or high beam as a separate module
- Simple conversion from halogen to LED possible
- Robust die-cast aluminium housing with integrated driver electronics and FEP connector
- Individual front design thanks to modular design of the 90 mm series

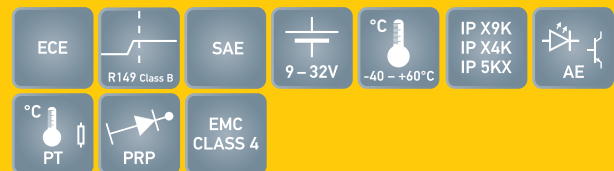

For further information on each product, see general overview on page 42



### LED high beam headlamp L 4060 with direction indicator light

With pulse generator and pre-assembled carrier frame	1F0 011 988-081
With pulse generator, without carrier frame	1F0 011 988-181*
Without pulse generator, with pre-assembled carrier frame	1F0 011 988-071
Without pulse generator, without carrier frame	1F0 011 988-171*
With pulse generator, without carrier frame, with fording ability**	1F0 011 988-191*

Dimensional sketches of the LED high beam headlamp L 4060

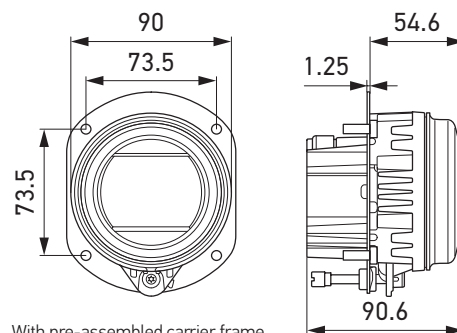

With pre-assembled carrier frame

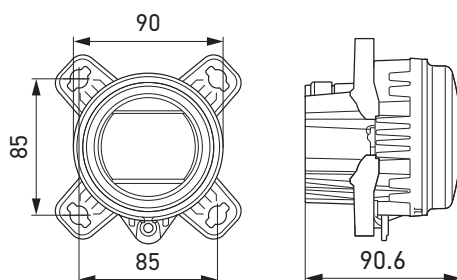

Without carrier frame





**LED fog lamp L 4060**

Without daytime running/position light	1N0 011 988-001
With daytime running/position light	1N0 011 988-011

Dimensional sketches of the LED fog lamp L 4060

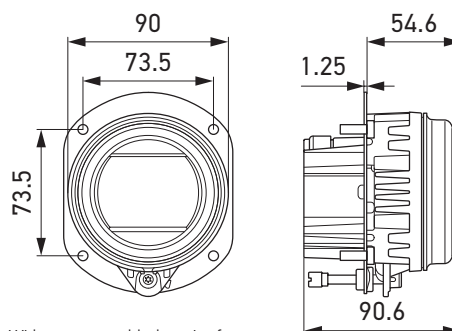

With pre-assembled carrier frame



**LED**

# 90 MM MODULES – PERFORMANCE FOG LIGHT

## SPECIFICATIONS

- Homogeneous illumination, similar to daylight
- Fog light in various combinations or as a separate module, with daytime running light, position light and cornering light.
- Simple conversion from halogen to LED possible
- Robust die-cast aluminium housing with integrated driver electronics and FEP connector
- Weight saving thanks to polycarbonate lens
- Individual front design thanks to modular design of the 90 mm series
- With pre-assembled carrier frame

Photo: © RAPIDO Reisemobile

ECE R149 Class B	SAE 9-32V	°C -40 - +60°C	IP X9K IP X4K IP 5KX	AE
°C PT	PRP	EMC CLASS 4		

For further information on each product, see general overview on page 42



### LED fog lamp L 4060 with cornering light

Left headlamp	1N0 011 988-051
Right headlamp	1N0 011 988-061

Dimensional sketches of the LED fog lamp L 4060 with cornering light

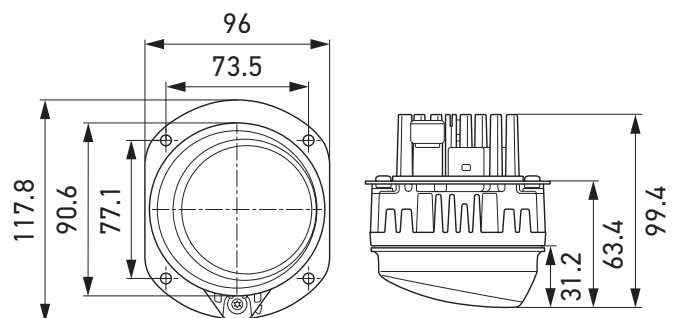

With pre-assembled carrier frame





To the product video

**Bi-LED low beam and high beam headlamp L 4565 - Essential\***

Right-hand traffic, ECE	1AL 015 318-001
Right-hand traffic, ECE, with pre-assembled mounting kit	1AL 015 318-111
Left-hand traffic, ECE	1LL 015 318-011
Left-hand traffic, ECE, with pre-assembled mounting kit	1LL 015 318-131
SAE	1AL 015 318-021
SAE, with pre-assembled mounting kit	1AL 015 318-151

\* Mounting kit 9XX 236 655-011 included in scope of supply.

Dimensional sketches of the Bi-LED low beam and high beam headlamp L 4565 - Essential

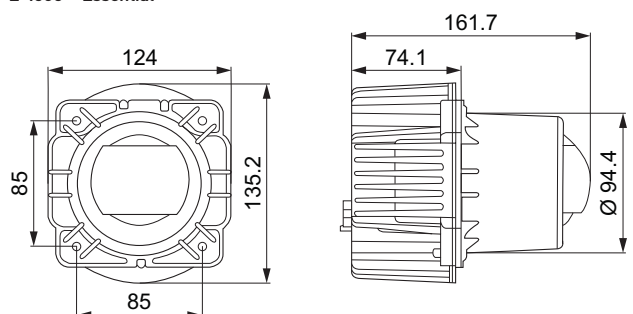

**BI-LED**

90 MM MODULES – ESSENTIAL AND PERFORMANCE

# LOW BEAM AND HIGH BEAM

## SPECIFICATIONS

- Excellent low beam and high beam from one single headlamp module
- Design freedom thanks to a modular system
- For the most diverse applications and the highest demands
- With 4-pin DEUTSCH connector
- Performance version with special features:
  - "Zero Tolerance Integration" for new design freedoms (see video)
  - 4 additional LEDs for even stronger light performance
  - Advanced light electronics

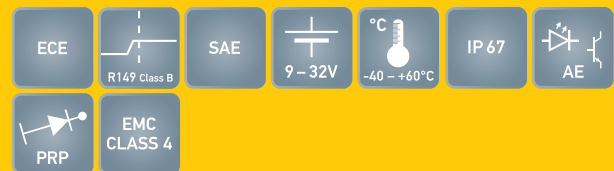
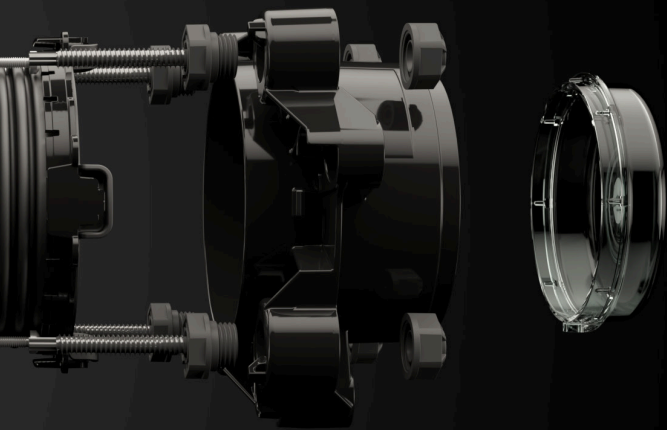

For further information on each product, see general overview on page 42



To the product video

Dimensional sketches of the Bi-LED low beam and high beam headlamp L 4565 – Performance

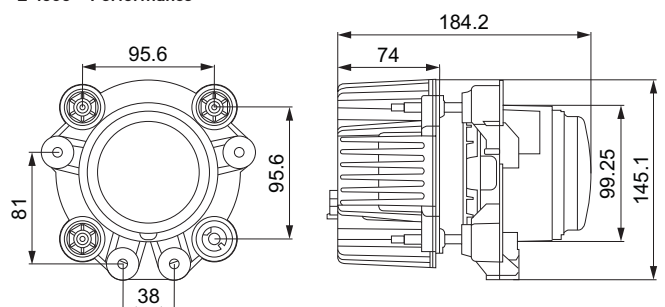

### Bi-LED low beam and high beam headlamp L 4565 – Performance\*

Right-hand traffic, ECE	1AL 015 318-031
Left-hand traffic, ECE	1LL 015 318-041
SAE	1AL 015 318-051





Dimensional sketches of the halogen low beam headlamp

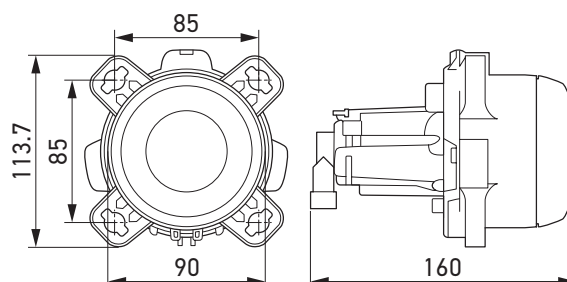

#### Halogen low beam headlamp

12 V, right-hand traffic, for Performance mounting	1BL 247 042-007*
12 V, left-hand traffic, for Performance mounting	1ML 247 042-027*
12 V, right-hand traffic, for Premium mounting	1BL 247 042-177**
12 V, left-hand traffic, for Premium mounting	1ML 247 042-187**
24 V, right-hand traffic, for Premium mounting	1BL 247 042-197**
24 V, left-hand traffic, for Premium mounting	1ML 247 042-207**





**HALOGEN**

Photo: © MAN Truck & Bus AG

90 MM MODULES – PERFORMANCE

# LOW BEAM AND HIGH BEAM

## SPECIFICATIONS

- Optimised light output and homogeneous illumination with little scattered light
- Low beam with 50 mm DE lens, high beam with free-form reflector
- Water-protected standard plug-in system for bulbs
- With H1 bulb



For further information on each product, see general overview on page 43



### Halogen high beam headlamp

12 V, with position light, for Performance mounting	1K0 247 043-007*
12 V, without position light, for Performance mounting	1K0 247 043-017*
12 V, with position light, for Premium mounting	1K0 247 043-117**
12 V, without position light, for Premium mounting	1K0 247 043-127**
24 V, with position light, for Premium mounting	1K0 247 043-137**
24 V, without position light, for Premium mounting	1K0 247 043-147**

- \* Mounting kit 9XX 254 163-001 included in scope of supply.
- \*\* Mounting kit 9XX 254 163-027 included in scope of supply.

Dimensional sketches of the halogen high beam headlamp

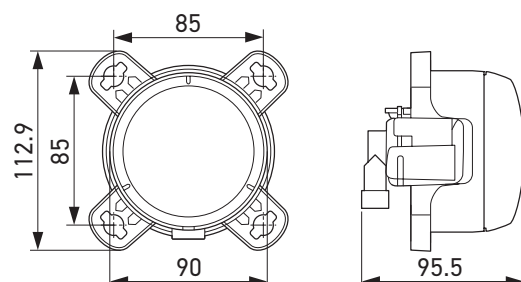





#### Bi-halogen low beam and high beam headlamp

12 V, H7, right-hand traffic, ECE	1AL 009 998-001*
12V, H7, left-hand traffic, ECE	1LL 009 998-011*
12V, H9, SAE	1AL 009 998-021**
24 V, H7, right-hand traffic, ECE	1AL 009 998-041***
24 V, H7, left-hand traffic, ECE	1LL 009 998-051***
24 V, H7, right-hand traffic, ECE, with fording ability ****	1AL 009 998-201*
24 V, H7, left-hand traffic, ECE, with fording ability ****	1LL 009 998-221*

\* Mounting kit 9XX 202 748-001 included in scope of supply.

\*\* Mounting kit 9XX 169 098-017 included in scope of supply.

\*\*\* Mounting kit 9XX 169 098-007 included in scope of supply.

\*\*\*\* More information on p. 46.



# BI-HALOGEN

90 MM MODULES – PERFORMANCE

## LOW BEAM AND HIGH BEAM

### SPECIFICATIONS

- Excellent light output and homogeneous illumination with little scattered light thanks to non-patterned 70 mm lens
- Low beam and high beam from one single headlamp module
- Unpatterned and hardened glass cover lens for a direct view of the lens
- High-quality aluminium reflector
- Pre-assembled adjusting screws for easy assembly
- Activation of low beam and high beam with integrated shutter technology

ECE



SAE



IP 5K4K

For further information on each product, see general overview on page 43

Dimensional sketches of the Bi-halogen low beam and high beam headlamp

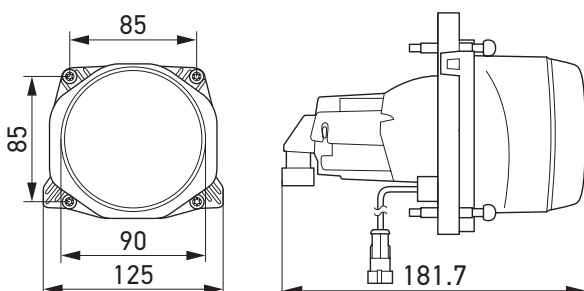





Dimensional sketches of the Bi-LED low beam and high beam headlamp M133 LED (R149 Class DS)

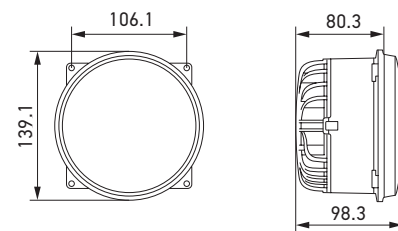

Flush mounting version

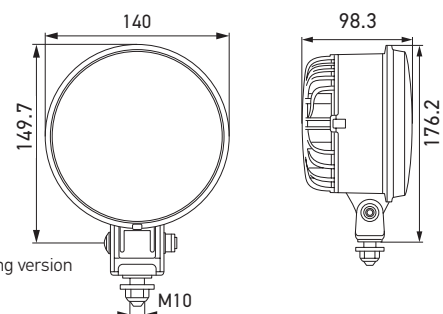

Surface mounting version

**Bi-LED low beam and high beam headlamp M133 LED  
R149 Class DS**

Simultaneous*, ECE, SAE, for integration	1S3 996 362-101
Independent**, ECE, for integration	1S3 996 362-111
Simultaneous* with position light, ECE, SAE, for integration	1S3 996 362-001
Independent** with position light, ECE, for integration	1S3 996 362-011
Simultaneous*, ECE, SAE, for surface mounting	1S3 996 362-301
Independent**, ECE, for surface mounting	1S3 996 362-311
Simultaneous* with position light, ECE, SAE, for surface mounting	1S3 996 362-201
Independent** with position light, ECE, for surface mounting	1S3 996 362-211

\* Simultaneous control: High beam can only be switched in combination with low beam. Low beam can also be switched on independently. Position light can be switched on at any time.



# BI-LED

133 MM MODULES

# LOW BEAM AND HIGH BEAM

## SPECIFICATIONS

- LED headlamp for easy conversion from halogen to LED
- Low beam, high beam and position light in one single headlamp
- Available as flush mounting and surface mounting version
- Robust die-cast aluminium housing
- With 4-pin DEUTSCH connector



For further information on each product, see general overview on page 43



Photo: © SAME DEUTZ-FAHR Deutschland GmbH



**Bi-LED low beam and high beam headlamp M133 LED  
R149 Class B**

Independent**, right-hand traffic, ECE, left with carrier frame	1A3 997 362-037
Independent**, right-hand traffic, ECE, right, with carrier frame	1A3 997 362-047
Independent**, left-hand traffic, ECE, left, with carrier frame	1L3 997 362-057***
Independent**, left-hand traffic, ECE, right, with carrier frame	1L3 997 362-067***
Independent**, left, SAE, with carrier frame	1A3 997 362-077***
Independent**, right, SAE, with carrier frame	1A3 997 362-087***
Independent**, right-hand traffic, ECE, without carrier frame	9DW 333 223-011***
Independent**, left-hand traffic, ECE, without carrier frame	9DW 333 223-021***
Independent**, SAE, without carrier frame	9DW 333 223-031***

**Dimensional sketches of the Bi-LED low beam and high beam headlamp M133 LED  
(R149 Class B)**

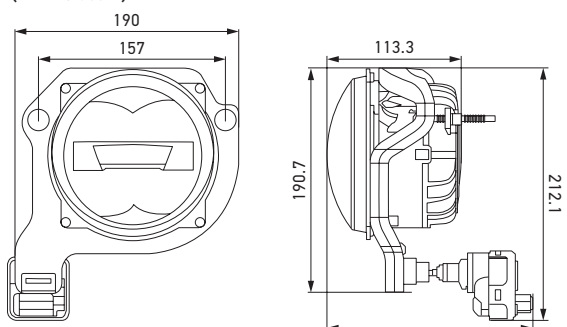

With pre-assembled carrier frame

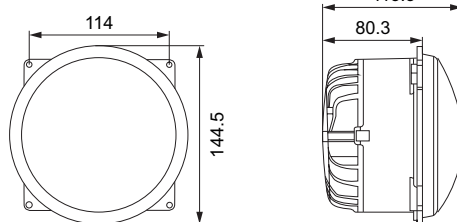

Without carrier frame

\*\* Independent control: Low beam and high beam can only be switched separately. Position light can be switched on at any time. \*\*\* Available 2021.





**Bi-halogen low beam and high beam headlamp M133  
R149 Class DS**

H4, ECE, SAE, for integration, with position light	153 996 262-037
H4, ECE, SAE, for integration, with position light, pre-assembled carrier frame	153 996 262-097

Dimensional sketches of the Bi-halogen low beam and high beam headlamp M133 (R149 Class DS)

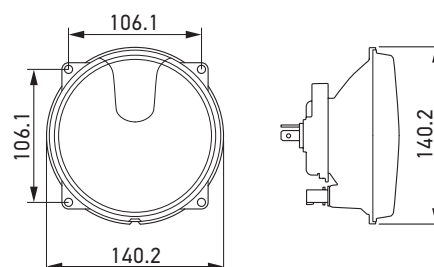

# BI-HALOGEN

133 MM MODULES

# LOW BEAM AND HIGH BEAM

## SPECIFICATIONS

- Low beam and high beam in one headlamp
- Low weight
- Classic, compact design



For further information on each product, see general overview on page 43



Photo: © e.GO Mobile AG



**Bi-halogen low beam and high beam headlamp M133  
R149 Class B**

H19, right-hand traffic, ECE, left, with carrier frame	<b>1A3 997 262-037</b>
H19, right-hand traffic, ECE, right, with carrier frame	<b>1A3 997 262-047</b>
H19, right-hand traffic, ECE, without carrier frame	<b>9DS 235 366-001</b>

**Dimensional sketches of the Bi-halogen low beam and high beam headlamp M133  
(R149 Class B)**

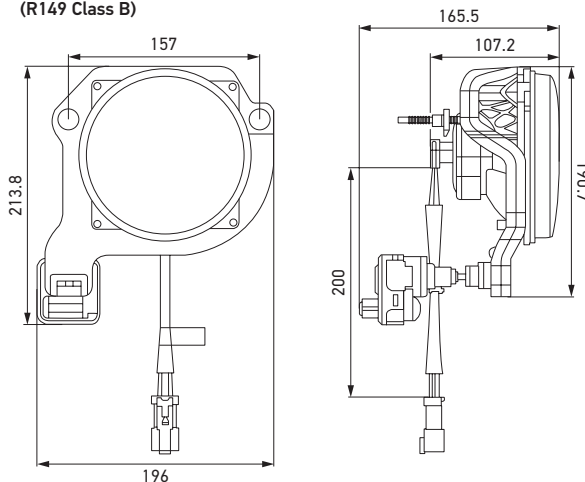

With pre-assembled carrier frame

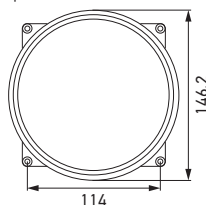

Without carrier frame

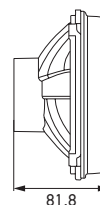



# 90 MM MODULE LIGHT DISTRIBUTIONS

## Low beam comparison

**LED Performance L 4060**  
(012 488)

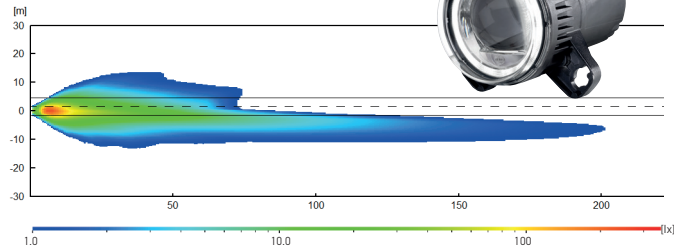

**Halogen Performance**  
(247 042)

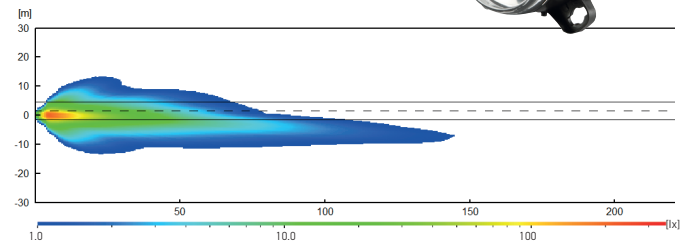

**LED Essential R 80**  
(015 050)

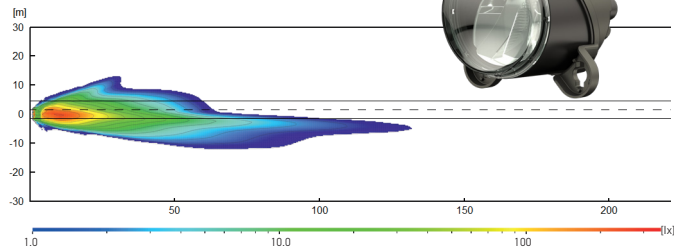

**Bi-LED Performance L 4565**  
(015 318)

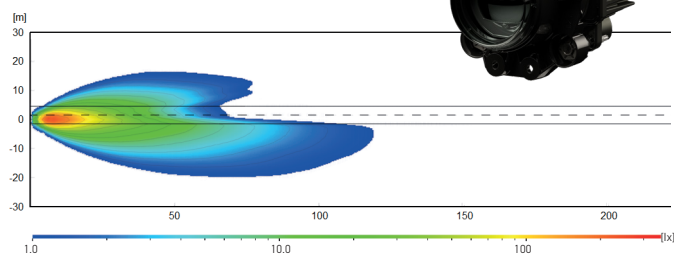

**Bi-halogen Performance**  
(009 998)

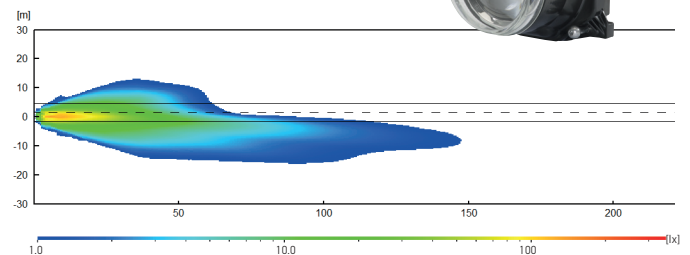

**Bi-LED Essential L 4565**  
(015 318)

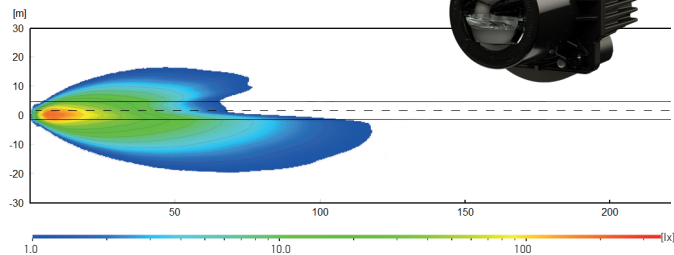

**Legend for isolux diagram (1 – 350 Lux)**

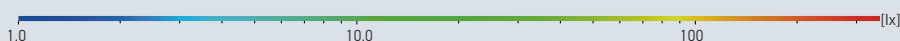

**Remarks**

Mounting height of the headlamps: 0.65 m  
Distance between the headlamps: 1.20 m

# 90 MM MODULE LIGHT DISTRIBUTIONS

## High beam comparison\*

**LED Performance L 4060**  
(011 988 + 012 488)

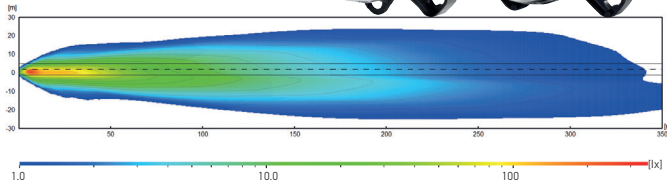

**Halogen Performance**  
(247 043 + 247 042)

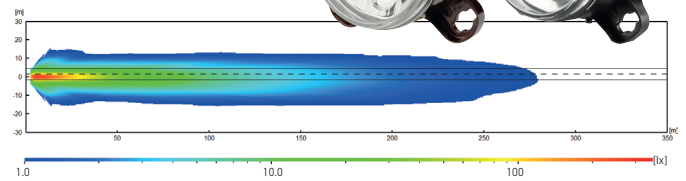

**LED Essential R 80**  
(015 050 + 015 050)

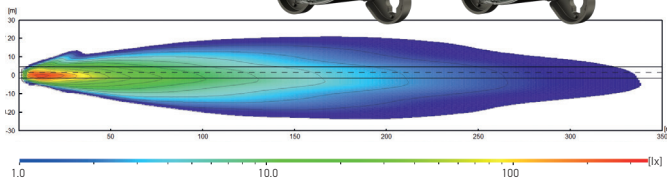

**Bi-LED Performance L 4565**  
(015 318)

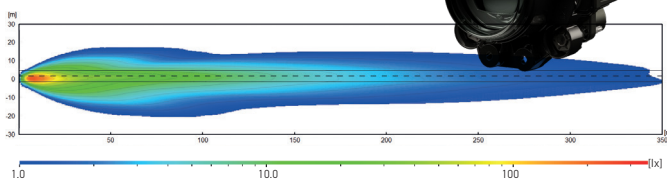

**Bi-halogen Performance**  
(009 998)

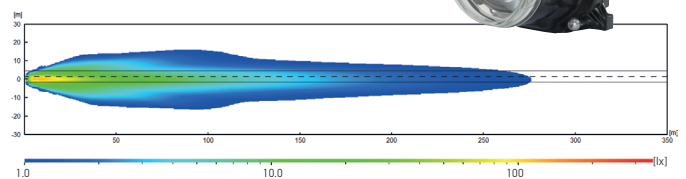

**Bi-LED Essential L 4565**  
(015 318)

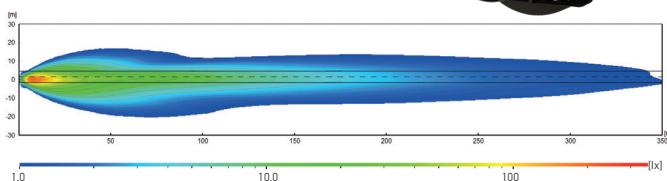

**\*Please note:**

Representation of high beam including low beam, as high beam is supplemented by low beam during driving.  
Bi-light distributions are generated when low beam is switched on and are only available as a bi-version.



# 60 MM MODULE LIGHT DISTRIBUTIONS

## Low beam comparison

Module 60 LED (R149 Class DS)  
(998 670)

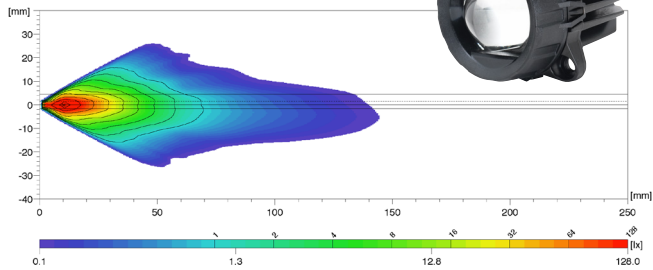

Module 60 Halogen (R149 Class DS)  
(998 570)

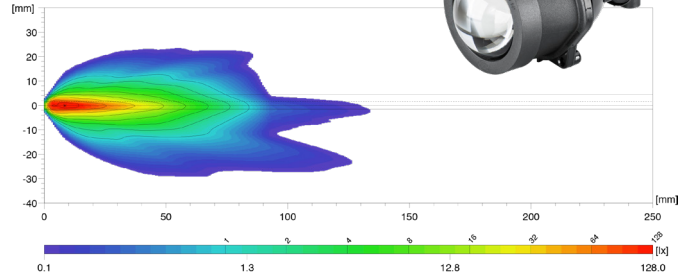

## High beam comparison

Module 60 LED (R149 Class DS)  
(998 670)

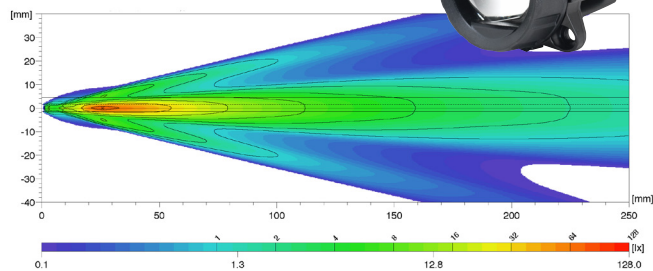

Module 60 Halogen (R149 Class DS)  
(998 570)

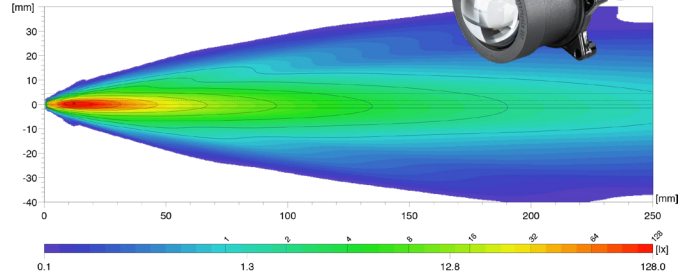

# 133 MM MODULES LIGHT DISTRIBUTIONS (R149 CL. DS)

## Low beam comparison

M133 LED (R149 Class DS)  
(996 362)

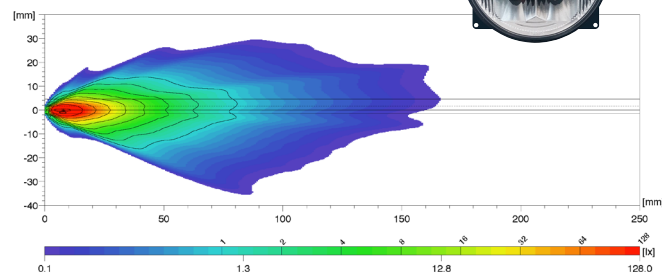

M133 Halogen (R149 Class DS)  
(996 262)

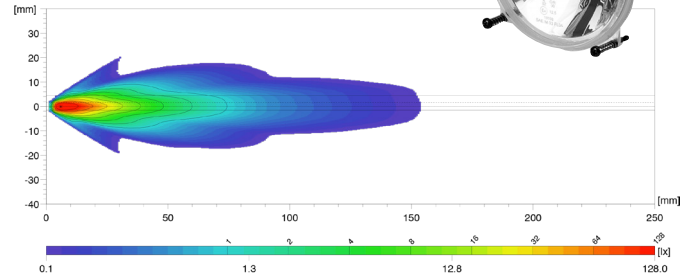

Simultaneous and separate switching

### Legend, isolux diagram (0.1 – 128 Lux)

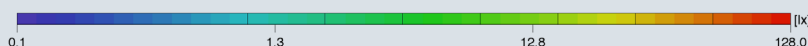

### Remarks

Mounting height of the headlamps: 0.65 m  
Distance between the headlamps: 1.20 m

# 133 MM MODULES LIGHT DISTRIBUTIONS (R149 CL. DS)

## High beam comparison

M133 LED (R149 Class DS)  
(996 362)

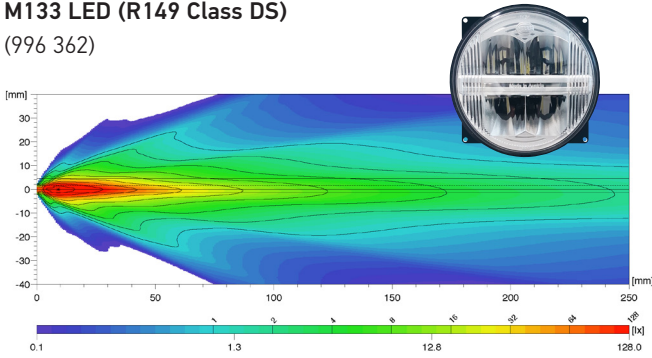

Simultaneous switching – representation of high beam including low beam

M133 Halogen (R149 Class DS)  
(996 262)

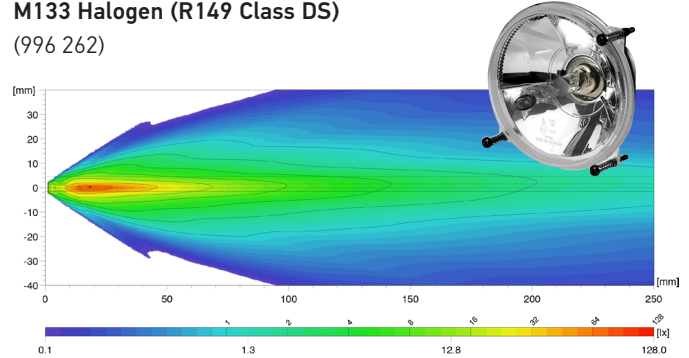

# 133 MM MODULES LIGHT DISTRIBUTIONS (R149 CL. B)

## Low beam comparison

M133 LED (R149 Class B)  
(997 362)

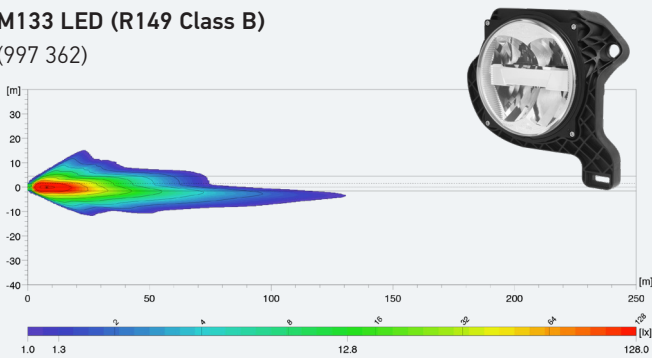

Independent switching

M133 Halogen (R149 Class B)  
(997 262)

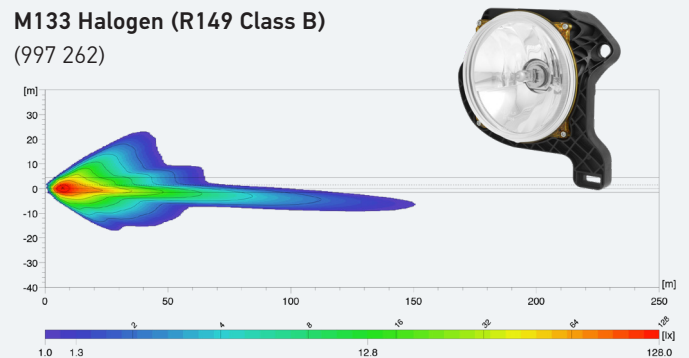

## High beam comparison

M133 LED (R149 Class B)  
(997 362)

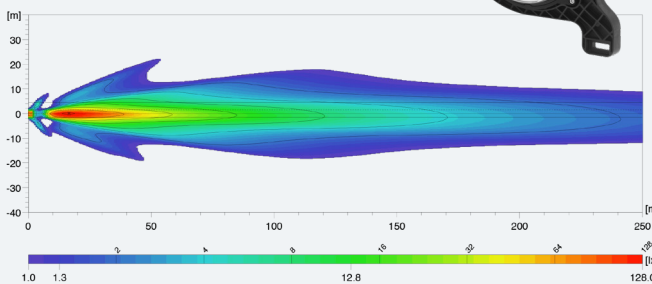

Simultaneous switching – representation of high beam including low beam

M133 Halogen (R149 Class B)  
(997 262)

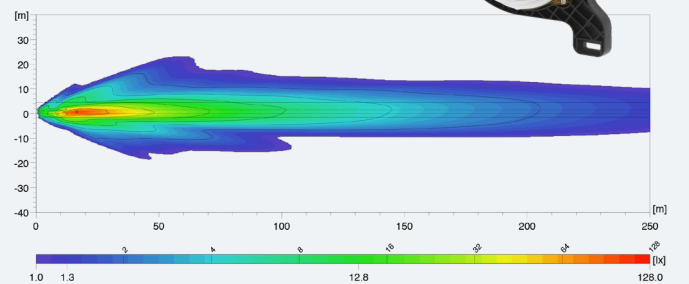

### Legend, isolux diagram (1.0 – 128 Lux)









### Remarks

Mounting height of the headlamps: 0.65 m  
Distance between the headlamps: 1.20 m

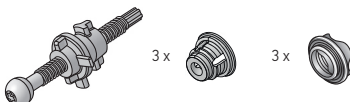
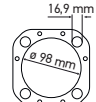
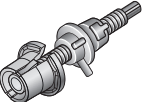
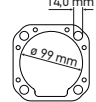
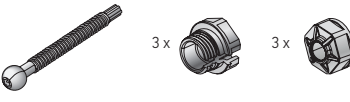
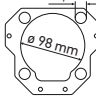
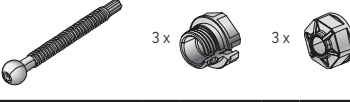

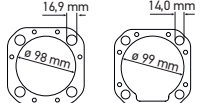
# FOR THE 90 MM MODULE

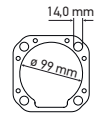
## Mounting kits

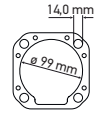
Part number	Product image	PU	Fastening concept	Holder
9XX 254 163-001	3 x 	1 piece	Performance	
9XX 254 163-027	3 x 	200 pieces	Premium	
9XX 236 655-011	3 x 	200 pieces	Heavy Duty	
9XX 236 655-011	3 x 	200 pieces	Heavy Duty	No carrier frame required
9XX 202 748-001	3 x 	1 piece	Premium + Performance	
9XX 169 098-017	3 x  2 x  Locking element for SAE version	100 pieces	Premium	
9XX 169 098-007	3 x 	200 pieces	Premium	

# Installation examples

### Important note:

The relevant country-specific statutory specifications and regulations for motor vehicles must be observed when installing headlamps!

### Installation example 1

Without carrier frame

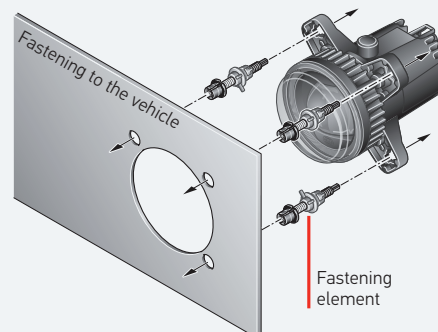

Centre-to-centre distance	Hole diameter	Panel thickness	Bracket part number	Module series
85 x 85	16.9 mm	3 mm	9AH 254 288-012	247 042 247 043 012 488 011 988 015 050
85 x 85	14 mm	3 mm	9AH 169 580-011	247 042 247 043 012 488 011 988
85 x 85	16.9 mm	3 mm	9AH 185 978-011	015 318 (Essential)
				015 318 (Performance)
85 x 85	16.9 mm + 14 mm	3 mm	9AH 254 288-012 9AH 169 580-011	009 998
85 x 85	14 mm	3 mm	9AH 169 580-011	009 998
85 x 85	14 mm	3 mm	9AH 169 580-011	009.998

**Installation example 2**  
With pre-assembled carrier frame

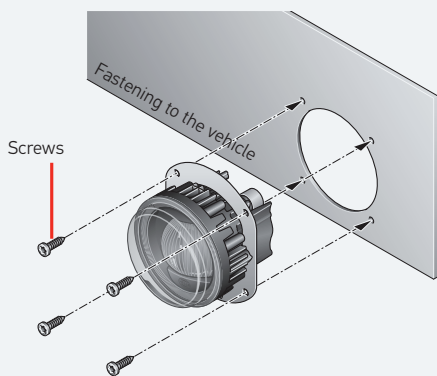

**Installation example 3**  
With additional carrier frame

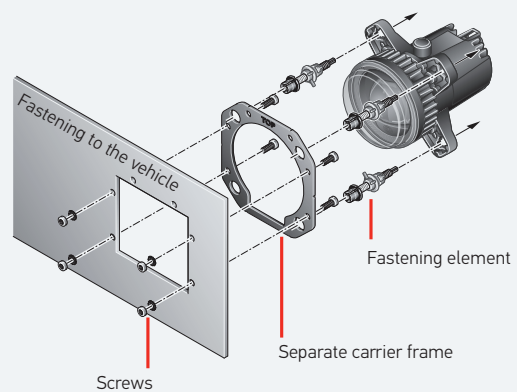



# USING THE EXAMPLE OF MODULE L 4565 ESSENTIAL

## Installation story

### NOTES ON MOUNTING

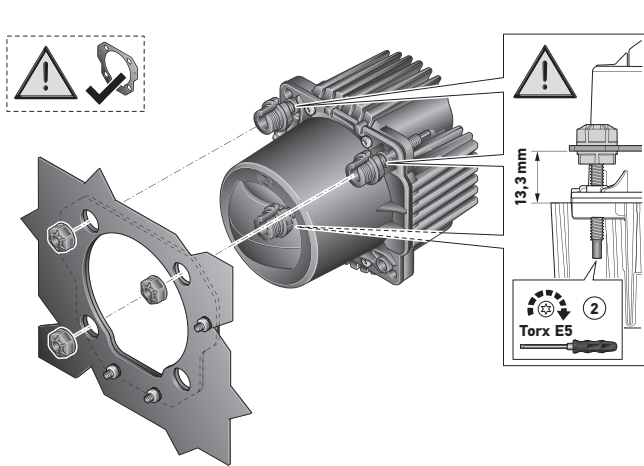

#### Integration on the vehicle with carrier frame

The HELLA carrier frame helps to mount the module correctly on the vehicle body.

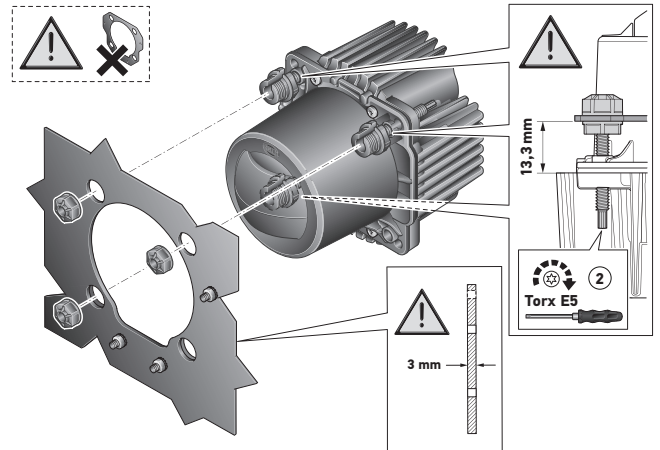

#### Integration on the vehicle without carrier frame

If no carrier frame is used and the module is mounted directly onto the vehicle body, a wall thickness of 3 mm must be observed.

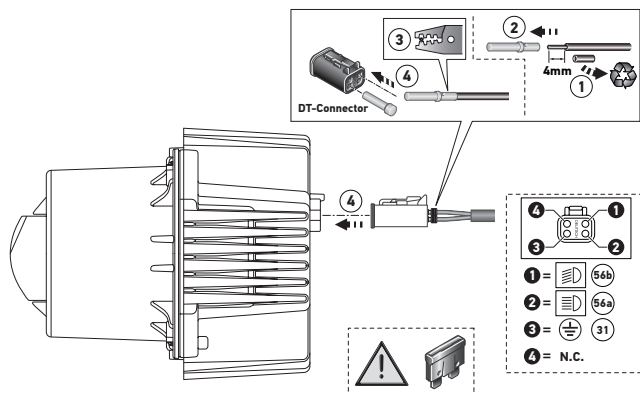

#### Electrical connection

For the electrical connection of the module, a sealed connector is required that fits the plug connection.

# GENERAL INFORMATION TO OBSERVE

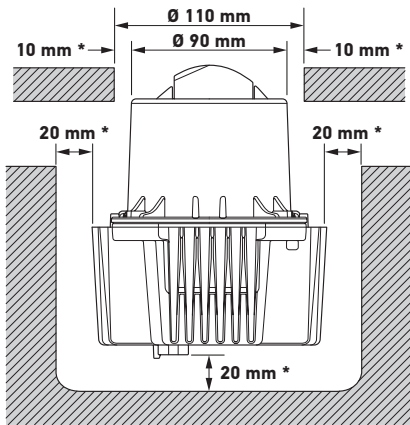

## Ventilation installation space\* and adjustment way

The minimum ventilation installation space must be ensured. This means that the dimensions around the module must be adhered to in order to ensure optimum heat dissipation. Furthermore, there must be sufficient space for adjusting the module.

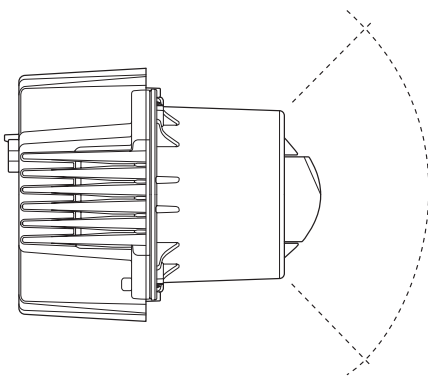

## Compliance with legal visibility angles

When installing the module, the legal visibility angles must be observed so that the light cone or light output is not impaired.

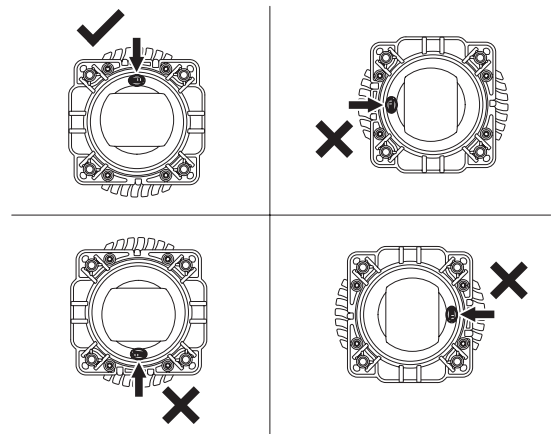

## Aligning the module

The module is correctly aligned when the HELLA logo is legible.

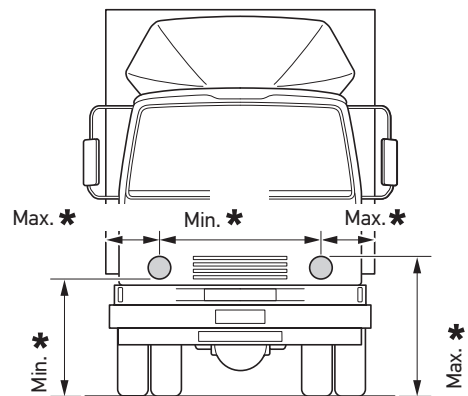

## Legal regulations

The relevant country-specific statutory specifications and regulations for motor vehicles must be observed when installing headlamps.





				90 mm modules LED – Essential				90 mm modules Halogen – Performance				133 mm modules LED	133 mm modules halogen			
Low beam and high beam (Bi-LED) 015 318-031 / -041	Low beam and high beam (Bi-LED) 015 318-051	Low beam and high beam (Bi-LED) 015 318-001 / -111 / -011 / -131	Low beam and high beam (Bi-LED) 015 318-021 / -151	Low beam 015 050-001 / -011 / -031	Low beam 015 050-101 / -111 / -131	High beam 015 050-021	High beam 015 050-121	Low beam and high beam (Bi-halogen) 009 998-001 / -011	Low beam and high beam (Bi-halogen) 009 998-021	Low beam and high beam (Bi-halogen) 009 998-041 / -051 / -201 / -221	Low beam 247 042-007 / -027 / -177 / -187	Low beam 247 042-197 / -207	High beam and position light 247 043-007 / -117 / -137	High beam 247 043-017 / -127 / -147	Low beam and high beam (Bi-LED) 996-362 / 997-362	Low beam and high beam (Bi-halogen) 996-262 / 997-262
LED surplus supply: FEP connector, 2- or 4-pin																
					X		X									
					X		X									
					X		X									
					X		X									
LED surplus supply: DEUTSCH connector, 2- or 4-pin																
X	X	X	X												X	
X	X	X	X												X	
X	X	X	X												X	
X	X	X	X												X	
					X		X									
Halogen connector surplus supply																
								X		X	X	X	X	X		
									X							
													X			
								X	X	X						
								X	X	X						
								X	X	X						
M60																





# INSTALLATION EXAMPLE

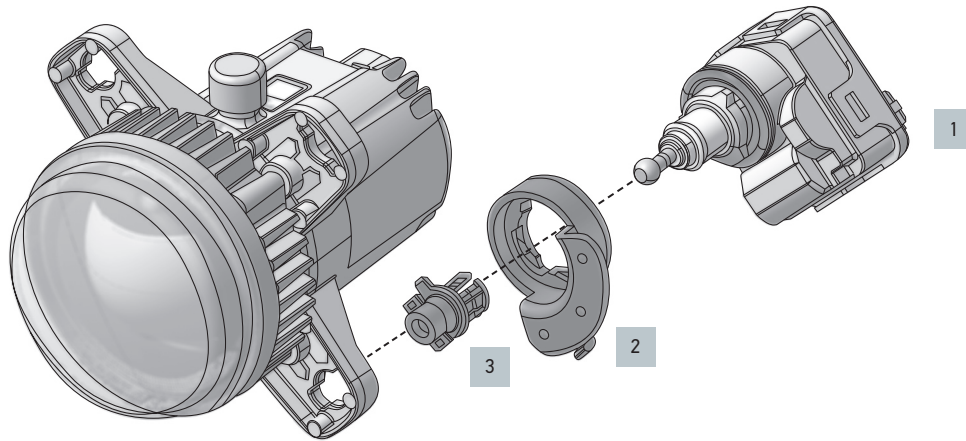

		90 mm modules LED – Essential						90 mm modules Halogen – Performance						133 mm modules LED	133 mm modules halogen	
Low beam and high beam (Bi-LED) 015 318-031 / -041	Low beam and high beam (Bi-LED) 015 318-051	Low beam and high beam (Bi-LED) 015 318-001 / -111 / -011 / -131	Low beam and high beam (Bi-LED) 015 318-021 / -151	Low beam 015 050-001 / -011 / -031	Low beam 015 050-101 / -111 / -131	High beam 015 050-021	High beam 015 050-121	Low beam and high beam (Bi-halogen) 009 998-001 / -011	Low beam and high beam (Bi-halogen) 009 998-021	Low beam and high beam (Bi-halogen) 009 998-041 / -051 / -201 / -221	Low beam 247 042-007 / -027 / -177 / -187	Low beam 247 042-197 / -207	High beam and position light 247 043-007 / -117 / -137	High beam 247 043-017 / -127 / -147	Low beam and high beam (Bi-LED) 996-362 / 997-362	Low beam and high beam (Bi-halogen) 996-262 / 997-262
Headlamp levelling systems, 12 V																
				X	X			X			X			X	X	
				X	X			X			X					
X		X														
Headlamp levelling systems, 24 V																
				X	X					X		X				
				X	X							X				
				X	X					X		X				
				X	X					X		X				
X		X														
Accessoires																
								X		X						



# OVERVIEW

# Type approvals

	Part number	Main light functions	Auxiliary light functions	Variant	Weight	Voltage	Light source	ECE test mark	Approval*		
									R149 Class B	R149 Class DS	SAE
60 mm modules LED	1TL 998 670-021	LB	-	-	278 g	12 V	LED	Ⓔ 0311		x	x
	1TL 998 670-041	LB	-	-	278 g	12 V	LED	Ⓔ 0311		x	x
	1KL 998 670-031	HB	-	-	278 g	12 V	LED	Ⓔ 0313		x	
	1KL 998 670-051	HB	-	-	278 g	12 V	LED	Ⓔ 0313		x	x
	1KL 998 670-017	HB	-	-	278 g	12 V	LED	Ⓔ 0536	x		
60 mm modules Halogen	1TL 998 570-641	LB	-	-	374 g	12 V	Halogen HB3	Ⓔ 0237		x	
	1BL 998 570-601	LB	-	ES	374 g	12 V	Halogen HB3	Ⓔ 0005	x		
	1ML 998 570-611	LB	-	LES	374 g	12 V	Halogen HB3	Ⓔ 0006	x		
	1KL 998 570-621	HB	-	-	338 g	12 V	Halogen HB3	Ⓔ 24910	x		x
	1KL 998 570-631	HB	PO	-	330 g	12 V	Halogen HB3	Ⓔ 26353	x		x
90 mm modules LED – Performance	1BL 012 488-001	LB	-	ES	763 g	Multi-voltage	LED	Ⓔ 3831	x		x
	1ML 012 488-011	LB	-	LES	763 g	Multi-voltage	LED	Ⓔ 4090	x		
	1BL 012 488-101	LB	-	ES	764 g	Multi-voltage	LED	Ⓔ 3881	x		x
	1ML 012 488-111	LB	-	LES	764 g	Multi-voltage	LED	Ⓔ 4090	x		
	1BL 012 488-021	LB	DRL / PO	ES	782 g	Multi-voltage	LED	Ⓔ 3831	x		x
	1ML 012 488-031	LB	DRL / PO	LES	780 g	Multi-voltage	LED	Ⓔ 4090	x		
	1BL 012 488-121	LB	DRL / PO	ES	783 g	Multi-voltage	LED	Ⓔ 3881	x		x
	1ML 012 488-131	LB	DRL / PO	LES	781 g	Multi-voltage	LED	Ⓔ 4090	x		
	1BL 012 488-041	LB	DRL / PO	ES	824 g	Multi-voltage	LED	Ⓔ 3831	x		x
	1FO 011 988-021	HB	-	-	519 g	Multi-voltage	LED	Ⓔ 3831	x		x
	1FO 011 988-121	HB	-	-	552 g	Multi-voltage	LED	Ⓔ 3831	x		x
	1FO 011 988-031	HB	DRL / PO	-	524 g	Multi-voltage	LED	Ⓔ 3831	x		x
	1FO 011 988-131	HB	DRL / PO	-	556 g	Multi-voltage	LED	Ⓔ 3831	x		x
	1FO 011 988-081	HB	DI	-	584 g	Multi-voltage	LED	Ⓔ 3831	x		x
	1FO 011 988-181	HB	DI	-	616 g	Multi-voltage	LED	Ⓔ 3831	x		x
	1FO 011 988-071	HB	DI	-	524 g	Multi-voltage	LED	Ⓔ 3831	x		x
	1FO 011 988-171	HB	DI	-	556 g	Multi-voltage	LED	Ⓔ 3831	x		x
	1FO 011 988-191	HB	DI	-	624 g	Multi-voltage	LED	Ⓔ 3831	x		x
	1NO 011 988-001	FL	-	-	521 g	Multi-voltage	LED	Ⓔ 3831	x		x
	1NO 011 988-011	FL	DRL / PO	-	527 g	Multi-voltage	LED	Ⓔ 3831	x		x
1NO 011 988-051	FL	CL L	-	516 g	Multi-voltage	LED	Ⓔ 3832	x		x	
1NO 011 988-061	FL	CL R	-	516 g	Multi-voltage	LED	Ⓔ 3832	x		x	
1AL 015 318-031	Bi	-	ES	1,366 g	Multi-voltage	LED	In progress	x			
1LL 015 318-041	Bi	-	LES	1,366 g	Multi-voltage	LED	In progress	x			
1AL 015 318-051	Bi	-	-	1,366 g	Multi-voltage	LED	-			x	
90 mm modules LED – Essential	1B0 015 050-001	LB	-	ES	445 g	Multi-voltage	LED	Ⓔ 0007	x		
	1M0 015 050-011	LB	-	LES	445 g	Multi-voltage	LED	Ⓔ 0008	x		
	1B0 015 050-101	LB	-	ES	445 g	Multi-voltage	LED	Ⓔ 0007	x		
	1M0 015 050-111	LB	-	LES	445 g	Multi-voltage	LED	Ⓔ 0008	x		
	1B0 015 050-031	LB	-	-	445 g	Multi-voltage	LED	-			x
	1B0 015 050-131	LB	-	-	445 g	Multi-voltage	LED	-			x
	1K0 015 050-021	HB	-	-	445 g	Multi-voltage	LED	Ⓔ 0009	x		x
	1K0 015 050-121	HB	-	-	445 g	Multi-voltage	LED	Ⓔ 0009	x		x
	1AL 015 318-001	Bi	-	ES	1,307 g	Multi-voltage	LED	Ⓔ 0014	x		
	1AL 015 318-111	Bi	-	ES	1,307 g	Multi-voltage	LED	Ⓔ 0014	x		
	1LL 015 318-011	Bi	-	LES	1,307 g	Multi-voltage	LED	Ⓔ 0015	x		
	1LL 015 318-131	Bi	-	LES	1,307 g	Multi-voltage	LED	Ⓔ 0015	x		
	1AL 015 318-021	Bi	-	-	1,307 g	Multi-voltage	LED	-			x
	1AL 015 318-151	Bi	-	-	1,307 g	Multi-voltage	LED	-			x

	Part number	Main light functions	Auxiliary light functions	Variant	Weight	Voltage	Light source	ECE test mark	Approval*		
									R149 Class B	R149 Class DS	SAE
90 mm modules Halogen – Performance	1AL 009 998-001	Bi	–	ES	783 g	12 V	Halogen H7	Ⓔ 2484	x		
	1LL 009 998-011	Bi	–	LES	820 g	12 V	Halogen H7	Ⓔ 2485	x		
	1AL 009 998-021	Bi	–	ES	794 g	12 V	Halogen H9	–			x
	1AL 009 998-041	Bi	–	ES	820 g	24 V	Halogen H7	Ⓔ 2484	x		
	1LL 009 998-051	Bi	–	LES	820 g	24 V	Halogen H7	Ⓔ 2485	x		
	1AL 009 998-201	Bi	–	ES	820 g	24 V	Halogen H7	Ⓔ 2484	x		
	1LL 009 998-221	Bi	–	LES	820 g	24 V	Halogen H7	Ⓔ 2485	x		
	1BL 247 042-007	LB	–	ES	513 g	12 V	Halogen H1	Ⓔ 2397	x		
	1ML 247 042-027	LB	–	LES	513 g	12 V	Halogen H1	Ⓔ 2398	x		
	1BL 247 042-177	LB	–	ES	513 g	12 V	Halogen H1	Ⓔ 2397	x		
	1ML 247 042-187	LB	–	LES	513 g	12 V	Halogen H1	Ⓔ 2398	x		
	1BL 247 042-197	LB	–	ES	513 g	24 V	Halogen H1	Ⓔ 2397	x		
	1ML 247 042-207	LB	–	LES	513 g	24 V	Halogen H1	Ⓔ 2398	x		
	1K0 247 043-007	HB	PO	–	360 g	12 V	Halogen H1	Ⓔ 2397	x		
	1K0 247 043-017	HB	–	–	335 g	12 V	Halogen H1	Ⓔ 2397	x		
	1K0 247 043-117	HB	PO	–	288 g	12 V	Halogen H1	Ⓔ 2397	x		
	1K0 247 043-127	HB	–	–	340 g	12 V	Halogen H1	Ⓔ 2397	x		
	1K0 247 043-137	HB	PO	–	288 g	24 V	Halogen H1	Ⓔ 2397	x		
1K0 247 043-147	HB	–	–	281 g	24 V	Halogen H1	Ⓔ 2397	x			
133 mm modules LED	1S3 996 362-001	Bi	PO	–	860 g	12 V	LED	Ⓔ 4989		x	x
	1S3 996 362-011	Bi	PO	–	860 g	12 V	LED	Ⓔ 4884		x	
	1S3 996 362-101	Bi	–	–	860 g	12 V	LED	Ⓔ 4989		x	x
	1S3 996 362-111	Bi	–	–	860 g	12 V	LED	Ⓔ 4884		x	
	1S3 996 362-201	Bi	PO	–	1,055 g	12 V	LED	Ⓔ 4989		x	x
	1S3 996 362-211	Bi	PO	–	1,055 g	12 V	LED	Ⓔ 4884		x	
	1S3 996 362-301	Bi	–	–	1,055 g	12 V	LED	Ⓔ 4989		x	x
	1S3 996 362-311	Bi	–	–	1,055 g	12 V	LED	Ⓔ 4884		x	
	1A3 997 362-037	Bi	–	ES	1,255 g	12 V	LED	Ⓔ 0053	x		
	1A3 997 362-047	Bi	–	ES	1,255 g	12 V	LED	Ⓔ 0053	x		
	1L3 997 362-057	Bi	–	LES	1,255 g	12 V	LED	In progress	x		
	1L3 997 362-067	Bi	–	LES	1,255 g	12 V	LED	In progress	x		
	1A3 997 362-077	Bi	–	–	1,255 g	12 V	LED	–			x
	1A3 997 362-087	Bi	–	–	1,255 g	12 V	LED	–			x
	9DW 333 223-011	Bi	–	ES	960 g	12 V	LED	In progress	x		
	9DW 333 223-021	Bi	–	LES	960 g	12 V	LED	In progress	x		
	9DW 333 223-031	Bi	–	–	960 g	12 V	LED	–			x
	133 mm modules Halogen	1S3 996 262-037	Bi	PO	–	323 g	12 V	Halogen H4	Ⓔ 15315		x
1S3 996 262-097		Bi	PO	–	376 g	12 V	Halogen H4	Ⓔ 15315		x	x
1A3 997 262-037		Bi	–	ES	695 g	12 V	Halogen H19	Ⓔ 5058	x		
1A3 997 262-047		Bi	–	ES	695 g	12 V	Halogen H19	Ⓔ 5058	x		
9DS 235 366-001		Bi	–	ES	329 g	12 V	Halogen H19	Ⓔ 5058	x		

LB: Low beam  
HB: High beam  
Bi: Low beam and high beam

PO: Position light  
DRL: Daytime running light  
DI: Direction indicator light

ES: Right-hand traffic  
LES: Left-hand traffic  
SAE: USA

FL: Fog light  
CL: Cornering light

\* More information about approvals and suitable vehicle classes is available on request.



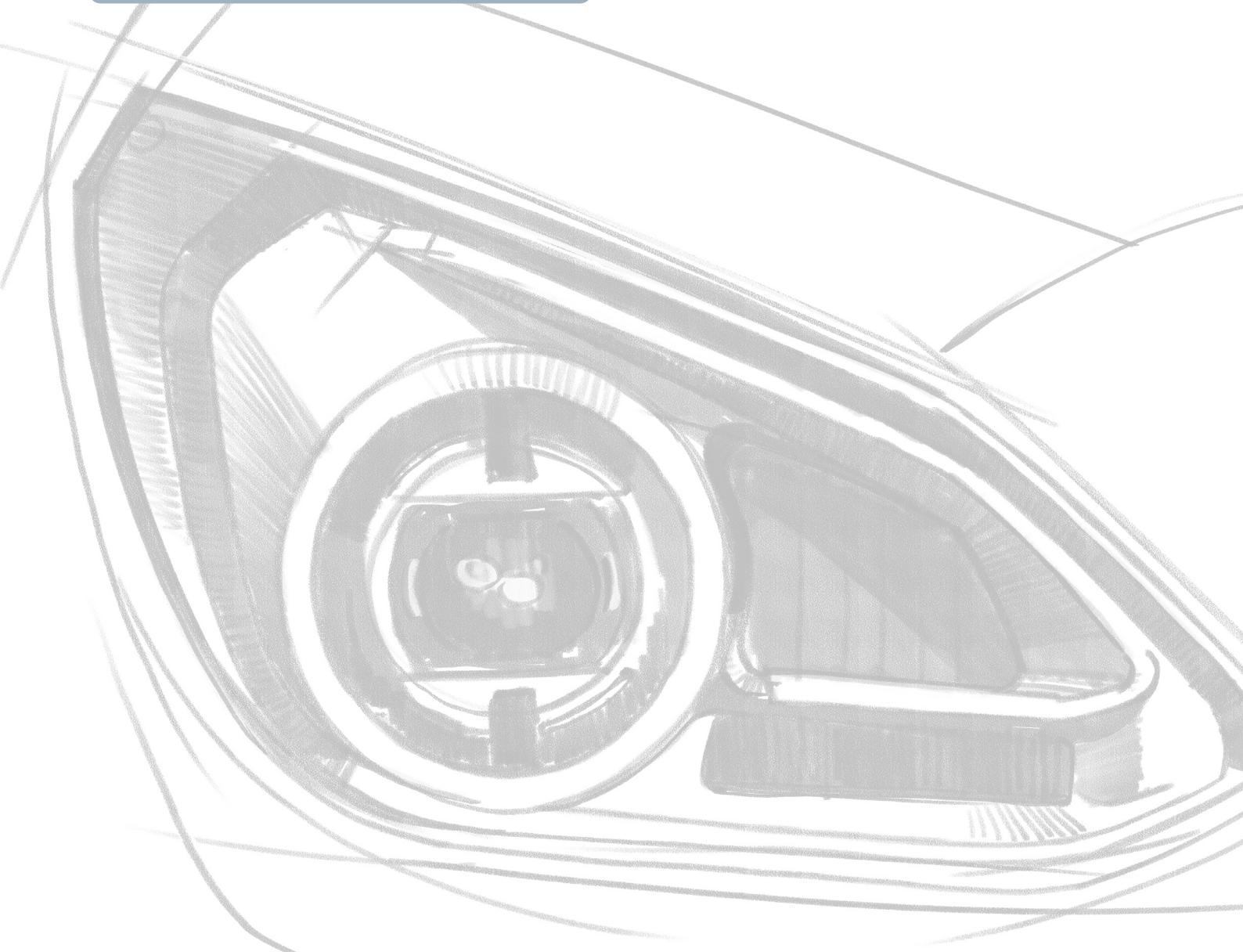

## BREAKING NEW GROUND WITH MODULARITY

# HELLA lends radiance to individual projects

**With high quality standards, HELLA creates special modular solutions for a wide range of applications.**

The outstanding light output is not only reserved for proven technologies, but also brings safety, reliability and radiance to unusual projects.

With lighting expertise and automotive know-how, HELLA is a reliable development partner for bringing the form and function of customised vehicle lighting to life. New standards can be set based on specific requirements. The styling and design options are just as strong as the potential for high-tech advancements.

**Development process based on individual needs – for maximum individuality**

Individual projects always light the way towards specifically developing and integrating existing modules of the right type, scope and performance. They provide a high level of individuality and innovation as well as a broad range of options. For example, customised headlamp housings can be fitted with existing HELLA modules from a large variety of modern headlamps from the product range. Whenever there are precise design specifications and strict technological requirements that have to fit in perfectly with the character of the vehicle, the order of the day is: Everything but standard.

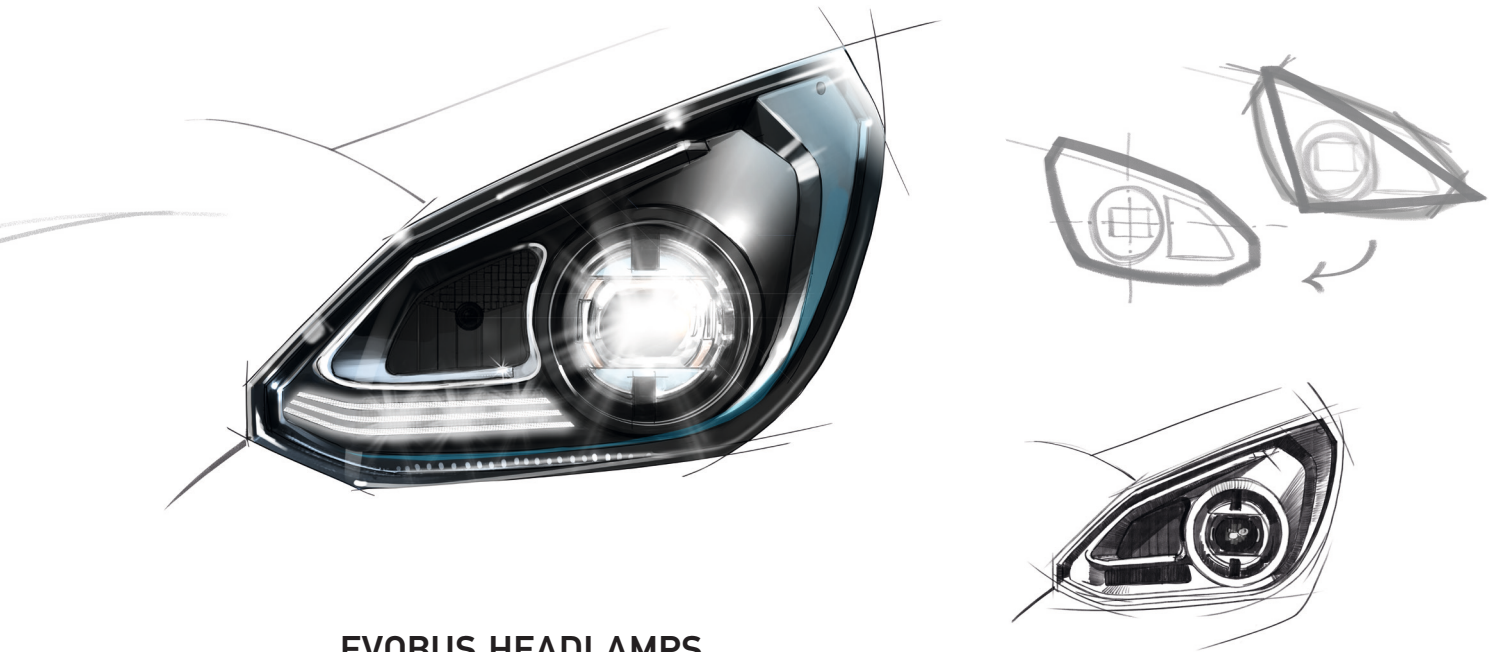

## EVOBUS HEADLAMPS

### A SYMMETRY OF DESIGN AND QUALITY.

Illuminating the way forward with a reassuring sense of safety, HELLA created a headlamp that combines timeless design and sophistication with superior quality. Clean lines and smooth angles complement each other perfectly while characterizing the distinctive design.



## STEYR HEADLAMPS

### FOR THE HIGHEST DEMANDS.

Adverse weather conditions, rough terrain, heavy transport. Vehicles that are regularly exposed to the highest of loads must work perfectly. HELLA is well aware of the challenges and works tirelessly to overcome these so that our lights continue to function even when far from the nearest road. With HELLA's advanced technology integrated into a custom-made headlamp we are able to increase driver productivity while projecting an exclusive design.



## FAQ

# Important information at a glance

→ **Do HELLA headlamps satisfy functional safety requirements?**

All HELLA low beam headlamps (and front direction indicators) have been developed in accordance with the ISO 26262 functional safety standard.

→ **Do I need a headlamp levelling system for low beam?**

This varies, depending on the vehicle. The decisive factor is the extent to which the light cone of the headlamp changes when the vehicle is loaded. If regulation is necessary, this can be controlled either manually using the rotary switch or automatically using inclination sensors. If, however, the low beam headlamp produces more than 2,000 lumens, control must always be automatic.

→ **Which headlamp levelling system can be used?**

Further information can be found on page 40 of this brochure.

→ **How many setting adjustments must be possible for a headlamp?**

If a headlamp levelling system is necessary, the extent of movement of the headlamp must cover the full range of the anticipated inclination of the vehicle.

→ **What characterises a product with fording ability?**

Lighting products with fording ability are used on vehicles that briefly drive through waterways, streams or rivers in off-road situations. Here the vehicle can be immersed in water up to the maximum fording depth (water depth) specified in each case, or the bow wave may briefly wash over the front of the vehicle up to the maximum fording depth. A suitably designed seal prevents headlamps with fording ability being damaged by water ingress up to a specified water pressure (e.g. up to 0.6 bar).

→ **Can the LED lamps be used with pulse duration modulation?**

Our LED modules have not been developed for pulse duration modulation. Please ask about our accessories here.

→ **How many lumens do the LED modules produce?**

All our LED modules have a lumen output of < 2,000 lumens so that no cleaning unit and an automatic headlamp levelling system is necessary.

→ **Can halogen modules be upgraded to LED?**

HELLA's LED modules are similar to the halogen modules in terms of physical structure so that they can be easily replaced or upgraded. However, consideration should be given to electronic modifications required due to the reduced power requirements of LED modules and fault monitoring by the vehicle lighting control system.

→ **What do the abbreviations R149 Class B and R149 Class DS mean?**

Due to ECE regulation updates, the older R112 and R113 regulations will no longer be valid in future. Instead, the R149 regulation is now the new standard for all ECE vehicle headlamps. All HELLA products in this catalogue are or are currently being updated to the latest version of the regulation. In order to optimally equip or retrofit a vehicle, the legal regulations must be observed. The specifications of ECE Regulation 48/86 include requirements for front lighting. Class B is required for most road vehicles. There are several other standards for light and slow-moving vehicles, with class DS being the most common. The most noticeable feature of Class DS is the symmetrical cut-off line for low beam (in contrast to Class B with a graduated cut-off line, which directs more light to the side of the vehicle and less towards oncoming traffic). The acceptance of the DS standard varies within the ECE regulatory area. Not all countries that follow the ECE regulations observe the provisions in every detail. There are some special extensions. We therefore recommend that every vehicle manufacturer checks all local requirements.

→ **What is the difference between DOT, SAE and ASABE?**

**ASABE:** The American Society of Agricultural and Biological Engineers. Among other things, it defines standards for agricultural vehicles.

**DOT:** The US Department of Transportation; headlamps that are designed, manufactured, tested and approved for US road use carry a DOT marking.

**SAE** (Society of Automotive Engineers) is the association of American automotive designers and engineers. Advocates for standards in the automotive industry, e.g. the standard for assembling and manufacturing components in the automotive sector.

## CONTACT

# HELLA worldwide – a global network

Contact persons, who would be pleased to answer any questions and offer assistance, are available at the addresses listed below.  
**We are looking forward to exciting, ground-breaking projects.**

## HEADQUARTER

### HELLA GmbH & Co. KGaA

Rixbecker Straße 75  
59557 Lippstadt,  
Deutschland

Phone: +49 2941 38-0  
info@hella.com  
www.hella.com

## AMERICAS

### HELLA, Inc.

201 Kelly Drive  
P.O. Box 2665  
Peachtree City,  
GA 30269 USA

Phone: +1 877 224-3552  
www.hellausa.com

## ASIA

### HELLA Trading (Shanghai) Co. Ltd.

11th/F, Block 5, Daning Hub No. 1898 Gong  
He Xin Road Shanghai 200072  
P. R. China

Phone: +86 21 6117-6228  
www.hellacn.com

### HELLA India Lighting Ltd.

6th Floor, Platinum  
Tower, Plot no. 184,  
Udyog Vihar Phase-1  
Gurgaon -122016

Phone: +91 124 4658600  
www.hella.co.in

## EUROPE

### HELLA Fahrzeugteile Austria GmbH

Handelskai 94–96  
1200 Wien, Österreich

Phone: +43 1 60689-20  
info-ag-ce@hella.at  
www.hella.com/agro

### HELLA Limited

Unit 6 Appletree  
Industrial Estate  
Chipping Warden  
Banbury,  
Oxon OX17 1LL,  
England, UK

Phone: +44 1295 662400  
hella.sales@hella.com  
www.hella.co.uk

### HELLA Benelux BV

Celsiusbaan 2,  
Postbus 1398  
3430 BJ Nieuwegein,  
Nederland

Phone: +31 30 6095611  
nl.info@hella.com  
www.hella.nl

### HELLA S.p.A.

Via B. Buozzi, 5  
20090 - Calepio di Settala,  
Italia

Phone: +39 2 98835-1  
infoitalia@hella.com  
www.hella.it

### HELLA S.A.S.

11, avenue Albert Einstein  
93150 Le Blanc Mesnil  
France

Phone: +33 149 395959  
www.hella.fr  
info.fr@hella.com

## AUSTRALIA AND OCEANIA

### HELLA Australia Pty Ltd

4 Hargrave Place  
Mentone, VIC, 3194, AUSTRALIA  
P.O. Box 89, Mentone, VIC, 3194  
Australia

Phone: +61 1800 061 729  
info.au@hella.com  
www.hella.com.au

### HELLA - New Zealand Limited

81 - 83 Ben Lomond Crescent  
Pakuranga, Auckland  
PO Box 51-427, Auckland, 2140  
New Zealand

Phone: (09) 577 0000  
www.hella.co.nz





**HELLA GmbH & Co. KGaA**

Rixbecker Straße 75  
59552 Lippstadt, Germany  
Tel.: +49 2941 38-0  
Fax: +49 2941 38-7133  
Internet: [www.hella.com](http://www.hella.com)

© HELLA GmbH & Co. KGaA, Lippstadt  
922 999 142-612 J01770/EL/05.21/1.2  
Subject to technical and price modifications.  
Printed in Germany