

# Logistics Guideline for OE Suppliers

## HP-C-516





## TABLE OF CONTENTS

<b>1</b>	<b>Foreword</b> .....	<b>4</b>
<b>2</b>	<b>Area of application</b> .....	<b>5</b>
<b>3</b>	<b>Terms and definitions</b> .....	<b>6</b>
<b>4</b>	<b>General points</b> .....	<b>7</b>
4.1	Prerequisites to the supply of series production .....	7
4.2	Logistics directive, additional agreements and appendices .....	7
4.3	Logistic costs .....	8
<b>5</b>	<b>Packaging</b> .....	<b>10</b>
5.1	General points .....	10
5.2	Packaging specification .....	16
5.3	Controlling returnable packaging .....	19
5.4	Summary of packaging .....	22
<b>6</b>	<b>Supply classes</b> .....	<b>25</b>
6.1	General points .....	25
6.2	Pre-conditions .....	25
6.3	Definition of supply classes .....	26
<b>7</b>	<b>Shipping</b> .....	<b>30</b>
7.1	General points .....	30
7.2	Shipping and transport with "FCA" (Free Carrier) as term of delivery .....	32
7.3	Shipping and transport with "DDU" (Delivery Duty Unpaid) as term of delivery .....	34
7.4	Shipping and transport documents .....	36
<b>8</b>	<b>Process related general topics</b> .....	<b>48</b>
8.1	Consignation & credit note .....	48
8.2	Purchase commitment .....	48
8.3	Engineering Change Management .....	49
8.4	Deviation management .....	49
8.5	SOP & EOP management .....	51
8.6	Traceability .....	52
<b>9</b>	<b>Data interchange</b> .....	<b>53</b>
9.1	Electronic data interchange (EDI) .....	53
9.2	WEB-EDI .....	53
9.3	Fax/E-mail .....	53
<b>10</b>	<b>Logistics quality</b> .....	<b>54</b>
10.1	Malperformance claims towards suppliers .....	54
10.2	Logistics supplier assessment .....	54
10.3	Escalation levels .....	54
10.4	Logistics audit .....	55
10.5	List of possible logistics faults .....	56



<b>11 Preliminary suppliers and production management</b> .....	<b>57</b>
11.1 Preliminary suppliers .....	57
11.2 Production & storage .....	58
<b>12 Other</b> .....	<b>60</b>
12.1 VDA recommendations.....	60
12.2 Mutually applicable documents.....	60
12.3 Change documentation/Revision index .....	61

## 1 Foreword

Day by day, we face up to the challenge of fulfilling our customers' great expectations and wishes. For HELLA logistics, this means every logistics activity is carried out under the aspect of **customer satisfaction**, both internal and external. This requires a smooth flow for logistics processes throughout all the stages of the supply chain.

Customer satisfaction is a crucial success factor for HELLA as a supplier of complex products for the international automotive industry and consequently for you, our contractor (termed "supplier" hereafter). **Lean** and **transparent logistics processes** are important requirements that can only be achieved and guaranteed through the combined efforts of supplier and HELLA.

This Logistics Directive (referred to hereafter as HP-C-516) sets out the logistics requirements for suppliers. HP-C-516 defines **smooth processing** between HELLA and the supplier and must always be taken into consideration during development, design and planning of logistics concepts. It serves as a basis for the creation of a controlled supply chain which is required within the context of the HELLA production system (HelPS).

The following logistic concerns must be taken into account in the overall process:

- Reduction of complexity and increase in flexibility
- Synchronization of processes
- Reduction of control expenditure and simplification of material flow
- Guarantee of process safety
- Suitable protection of components in order to minimize damage
- Avoidance of waste and reduction of processing times
- Continual improvements along the whole process chain

Please read HP-C-516 carefully. If you have any questions about this directive, please get in touch with your respective contact person.



**Ludger Meerbecker**

Vice President Corporate Logistics



**Martin Jungbluth**

Executive Vice President

Global Head of Corporate Purchase



## **2 Area of application**

Incoming deliveries are checked by HELLA with regard to observance of HP-C-516 and the additional agreements made during the project. If supplementary agreements are made in addition to this HP-C-516 they must also be kept.

HP-C-516 is published in German and English. In the event of deviations, the German version shall be binding.

Special country-specific regulations will be agreed separately between parties.

### 3 Terms and definitions

CMR	Convention Marchandise Routière (convention concerning transport contracts in international road haulage)
DDU	Delivered Duty Unpaid (...named place)
DFÜ	Remote data transmission
DFÜ-WBS	Remote data transmission of goods issue slip
DIN	German standardization institute
EDI	Electronic Data Interchange
EDIFACT	Electronic Data Interchange For Administration, Commerce and Transport
Receiving plant	This is the HELLA plant the supplier sends the material to
EN	European standard
ESD	Electrostatic Sensitive Device
FCA	Free Carrier (...named place).
FIFO	First-In-First-Out
GLT	Large load carrier
HeIPs	HELLA production system
IPPC	Integrated Pollution Prevention and Control
ISPM	International Standard of Phytosanitary Measures
KLT	Small load carrier
CIP	Continual improvement process
LHM	Loading equipment
LT	Load carrier
LE	Load unit
MMOG/LE	Materials Management Operations Guide/Logistics Evaluation
PHM	Packing aid
RESY	Recycling guarantee for transport packaging made of paper and cardboard
SLT	Special load carrier
SOP	Start of Production (start of series production)
VDA	German Association of the Automotive Industry
VDW	German Association of the Corrugated Cardboard Industry
VMI	Vendor Managed Inventory

## 4 General points

### 4.1 Prerequisites to the supply of series production

Before the first delivery to HELLA, the following points must be coordinated with HELLA, as well as with the purchaser and logistics planner responsible:

- Presentation of HP-C-516 at the supplier's
- Conclusion of possible additional agreements
- Presentation of the contract appendices at the supplier's
- Agreement of terms of delivery according to INCOTERMS 2000
- Definition of the supply class
- Definition or agreement on packaging and circulating quantities
- Agreement about data integration (EDI connection)
- Definition of contacts
- Presentation of contingency plan by the supplier

### 4.2 Logistics directive, additional agreements and appendices

HP-C-516 provides the logistical basis for the supply relationship between the supplier and HELLA. Additional agreements can be made in addition to HP-C-516. More specific regulations in additional agreements take priority over the regulations in HP-C-516.

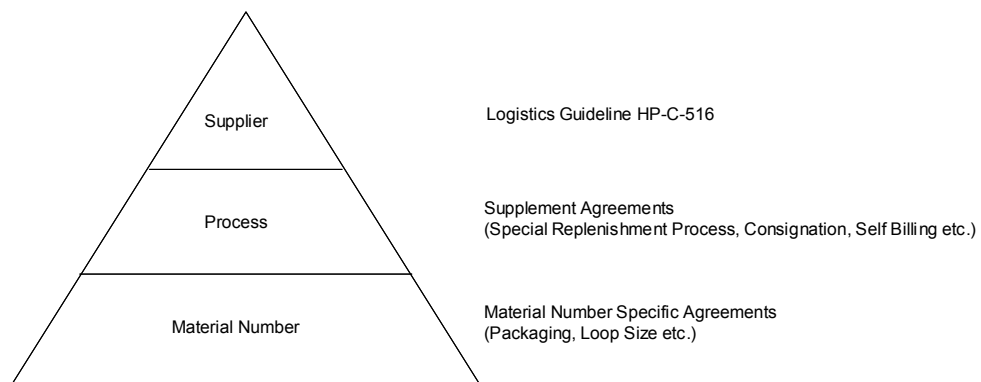

## 4.3 Logistic costs

### 4.3.1 General requirements

The Hella purchase department may ask the supplier to quote an A-/B-Price in the following cases:

- New parts
- Technical modifications (in accordance with HP-C 509)
- Logistics changes (e.g. packaging and transport)
- Product relocation

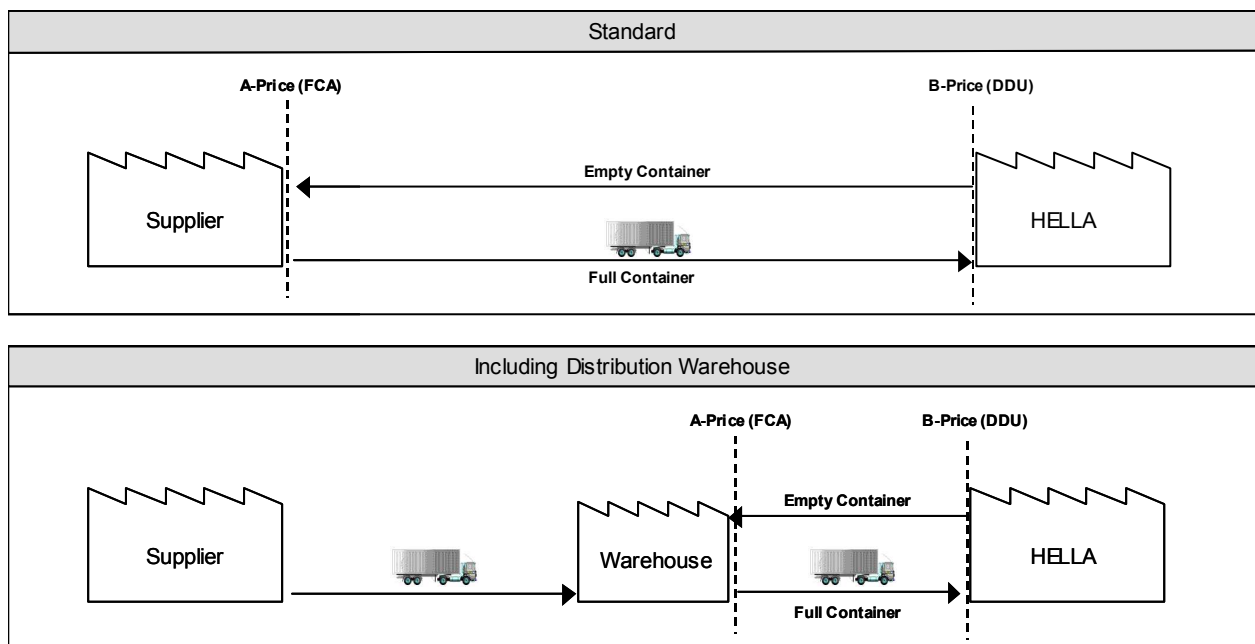

### 4.3.2 Definition of A-price

The A-price (= part price) corresponds to the term of delivery "Free Carrier" (FCA according to INCOTERMS 2000) and includes all the supplier's internal logistics expenditure. The following costs are generally included in the A-price:

- Pre-logistics costs (e.g. logistics costs for raw materials and preliminary materials)
- Residue-free cleaning of the containers (inc. label removal)
- Parts protection
- Packing in load carriers
- Disposable materials and packaging
- Marking of parts or containers
- Loading onto the freight carrier and expenditure for securing the load



### 4.3.3 Definition of B-price and “Delta A/B-price”

The B-price corresponds to the delivery term “Delivery Duty Unpaid” (DDU according to INCOTERMS 2000) and contains the costs for transfer from the supplier’s to the respective HELLA plant. The HELLA pool packaging should preferably be taken into consideration.

The following logistics costs result from the difference between the A-price and B-price, or “Delta A/B-price”:

- Transport costs (transport of full **and empty containers**, inc. all indirect costs)
- Costs for transport containers (planning and development, investment or rental and repair of the containers, deviating additional packaging, overseas packaging)
- Costs for external storage and handling (unloading, repacking, commissioning and sequencing, storage, transport and provision up to transfer point according to delivery term)

### 4.3.4 Agreement of logistics costs

In the quotation submitted to HELLA, the supplier must list the logistics costs per part number. This means it is necessary to list both the A-price and the B-price for each part number in the quotation.

HELLA checks the logistics costs offered and agrees adjustments with the supplier if necessary. The supplier revises the logistics costs if necessary and sends the revised quotation to HELLA Purchasing.

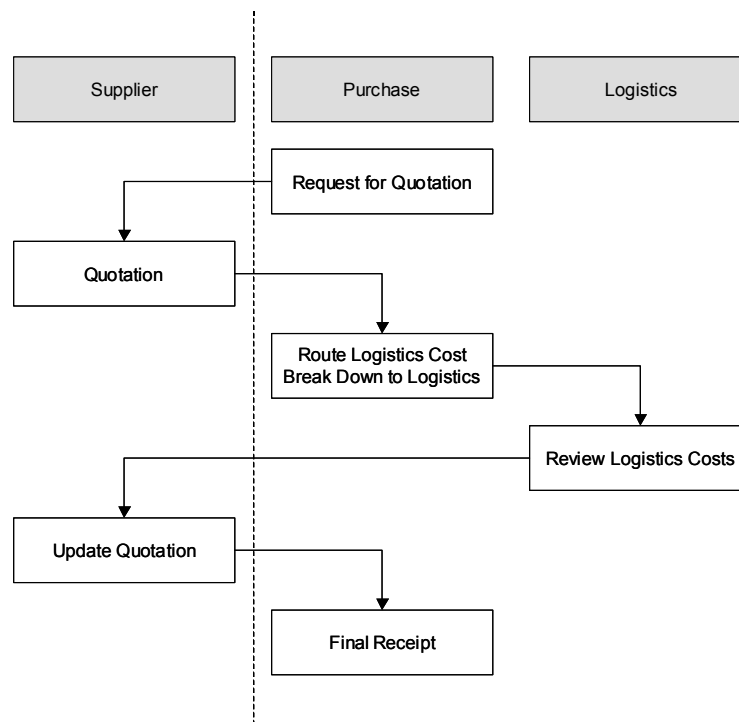

## 5 Packaging

### 5.1 General points

#### 5.1.1 Definitions of terms

The terms specified by HELLA are defined below:

Term	Definition
Packaging	General generic term for all packaging elements
Disposable packaging	Packaging that can only be used once.
Returnable packaging	Packaging that can be used several times without impairing the protective, transport, storage and handling function.
Load carrier (LT)	The load carrier surrounds the product.
Small load carrier (KLT)	Small load carriers that only form a load unit and can be transported with the aid of loading equipment (e.g. pallet).
Large load carrier (GLT)	Large load carriers that form a load unit and can be transported without loading equipment.
Special load carrier (SLT)	Item-specific load carriers that are only used for one special product.
Load unit (LE)	A load unit is the unit that is transported and stored. A load unit can be made up of a load carrier or a combination of small load carriers and loading equipment.
Loading equipment (LHM)	Loading equipment is used whenever the load carrier cannot be transported on its own (e.g. pallets, covers etc.).
Packing aid (PHM)	Packing aids are used to hold/protect the product inside a load carrier (film/foil, intermediate layers etc.).

#### 5.1.2 Avoiding packaging waste

When packaging is planned, economical, ecological and logistical aspects must always be taken into consideration and implemented according to the following priorities:

Avoidance	Packaging must be restricted to the absolute minimum volume and weight necessary to protect the goods.
Reduction	Repeated use must be guaranteed by the use of returnable packaging. The use of returnable packaging must always be preferred, taking the above principle into account. The share of disposable packaging must be kept as low as possible.
Recycling	The eco-friendly recycling of returnable and disposable packaging must be guaranteed. In order to do justice to the requirements in the Packaging Directive and not place an unnecessary burden on the environment, only eco-friendly materials may be used and the statutory requirements must be met.

### 5.1.3 Laws, standards, forms

All the packaging delivered to HELLA must comply with the valid safety regulations and guarantee good handling or ergonomics. It has to comply in general with the country-specific standards applicable at the HELLA receiving plant in terms of dimensions and material.

The following general conditions must be heeded if the HELLA receiving plant is in Germany

DIN 6120	Marking of packing material and packaging for recycling (plastics)
DIN 15155	Pallets, skeleton box pallet with 2 front flaps
DIN EN 13698-1	Product Specification for Pallets - Part 1: Manufacturing 800 mm x 1200 mm flat pallets from wood
DIN EN 13698-2	Product Specification for Pallets - Part 2: Manufacturing 1000 mm x 1200 mm flat pallets from wood
VerpackV	Packaging Directive
KrwG	Law governing recycling and waste
94/62/EEC	European packaging directive

Depending on the agreement, the following forms are used (the forms are included as appendices):

HELLA 7700	Packaging data sheet
HELLA 7729	Circulation log
HELLA 2906	Agreement on the procurement and use of returnable packaging
HELLA 2907	Packing item comparison (difference notice)
HELLA 2908	Request form for packing items

### 5.1.4 Packaging requirements

Depending on the type of packaging chosen, the following requirements must be met:

- Damage-free delivery of the goods
- Optimum packaging filling level
- Adherence to the prescribed standard dimensions and weights
- Use of recyclable materials
- Minimum use of disposable packaging
- Marking according to section 7.4.3 of this directive
- Creation of sensible load units
- Stacking ability of load units
- All-side marking of load units with regard to limited stacking ability
- Transportation safety

- Straightforward handling of load units by industrial trucks
- Straightforward manual handling of the load carriers

### 5.1.5 Permissible packaging material

Paper/cardboard in a natural state and free of non-paper components must be used as packaging. Saturated, impregnated, painted or laminated paper/cardboard is not permitted. Packaging made of corrugated cardboard should have the RESY symbol from VDW.

Wood may only be used in a solid form and may not be treated. It has to be free of plywood, fiber boards, chipboards, laminated chipboards, plastic bushes and bases as well as protective or clamping elements with a thickness > 10 mm.

For packaging made of wood that is imported from or to be exported to non-European countries, the “Directive for regulating wooden packaging material in international trading”, following the IPPC standard, ISPM No. 15 must also be heeded.

Filling material such as polystyrene chips, wood wool etc. are not permissible.

Marking is carried out according to DIN 6120.

### 5.1.6 Disposable packaging

If disposable packaging is used, the following symbols must be heeded/used depending on the application:

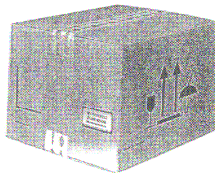

Material	Wellplast (corrugated plastic) or corrugated cardboard (dimensioning depending on requirements profile)
Closure	Reinforced adhesive tape (no metal staples)
Handling symbols	The well-known and generally comprehensible international symbols must be printed on

Cartons must not project over the edge of pallets.

When disposable packaging is used, it must always be checked whether a Wellplast container can be used as an alternative to cardboard boxes.

### 5.1.7 Returnable packaging

The use of returnable packaging is specified in a separate agreement.

This requires detailed regulation of the dimensioning of circulating quantities, definition of ownership relations as well as the provision, inventory and account management of the load carriers. The containers must not be labeled or marked.

ESD-capable load carriers must be used for the delivery of ESD-sensitive components.

### 5.1.8 Packaging belonging to the supplier

In agreement with HELLA, the supplier can use his own disposable or returnable packaging. Prerequisite here is proof of ownership of the returnable packaging.

In the case of permanent use, an ID number must be requested by the supplier to guarantee packaging accounting.

### 5.1.9 Pallets

Returnable flat pallets according to DIN EN 13698 and skeleton box pallets must be used whenever the supplier can be integrated in the Euro-Pool system.

Disposable flat pallets are only accepted if the supplier cannot be integrated in the Euro-Pool system for returnable flat pallets. The entry height must be guaranteed (see DIN EN 13698).

General requirements:

- Sufficient stability to resist transport loads
- Perfect condition

### 5.1.10 Creating and securing load units (LE)

To guarantee efficient transport and storage, the following general requirements apply:

- Stability of the LE in terms of properties, shape and volume
- Stacking ability of load units
- The basic dimension of the load carriers (pallets) must not be exceeded by the packed material and load securing equipment
- Incomplete layers are not permitted (fill up with empty containers if necessary)
- The load units must be able to be handled by industrial trucks
- A load unit comprising plastic returnable containers must be covered by a cover lid.
- Load units must have plastic fastener straps along the long side (metal fastener straps are not permitted)
- Straps must not be allowed to cut into cardboard boxes and containers
- Edge reinforcements must be used whenever the safety of the load unit makes this necessary
- Securing LE through stretch film must be avoided

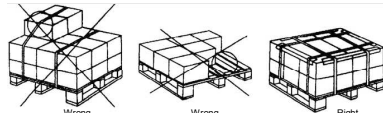
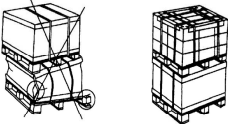
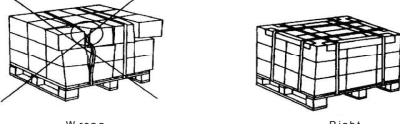
Full layers	Stacking ability	Securing / Edge protection
		

### 5.1.11 Dimensions and weights

Dimensions and weights are expressed in metric units (mm, kg).

For reasons of ergonomics, small load carriers must not exceed a total weight of **15 kg** and must be able to be carried by one person.

The load unit should adhere to the following basic dimension:

- L x W [mm] 1,200 x 800 (**Standard**)
- L x W [mm] 1,200 x 1,000 according to agreement with the respective receiving plant

The height of the load unit must not exceed 1,250 mm. In individual cases, a deviating regulation can be agreed with the receiving plant.

The maximum weight of the load unit is 1,000 kg gross.

### 5.1.12 Packaging identification

HELLA packaging always has an 8-digit ID number that is usually attached visibly to the packaging.

If suppliers' own returnable packaging is to be used permanently, an ID number must be requested from HELLA for this, too. As far as possible, the ID number must be attached visibly to the packaging.

The ID number is basic information about the packaging and must therefore always be given in the dispatch papers.

### 5.1.13 Replacement packaging

If the use of replacement packaging is necessary, this must also be agreed between the supplier, HELLA Purchasing and the receiving plant. Deliveries in replacement packaging must be released by the receiving plant. The regulations defined in this section are also applicable for the replacement packaging.

### 5.1.14 Overseas packaging

Containers in international transportation can be wooden crates or cardboard pallets and must meet the requirements in terms of stacking ability, transport loads, import restrictions (e.g. import of wooden packaging/IPPC-ISMP#15) etc. For international transportation, returnable packaging must always be agreed with the Logistics department at the receiving plant. The inner packaging must be defined by the supplier. Both the inner and outer packaging must guarantee top-quality delivery of the parts. The whole transport process must be taken into account for the definition of the packaging (e.g. exposure to wetness and heat through container on deck).

### 5.1.15 General state

Care must be taken that the surrounding packaging is in a good general state. Alongside the general "optical" overall appearance, this also includes the following properties:

- No humidity or wetness
- No materials sticking to it (oil, adhesives, coal/cement dust etc.)
- No smells (moldy, foul smell etc.)
- No external contents (waste, leaves etc.)
- No excessive rust on steel elements used (e.g. on skeleton boxes, steel tubs, support/stacking elements etc.)

### **5.1.16 Cleaning**

Empties must be cleaned by the supplier before use. Cleaning is carried out according to the necessary degree of cleaning of the product or HELLA requirements. Any invalid goods identification (e.g. labels or tags) must be removed.

### **5.1.17 Consequences of incorrect, missing or damaged packaging**

If the goods ordered are not delivered in the appropriate packaging quantity units or if packaging is used that does not correspond to the agreements, the supplier is obliged to take back the packaging in the case of deliveries within Europe. The supplier bears the cost for the return transport and repacking costs if necessary. If the supplier does not take back the packaging within a specified period or refuses to take back the packaging, he will be charged for the disposal of the packaging.

In the case of deliveries outside Europe, the supplier is charged with the cost of disposing of the packaging.

HELLA checks the condition of the packaging when it leaves the plant and when goods are received. If load carriers, returnable containers etc. recognized as not being usable, the costs (new procurement or repair) are charged according to the parties who caused the damage. If the supplier caused the damage, he receives the invoice together with a copy of the delivery note/bill of lading or pallet issue slip. In the case of faulty or unusable skeleton boxes, the purchasing price of a skeleton box is generally charged as the invoice value. This amount includes all the costs for repairs, handling costs and administrative expenditure.

HELLA reserves the right to charge the supplier internal repacking costs when packaging is damaged, incorrectly used or loaded contrary to regulations.

If the supplier is delivered packaging damaged by HELLA or if there are differences in quantity in the delivery, the procedure is as follows:

- The sender must be informed immediately by e-mail/fax about the type of damage and number of packages complained about. Respective dispatch papers must be included.
- Procedure is always only according to the instructions given by the HELLA contact.
- If the damaged packaging is to be returned empty, the supplier receives written instructions about this from HELLA. If empty packaging is returned without instructions from HELLA, the supplier will be charged with the freight costs incurred.
- Account adjustment is only carried out according to written instructions from HELLA.

## 5.2 Packaging specification

An agreement on the packaging is made between the supplier and HELLA for every product. A decision is made as to whether disposable or returnable packaging is to be used. In addition, it is defined whether the returnable packaging is provided by HELLA or to be procured by the supplier. Furthermore, responsibility and cost charging for the packaging is defined. Basically, the planning & specification of the packaging must be agreed with the respective packaging planner at the HELLA receiving plant. The specification is documented in the HELLA packaging data sheet (HELLA 7700).

### 5.2.1 Packaging planning

HELLA determines the internal requirements on packaging according to the “line back” principle. The following aspects are taken into special consideration:

- Ergonomic and safe handling
- Provision at the place of consumption
- Smoothed provision for production supply
- Internal supply concepts in production
- Small delivery cycles
- Elimination of waste
- Visualization and marking
- Storage and transport

The aim is to plan and release packaging early in the Time to Market process, and to have the required amount of series packaging available 6 months before SOP

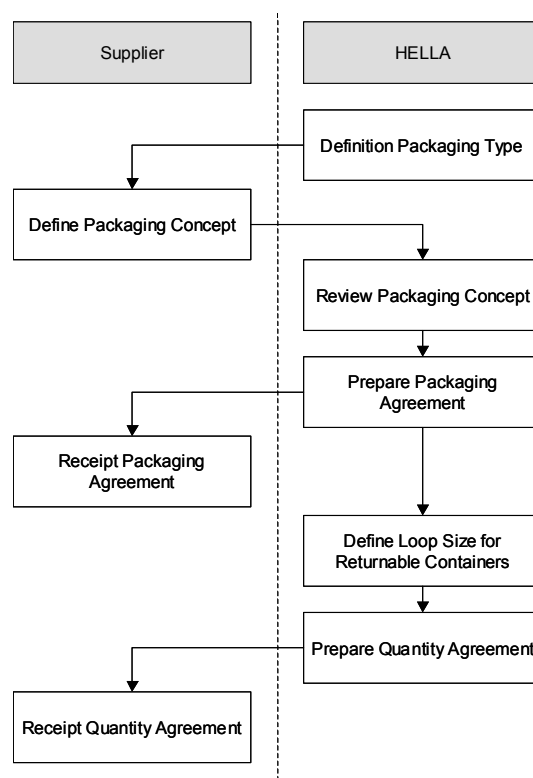



### 5.2.2 Specification of circulating quantities

The circulating quantities are calculated using the “Form for calculating circulating quantities” (HELLA 7729), the scope of the supplier’s and HELLA’s cost participation are specified bindingly and agreements are made about packaging accounting. HELLA returnable packaging may only be used for dispatch to HELLA.

### 5.2.3 Cost charging

If HELLA returnable containers are used, the supplier is provided with a circulating quantity for 8 working days free of charge. If the supplier requires a larger circulating quantity of returnable containers (e.g. for preliminary production, batch size forming etc.) the supplier shall bear the costs for the additional quantity.

The packaging remains the property of HELLA at all times. HELLA cannot make any claims for cost takeover or participation at any time unless deviating agreements have been made between the parties.

In the case of special load carriers, the supplier takes over the whole scope of procuring the packaging. The costs must be amortized over the service life.

The supplier always has to procure disposable packaging himself.

Criterion	Disposable packaging	HELLA returnable packaging	Special load carrier
Procurement	Supplier	HELLA	Supplier
Charging	Part price	8 days free of charge	Part price and service life
Ownership	-	HELLA	HELLA
Additional re-requirements	-	Procurement through HELLA 100% cost acceptance through supplier	Procurement through supplier 100% cost acceptance through supplier

### 5.2.4 Packaging release

For the packaging to be approved and released, the receiver plant must be sent a sample batch. The sample batch must be clearly marked as a “SAMPLE” and must not be mixed with series production and series packaging. The receiving plant is responsible for releasing the packaging. For this, the requirements of production, quality and logistics are taken into consideration. Final release is documented by the packaging data sheet “Packaging data sheet for parts and components for external and internal suppliers” (HELLA 7700) and sent to the supplier. The packaging data sheet is the official packaging agreement between the supplier and HELLA. Deviations from the agreement are only permitted after prior consultation and agreement by HELLA.

If the supplier does not object in writing within 5 working days, the packaging agreement is considered accepted.

If packaging is defined for a component, this must also be used for the subsequent deliveries unless a deviating agreement is reached.

### **5.2.5 Optimizing filling levels**

Packaging must always be delivered by the supplier with a maximum filling level, observing the permissible requirements such as maximum weight, stacking height, packing height etc.. If the filling level should change (changed filling quantity in containers, increase in packing density), the supplier is obliged to request agreement with HELLA before delivery and have it approved. Filling level optimization must be checked continually by suppliers and carried out in cooperation with HELLA.

## 5.3 Controlling returnable packaging

### 5.3.1 Account management

#### 5.3.1.1 Creating an account

A packaging account is set up for every supplier who delivers in HELLA returnable packaging.

The supplier is given a separate packaging account for every type of packaging and every goods recipient (plant within HELLA), in which his supplier number is assigned to the respective packaging identification and number of the goods recipient.

Criterion	Information
Packaging account	Supplier number + packaging identification + goods recipient
Supplier number	Number of the supplier in the HELLA system
Packaging identification	Identification of the packaging in the HELLA system
Goods recipient	HELLA plant

#### 5.3.1.2 Booking information

The incoming and outgoing packaging in day-to-day business is recorded in the packaging account. The account is updated every time returnable packaging is moved. The account records

- The date of delivery (arrival at/departure from the supplier's)
- Packaging type and load unit (e.g. container, Euro pallet, cover lid, inserts)
- Quantity
- Delivery note number / pallet issue slip number.

Corrective bookings are made to record missing or destroyed packaging and to balance respective accounts, in order to guarantee the closeness of the system.

The causing party is responsible for the costs of missing or damaged packaging.

#### 5.3.1.3 Bookings and balancing the packaging account

Together with the minimum stocks, the coordinated dynamic packaging stocks form the basis for the supply of empties to the supplier by the respective packaging account partner/goods recipient.

The supplier for whom a packaging account has been set up usually receives an account statement with the movements of the past period for each packaging ID number once a month.

The account statements must be checked by the supplier within 2 weeks of receipt and are considered recognized by the supplier without contradiction and presentation of proof concerning any differences established.

The packaging account is then given a new balancing date.

If differences are established but not proved, HELLA will charge the supplier with the repurchasing costs of the packaging.

Exceptions to this regulation are packaging which is not relevant for agreement, in other words packaging that moves in closed circuits between the supplier and HELLA (e.g. special load carriers). In the case of this packaging, balancing the stocks at the end of the month is sufficient.

During empties processing, the supplier meets all HELLA requirements related to packaging account management without delay.

#### **5.3.1.4 Packaging accounts**

HELLA manages the packaging accounts exclusively with supplier. No accounts are created for any forwarding agents commissioned. All the agreements made between suppliers and forwarding agents about packaging are not binding for HELLA.

If the supplier uses packaging that is the property of a forwarding agent, it must also be guaranteed for this packaging that the contents of the delivery note correspond to the documents (delivery note, bill of lading, label, DFÜ goods issue slip) and the data content of the DFÜ. The supply relationship must be presented as if this were packaging delivered by the supplier. All the circulating packaging must be listed on the delivery papers, i.e. pallets, intermediate layers, containers etc..

The principles of the “Cologne/Bonn pallet exchange method” are to be applied. A pallet can only be exchanged when the forwarding agent can prove that exchange has taken place with the supplier, i.e. HELLA enters no commitment to the forwarding agent, and the forwarding agent has announced the pallet exchange in advance.

#### **5.3.1.5 Inventory by the supplier**

HELLA has the right to demand physical stocktaking of the returnable packaging by the supplier at any time. Such a physical key date inventory must always be carried out once a year on the date specified by HELLA. A stock list prepared by HELLA forms the basis of the inventory check. If the actual stock of returnable packaging is larger than the stock in the stock list, this packaging must be specified by the supplier. If the inventory stocks are not communicated on the key date, the stocks in the stock list are regarded as accepted.

#### **5.3.2 Packaging request**

The supplier is to inform the receiving plant of packaging requirements by fax 5 days before they are required to be sent. The standardized form “Request form for packing items” (HELLA 2908) is to be used for this.

Delivery to the supplier is carried out after his packaging account has been checked and the packaging requirements have been determined by HELLA.

#### **5.3.3 Consequences of damaged returnable packaging or differences in quantities on delivery**

HELLA checks the condition of the packaging when it leaves the plant and when goods are received. HELLA is authorized to charge the supplier repacking costs when packaging is damaged, incorrectly used or loaded contrary to regulations.

If the supplier is delivered packaging damaged by HELLA or if there are differences in quantity in the delivery, the procedure is as follows:

- The sender must be informed immediately by e-mail/fax about the type of damage and number of packages complained about. Respective dispatch papers must be included.
- Procedure is always only according to the instructions given by the HELLA contact.
- If the damaged packaging is to be returned empty, the supplier receives written instructions about this from HELLA. If empty packaging is returned without instructions from HELLA, the supplier will be charged with the freight costs incurred.

Account adjustment is only carried out according to written instructions from HELLA.



#### **5.3.4 Excess stocks at the supplier's**

HELLA expects regular return deliveries of excess packaging stocks. If the supplier should exceed his specified circulating stock level, HELLA reserves the right to charge for additional expenditure incurred.

#### **5.3.5 Ending or reducing delivery**

When deliveries are ended, the supplier is obliged to return all the packaging still on his premises to HELLA free of charge.

## 5.4 Summary of packaging

Photo	Information
	<p>“E1” plastic container</p> <p>Number: 477.112-00</p> <p>Exterior dimensions: 600 x 400 x 320 mm</p> <p>Interior dimensions: 566 x 367 x 287 mm</p>
	<p>“E2” plastic container</p> <p>Number: 477.111-00</p> <p>Exterior dimensions: 400 x 300 x 167.5 mm</p> <p>Interior dimensions: 366 x 260 x 134 mm</p>
	<p>“EL” plastic container</p> <p>Number: 477.113-00</p> <p>Exterior dimensions: 600 x 400 x 320 mm</p> <p>Interior dimensions: 566 x 367 x 287 mm</p> <p>ESD-capable</p>
	<p>“E3” plastic container</p> <p>Number: 477.110-00</p> <p>Exterior dimensions: 400 x 300 x 120 mm</p> <p>Interior dimensions: 358 x 258 x 100 mm</p> <p>ESD-capable</p>
	<p>“E4” plastic container</p> <p>Number: 477.110-10</p> <p>Electrically conducting (black)</p> <p>Exterior dimensions: 400 x 300 x 170 mm</p> <p>Interior dimensions: 358 x 258 x 152 mm</p>
	<p>Steel container</p> <p>Number: 477.102-00</p> <p>Exterior dimensions: 475 x 320 x 200 mm</p> <p>Interior dimensions: 450 x 295 x 185 mm</p>





Photo	Information
	<p>Skeleton box pallet according to DIN 15155</p> <p>Number: 477.002-00</p> <p>Exterior dimensions: 1240 x 835 x 970 mm</p> <p>Interior dimensions: 1210 x 800 x 800 mm</p>
	<p>Container on wheels</p> <p>Number: 477.007-00 or 477.007-01 (with towing bar)</p> <p>Exterior dimensions: 1220 x 830 x 1460 mm</p>
	<p>Cover lid for 477.112-00 and 477.113-00</p> <p>Number: 477.122-09</p>
	<p>Cover lid for 477.111-00</p> <p>Number: 477.111-09</p>
	<p>Cover lid for 477.113-00</p> <p>Number: 477.113-09</p>
	<p>Cover lid 400x300 for 477.110-00 and 477.110-10</p> <p>Number: 477.110-05</p>

Photo	Information
	<p>Euro pallet</p> <p>Number: 477.200-00</p> <p>Dimensions: 1200 x 800 x 144 mm</p>
	<p>Industrial pallet</p> <p>Number: 477.201-00</p> <p>1200 x 1000x 150 mm</p>
	<p>Cover for Euro pallet</p> <p>Number: 480.017-65</p> <p>Dimensions: 1204 x 808 x 94 mm</p>
	<p>Cover for industrial pallet</p> <p>Number: 480.017-60</p> <p>Dimensions: 1207 x 1010 x 67 mm</p>



## 6 Supply classes

### 6.1 General points

On account of the different processes, requirements and obligations towards suppliers concerning logistics processes, HELLA has defined standardized supply classes for the different components and delivery situations in order to guarantee cost-optimized supplies control.

The allocation of a component to a supply class is determined by HELLA and depends on the following criteria:

- Volume of commodity flow
- Component value
- Component dimensions
- Distance between the supplier's delivery location and the respective HELLA plant
- Freight concepts
- Supplier's delivery performance
- Supplier's logistics process performance

Class	Designation	Agreement
1	Just in Time (JIT)	Additional agreement
2	Supplier Kanban	Additional agreement
3	Vendor Managed Inventory (VMI)	Additional agreement
4	Planning	None necessary, see requirements in chapter 6.3.4
5	Distributor	Additional agreement

### 6.2 Pre-conditions

In principle, the supplier must fulfil the following pre-conditions to be able to take part in the process with standardized supply classes:

- Data reception (EDI, e-mail, fax etc.) must be guaranteed permanently
- Prompt acceptance and processing of messages and orders on the day of receipt (if appropriate also at connected locations with central reception area) must be guaranteed
- All data boxes transmitted are imported
- Missing and incomplete data transmissions (e.g. comparison of last/current delivery schedule number) are recognized automatically.

All the delivery dates indicated are the dates the goods are to arrive at the respective HELLA receiving plant or consolidation point. The supplier receives the preview data and horizons that HELLA in turn receives from its customers. The supplier is obliged to deliver only the currently requested quantities bindingly on schedule, independently of statutory, church-related and country-specific restrictions. This obligation exists independently of the entrepreneurial responsibility of the supplier to define internal production batch sizes or of respective production releases which have to be agreed separately by HELLA.

## 6.3 Definition of supply classes

### 6.3.1 Just in time (JIT)

At HELLA, the term “Just in time” processing is used to describe direct processing with continual material flow which is not put into storage. Deliveries can be once or more per day or use the WOW concept (Warehouse on Wheels).

JIT processing is used as a sorted delivery form if a supplier produces large parts with only a few variants continually and according to day-to-day HELLA requirements (in “flow production – production-synchronous production”).

Characteristic for this continual production and delivery process are the smallest possible handling steps from the supplier’s last production step to the HELLA assembly location.

With this JIT method, HELLA determines the required delivery amounts up to several times a day on the base of planning figures and transmits quantity and schedule information to the supplier using the call-off schedule.

A specific additional agreement is made between HELLA and the supplier for this supply class.

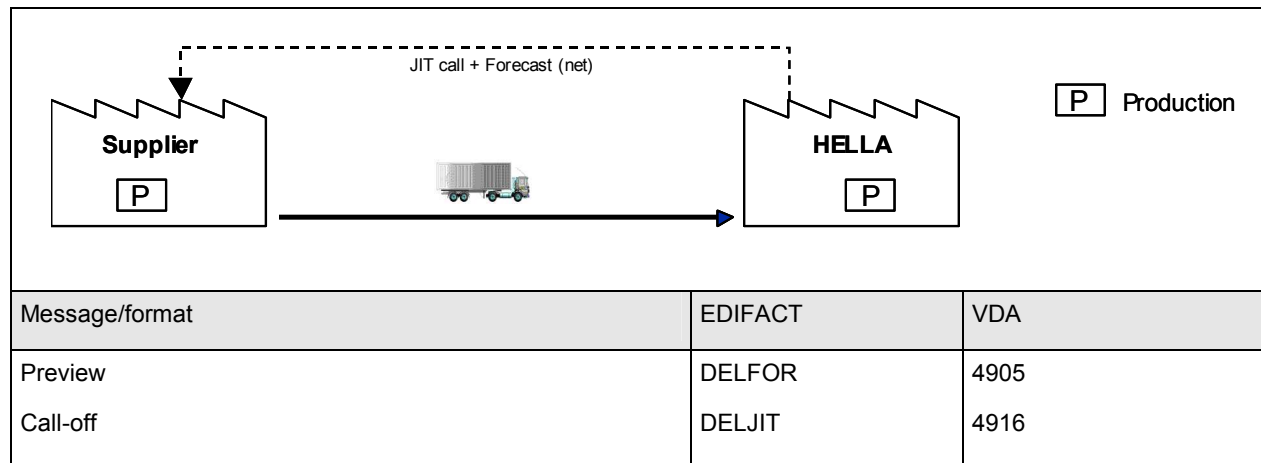

### 6.3.2 Supplier Kanban

The consumption-controlled supplies control using the Kanban method is oriented on HELLA's consumption values. HELLA transmits the quantity and schedule information to the supplier using a quantity call.

In addition to the quantity calls, the supplier receives preview data on the basis of net requirements in the form of a delivery schedule (to be able to plan capacities and resources in the mid and long-term). These preview data are not binding for HELLA.

A specific additional agreement is made between HELLA and the supplier for this supply class.

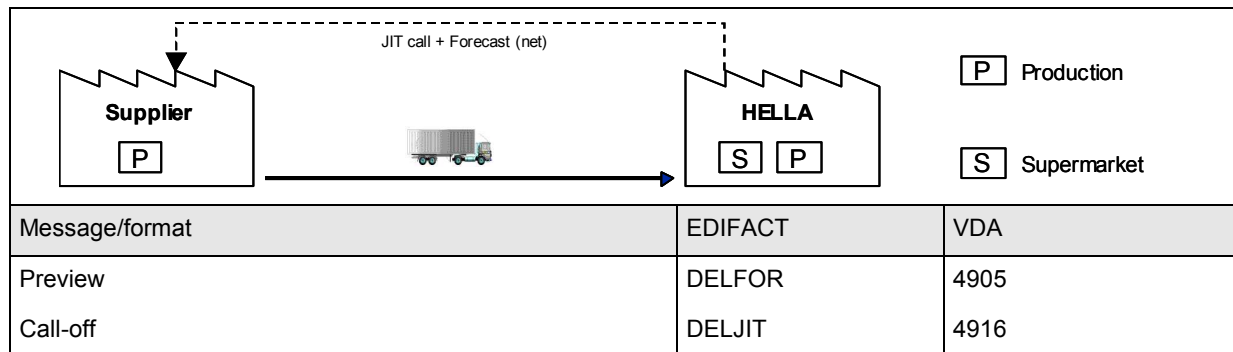

### 6.3.3 Vendor Managed Inventory (VMI)

In the case of VMI, the consumption-oriented supplies control is the responsibility of the supplier. On the basis of stock and movement data, the supplier must guarantee the stocks at HELLA within agreed minimum and maximum levels.

In addition to the stock and movement data, the supplier receives preview data on the basis of gross requirements in the form of a delivery schedule (to be able to plan capacities and resources in the mid and long-term). These preview data are not binding for HELLA.

HELLA is responsible for managing the warehouse and ensuring the correct control data.

This method is used in combination with consignment. A specific additional agreement is made between HELLA and the supplier for this supply class.

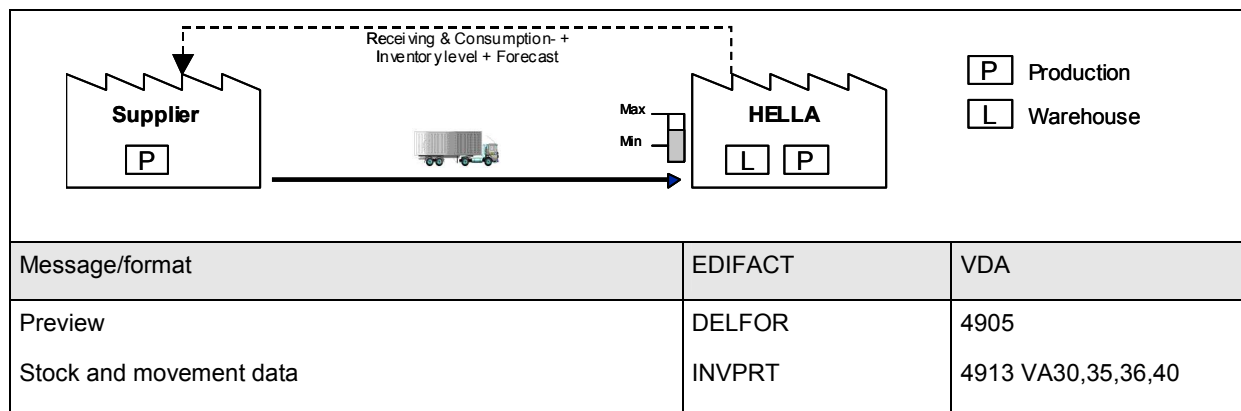

### 6.3.4 Disposition

This supply class will usually be employed, if no separate agreement for the control of replenishment is made with supplier. In this supply class, HELLA transmits delivery dates and quantities to the supplier according to internal requirement planning on the basis of delivery schedules. The supplier must deliver exactly according to the order data.

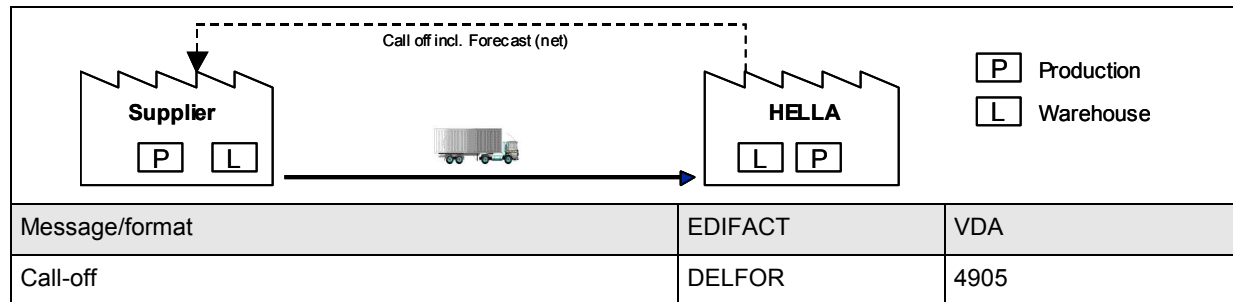

#### 6.3.4.1 Taking over the delivery schedules in the supplier's own system

To guarantee a smooth production and supply process, HELLA provides suppliers with delivery schedules and requirements previews analogous to its customers' preview schedules. The date the goods arrive at HELLA is always listed as the delivery date. This applies for all terms of delivery.

#### 6.3.4.2 Carrying out plausibility checks

If the supplier does not receive any delivery schedules within a defined or usual period, HELLA must be informed without delay. If delivery schedules are faulty or seem implausible to the supplier, the supplier must clarify the situation with HELLA.

#### 6.3.4.3 Short-term changes in quantities

Short-term reductions in quantities must be taken into account by the next delivery date. Short-term changes in quantity of +20% must be realized within five working days. Deviations can be agreed separately.

#### 6.3.4.4 Processing the current delivery schedule

Delivery quantities and delivery dates can be seen in the delivery schedules. If no written objection is made within one working day of the delivery schedule being transmitted, the quantities and dates listed are considered confirmed. The rolling forecast is updated at least once per week. Delivery schedules are valid until they are replaced by the respective following delivery schedule. The received cumulative quantity (FZ) is shown on the delivery schedule for each supplier. The cumulative quantity shows all the booked deliveries from a certain date up to the key date of the current delivery schedule. In addition, the adjustment-cumulative quantity is shown, which indicates the update of the quantities ordered up to the respective delivery date. The current delivery schedule number and the replaced delivery schedule number are shown. This enables the changes to the previous issue to be recognized immediately.

#### 6.3.4.5 Special forms

Back orders can be shown on the delivery schedule. Back orders is the term used for the positive difference between the call-off cumulative quantity valid on the key date of the current delivery schedule and the received cumulative quantity. In the case of back orders, special measures must be initiated to eliminate these immediately (e.g. extended shifts, weekend work etc.). HELLA must be informed about the cause, measures initiated, quantity and schedule. The information must be provided both by telephone and in writing (fax, e-mail).

### 6.3.4.6 Public holidays & other restrictions

The prescribed dates and call-off quantities must always be kept, regardless of statutory and church-related holidays and country-specific limitations.

### 6.3.5 Distributor

Within the context of this supply class, the supplier is also the distributor. The distributor takes over the function of a supplier and logistics service provider. The procurement, planning, storage and transport to a defined transfer point at HELLA is the responsibility of the distributor.

The control method is agreed separately with the respective distributor.

A specific additional agreement is made between HELLA and the supplier for this supply class.

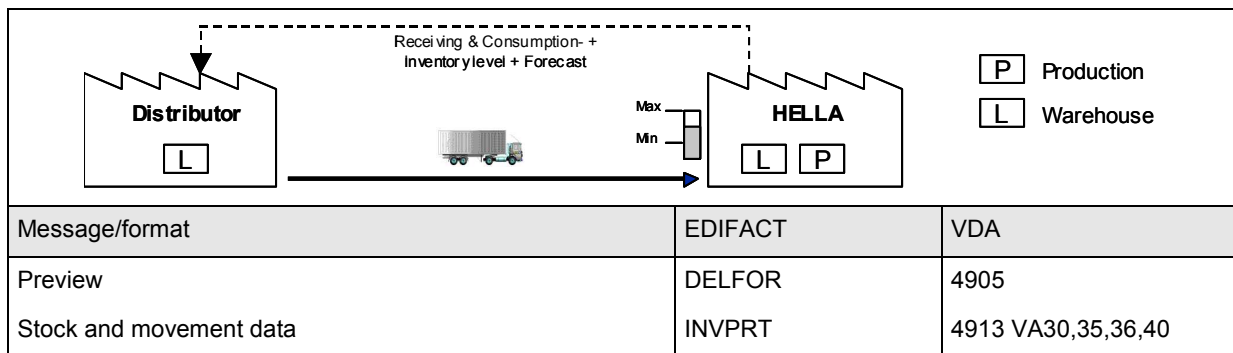

## **7 Shipping**

### **7.1 General points**

#### **7.1.1 Means of transport**

Different means of transport can be used depending on weight, quantity and volume:

- Parcel service (up to 32 kg)
- Truck dispatch (individually packed goods, part and complete loads)

#### **7.1.2 Scheduled dispatch**

Scheduled dispatch must be clearly declared for the forwarding agent and the HELLA incoming goods department. The supplier notes the arrival date and arrival time at the HELLA plant on the shipping order to be handed to the forwarding agent. Deviations from existing delivery time window agreements must be coordinated with HELLA in advance.

#### **7.1.3 Problems with dispatch/transport procedures**

The supplier must inform both the forwarding agent and the respective planning department at HELLA without delay about any problems in the prescribed procedure, which includes problems caused by preliminary suppliers; this information must be communicated by phone and by e-mail or fax and stipulate the reason for and type of problem. These problems must be eliminated without undue delay if possible.

#### **7.1.4 Over-deliveries/advance deliveries**

The supplier is only authorized to make part deliveries, deliveries before the call-off has been issued and additional deliveries only after prior written agreement by HELLA. If the supplier transfers the goods to a forwarding agent, freight carrier or similar commissioned by HELLA contrary to this condition, the supplier bears the risk of transport until the goods are taken over at the HELLA receiving plant. Logistics costs for the storage and/or return of unauthorized over-deliveries or advance deliveries will be borne by the supplier.

#### **7.1.5 Determining weights**

The supplier is responsible for the correct determination of the gross weight and loaded weight of the shipment. If the weights specified are incorrect, HELLA charges the supplier with the additional freight costs plus an administration charge.

#### **7.1.6 Dispatch of hazardous goods**

The supplier is obliged to hand over the shipment for transport according to the hazardous goods regulations. The obligations and responsibilities borne by the supplier as the sender, packer/filler and loader are set out in §9 GGVS or section 1.4 ADR. The supplier is liable for all damage incurred through non-observance of the legal regulations.

#### **7.1.7 Returned goods**

The transport of return goods caused by the supplier is organized by HELLA unless agreed otherwise in advance in writing. The supplier bears the costs.

### **7.1.8 Extra tours**

Unscheduled extra tours at short notice are usually organized by the supplier and processed through a forwarding agent selected by HELLA in agreement with the supplier. Approval is always granted by the material planning department at the HELLA plants in agreement with the supplier. Costs for extra tours caused by the supplier are borne by the supplier.

### **7.1.9 Customs planning/customs handling**

Customs planning and handling can only be carried out in close cooperation with HELLA in the case of deliveries "FCA". In individual cases, agreements must be drawn up directly with the respective office at HELLA. Costs for missing or incorrect customs papers and/or customs planning and resulting follow-on damages that can be traced back to the supplier will be charged to the supplier (e.g. customs duties in the event of faulty preference certificates).

Customs papers and customs certificates must be prepared according to the respectively valid legal regulations.

The supplier must specify the country of origin and customs tariff number per HELLA part number for all goods deliveries to HELLA. In the case of goods originating in the EU, the supplier automatically provides these specifications through a long-term supplier agreement or individual supplier declaration. In the case of goods originating outside the EU, the country of origin and customs tariff number must be listed on the invoice. HELLA must be informed of any changes without undue delay.

The supplier must inform the customer and recipient of the goods adequately in advance about any obstacles in international goods traffic for the respective goods.

### **7.1.10 Declaration of origin of goods**

If the supplier has his place of business and/or place of manufacture within the European Union, the supplier has to issue a Supplier Declaration according to VO (EC) 1207/2001 (individual or long-term declaration) in accordance with the respectively valid EU regulations.

The supplier always receives a separate cover letter "Annual declaration" with the form to be used. The supplier returns the signed declaration to HELLA within 4 weeks of receipt or with the delivery at the latest.

If in exceptional cases the supplier draws up the Supplier Declaration on his own stationery or within the context of remote data transmission (DFÜ), this procedure must be agreed with HELLA in advance. If the supplier has his place of business and/or place of manufacture in a country which has a free trade agreement with the EU, he must issue a preference certificate (movement certificate/declaration of origin) for each delivery. The conditions of the free trade agreement must be observed.

## **7.2 Shipping and transport with “FCA” (Free Carrier) as term of delivery**

In the case of “FCA” as the agreed term of delivery, the forwarding agent and transport concept are defined by HELLA.

The supplier bears the costs for the transport of the goods to the agreed transfer point and must bear any additional costs incurred if his production is relocated.

The goods must not be handled by any other forwarding agent than the one specified by HELLA.

### **7.2.1 Shipping instruction**

Detailed specifications about the procedure and responsibilities are coordinated and agreed with the supplier in a separate shipping instruction.

### **7.2.2 Notification**

Generally speaking, the forwarding agent must be notified of the consignments of goods in good time on the day before loading, taking the duration of the transport into account.

The following points must be observed for notification of the shipment to the respective regional freight forwarder, unless otherwise agreed:

- Weight, number, type and dimensions of the load carriers
- Receiving plant with specification of the unloading bay
- Hazardous goods declaration (UN number, correct designation, hazardous slip number)
- Arrival date at HELLA
- Notification of the consignment of goods is made through the web platform of the regional freight forwarder
- The supplier is obliged to archive the notifications for at least three months and make these available to HELLA on demand. The HELLA receiving plant must provide details of the regional freight forwarder responsible.

### **7.2.3 Preparation of the consignment for dispatch**

Consignments should always be able to be picked up between 6 am and 6 pm. Details of the pick-up must be agreed between the forwarding agent and the supplier.

When the pick-up is made, empties must be able to be delivered at the same time. Unless agreed otherwise with the forwarding agent, unloading the empties for the supplier and loading of the consignment incl. clearance must be completed within one hour.

On request by the forwarding agent, the supplier is obliged to confirm the start and end of vehicle provision on a route slip. Delays in clearance as well as inappropriate loading and waiting times lead to additional costs which must be borne by the supplier.

When the goods are made ready, the exact call-of quantity according to the delivery schedule must be provided at the right dispatch time (incl. date and time if appropriate), taking transport time into consideration. The goods must be made ready in such a way that incorrect loading is impossible and product quality is guaranteed.





The regional freight forwarder and HELLA must be informed of problems with the dispatch procedure without delay. If the forwarding agent has to leave without the goods on account of unplanned waiting times, the supplier has to organize and carry out an extra tour on his own initiative and at his own costs.

#### **7.2.4 Loading**

Loading and clearance must be carried out as soon as the vehicle is provided. In as far as the supplier carries out the loading process, he has to load the goods in such a way that they can be transported safely and must follow the instructions given by the freight carrier drivers for safe loading.

To ensure the goods are loaded in good time and safe for transport, they must be made ready sorted according to where they are to be unloaded.

Where loads are to be dispatched without handling at a forwarding agent's terminal (this must be clarified directly when notification of the shipment is given), loading on the truck must be carried out separately according to unloading zones.

Individually packed goods that can be bundled and part shipments must be cleared centrally if a delivery location has more than one unloading point. Complete loads can always be delivered to individual unloading spots at one delivery location.

#### **7.2.5 Documentation**

The supplier must ensure that the regional freight forwarder is named on the delivery note and the bill of lading/shipping order (VDA 4922/DIN 5018), particularly if the pick-up is to be made by a sub-contractor of the regional freight forwarder.

All the information from the notification must be included on the bill of lading. The weight must be entered on the bill of lading as packing item and gross weight.

The supplier number must be specified with the complete supplier address. Delivery note and order number must be specified in the lines provided in all freight documents.

All the delivery documents must be enclosed with the shipping note and handed over with the consignment.

### **7.3 Shipping and transport with “DDU” (Delivery Duty Unpaid) as term of delivery**

With the term of delivery “DDU” the supplier is responsible for the delivery to the unloading location named by HELLA. Transport of the goods to the respective location must be carried out in such a way that the goods arrive in a perfect state i.e. without damage to the goods or packing material. Damaged goods are returned at the supplier’s cost. Follow-on costs proved to be caused by this damage shall be borne by the supplier.

Basically, all the means of transport used (including those of the service provider) must be able to be loaded and unloaded from the side as well as from the rear.

#### **7.3.1 Choice of forwarding agents**

The supplier is authorized to use forwarding agents/sub-contractors. Any staff used, including any sub-contractors, are also obliged by the supplier to meet the requirements of this contract. If a supplier commissions a forwarding agent, the commissioning may only be given after a check on performance has been carried out. Suitable criteria (condition of the vehicle fleet, reliability, availability, credit-worthiness, flexibility, observance of environmental requirements etc.) must be checked regularly by the supplier. Respective agreements must be made with the forwarding agents so that smooth transport can be carried out. This particularly includes pick-up times, contacts, contingency plans, exemption certificates for driving bans (e.g. on Sundays and public holidays) and customs requirements.

#### **7.3.2 Specification of the transport concept**

The supplier is responsible for ensuring that the specified transport concept meets the requirements. Agreements must be made with the forwarding agents so that smooth transport can be carried out. Important contacts such as

- Delivery cycles, transport routes and times, transport tracking
- Collective goods handling, direct deliveries
- Capacity limitations
- Exemption certificates for driving bans (e.g. ban on driving at the weekend, in smog)
- Contacts, exchange of information
- Use of sub-agents
- Customs requirements/customs handling

must be coordinated together with the forwarding agent. Contingency plans for handling transport must be specified and tested.

In addition, the supplier is obliged to take the goods acceptance times of the respective HELLA plant into account as well as specified delivery time windows.

#### **7.3.3 Shipment tracking**

The supplier must ensure that information about the delivery status of his part of the supply process chain can be provided at any time. This means the supplier and the freight driver responsible must be able to be reached at any time (24 hours a day, 7 days a week).



#### **7.3.4 Production supplies**

If there are complaints about the goods or problems with the transport, the supplier must ensure that replacement deliveries are possible for the receiving plant or for the commissioned forwarding agent at any time.

#### **7.3.5 Driving bans**

The supplier ensures that the goods can still be delivered on schedule even if driving bans are in place.

## 7.4 Shipping and transport documents

### 7.4.1 Freight-related documents

#### 7.4.1.1 Shipping order/bill of lading

Shipments may only be passed onto the forwarding agent accompanied by the completed shipping order according to VDA 4922 or bill of lading. The specification of load carrier type and quantity must be made separately according to unloading point. Templates for the shipping order can be ordered for a fee from the forwarding agent.

The bill of lading must list at least the following information:

- Delivery address
- Receiving plant/warehouse with details of the unloading point
- Weight and quantity of pallets / containers as well as their stacking ability
- Hazardous goods/hazardous goods class
- Arrival date at the respective receiving plant
- Number of supplier in the HELLA System

#### 7.4.1.2 DFÜ goods issue slip

A DFÜ goods issue slip (DFÜ-WBS) is to be used as reference and backup for the delivery note DFÜ according to VDA recommendation 4912.

The following information must always be provided on the DFU goods issue slip:

- The supplier plant, country code, zip code and dispatch location must always be specified as the sender. The production plant must be given for the supplier plant, so that the correct supplier packaging account is used for booking.
- Number of supplier in the HELLA System
- Delivery address
- Complete HELLA material and order number
- Revision level
- Cumulative quantity and number of every package and material number
- Position number
- Quantity and description (HELLA ID) of every returnable packaging (skeleton box, pallets, container etc.)
- Disposable packaging if used as loading or sub-loading carrier (e.g. disposable pallets, shipment boxes). The packaging must always be specified with the HELLA ID.

The correct specification of packing material ID number and packing material quantity in the delivery note-DFÜ and the DFÜ-WBS or on the delivery note are pre-conditions for exact packing material account management and thus the basis for the correct supply of suppliers with packing material.

## **7.4.2 Delivery note**

An individual delivery note according to DIN 4991 should only be used when it is not possible to prepare a DFÜ goods issue note.

The data / information of the delivery note are analogous to the DFÜ goods issue slip.

On the delivery note, only the items which belong to an order and the packing material used must be listed next to the material number.

The first delivery after modifications have been made must be marked "Delivery according to modified drawing status". The delivery note must be treated as an enclosure to the freight documents. It must not be attached to the goods.

Delivery notes must be handed over in the HELLA receiving plant together with the shipping note.

### **7.4.2.1 Proof of delivery**

If damage or deviations in the scope of delivery are established by HELLA upon delivery, HELLA can demand that the supplier present a written explanation within 2 working days confirming the undamaged and complete handover of the delivery to the forwarding agent commissioned by HELLA.

### **7.4.2.2 Customs documents**

All customs-related documents and information must be provided to the forwarding agent e.g. preference certificates (EUR. 1, UZ Form A and commercial invoice in triplicate).

### 7.4.2.3 Examples

#### 7.4.2.3.1 CMR Freight document

1. Exemplar für Tarifkontroll.	Exemplaire pour controle tarifaire	Exemplaar voor tariefcontrole	Esemplare per controllo tariffario	Copy for tariffcon.	Exemplar for tariffkontrollen
2. Exemplar für Absender	Exemplaire de l'expéditeur	Exemplaar voor Afzender	Esemplare per mittente	Copy for sender	Exemplar for Absender
3. Exemplar für Empfänger	Exemplaire du destinataire	Exemplaar voor Geadresseerde	Esemplare per destinatario	Copy for consignee	Exemplar for Modtager
4. Exemplar für Frachtführer	Exemplaire du transporteur	Exemplaar voor vervoerder	Esemplare per trasportatore	Copy for carrier	Exemplar for beforderer

<b>1</b> Absender (Name, Anschrift, Land) Expéditeur (nom, adresse, pays) <b>Hella KGaA Hueck &amp; Co.</b> Rixbecker Straße 75, 59552 Lippstadt/Germany Lieferanten-Nummer: 000030005		<b>INTERNATIONALER FRACHTBRIEF</b> <b>LETTRE DE VOITURE INTERNATIONALE</b> Diese Beförderung unterliegt trotz einer gegenseitigen Abmachung den Bestimmungen des Übereinkommens über den Beförderungsvertrag im internat. Straßengüterverkehr (CMR). Ce transport est soumis, nonobstant toute clause contraire, à la Convention relative au contrat de transport international de marchandises par route (CMR).	
<b>2</b> Empfänger (Name, Anschrift, Land) Destinataire (nom, adresse, pays) Hella Saturnus Slovenija d.o.o. PO Box 4008 1001 Ljubljana SLOWENIEN		<b>16</b> Frachtführer (Name, Anschrift, Land) Transporteur (nom, adresse, pays) NordSüd Sped.-Gesellschaft mbH Holunderstr. 11 33378 Rheda-Wiedenbrück DEUTSCHLAND	
<b>3</b> Auslieferungsort des Gutes Lieu prévu pour la livraison de la marchandise Ort/Lieu Ljubljana Land/pays Slovenia		<b>17</b> Nachfolgende Frachtführer (Name, Anschrift, Land) Transporteurs successifs (nom, adresse, pays)	
<b>4</b> Ort und Tag der Übernahme des Gutes Lieu et date de la prise en charge de la marchandise Ort/Lieu 59597 Erwitte Land/pays Deutschland Datum/Date 12.01.2010			
<b>5</b> Beigefügte Dokumente Documents annexés			
<b>6</b> Kennzeichen und Nummern Marques et numéros		<b>7</b> Anzahl der Packstücke Nombre des colis	
<b>8</b> Art der Verpackung Mode d'emballage		<b>9</b> Bezeichnung des Gutes Nature de la	
<b>10</b> Statistikknummer No statistique		<b>11</b> Bruttogewicht In kg Poids	
<b>12</b> Lademaß Chargement			

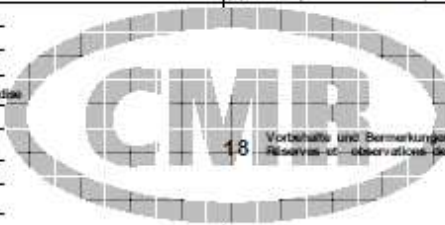
6	7	8	9	10	11	12
			car access.		5.967,6	6,584
0085084010	18	47700200				
0085084011	18	47700200				
0085087401	1	47720000				
0085087404	3	47720000				
0085089075	5	47720000				
0085089070	1	47720000				
0085089077	1	47711010				

<b>13</b> Anweisungen des Absenders (Zoll- und sonstige amtliche Behandlung) Instructions de l'expéditeur (Formalités douanières et autres)		<b>1</b> Zu zahlen vom: A payer par: Fracht Prix de transport Ermäßigungen Réductions Zwischensumme Solde Zuschläge Suppléments Nebengebühren Frais accessoires Sonstiges Divers Zu zahlende Gesamtsumme/Total à payer		Absender	Währung Monnaie	Empfänger Le Destinataire
Our order no.:						

<b>14</b> Rückentstaltung Remboursement		<b>15</b> Frachtzahlungsvoraussetzungen Prescription à l'affranchissement Pay: EXW Erwitte Urtage New:		<b>20</b> Besondere Vereinbarungen Conventions particulières	
<b>21</b> Ausgefertigt in Erwitte am 12.01.2010		<b>24</b> Gut empfangen Réception des marchandises am		Datum Date	
<b>22</b> Hella Distribution GmbH Erwitte Unterschrift und Stempel des Absenders (Signature et timbre de l'expéditeur)		<b>23</b> Obige Sendung vollständig, in ordnungsgemäßen Zustand und ordnungsgemäß geschert übernommen. Unterschrift und Stempel des Frachtführers (Signature et timbre du transporteur)		Unterschrift und Stempel des Empfängers (Signature et timbre du destinataire)	
<b>25</b> Angaben zur Ermittlung der Tarifentfernung mit Grenzübergängen von bis km		<b>28</b> Berechnung des Beförderungsentgelts Frachtpf. Gewicht in kg Tarifstufe: Sonderabmachung Güterarten Währung Frachttatz Beförderungsentgelt			
<b>26</b> Vertragspartner des Frachtführers ist kein Hilfs-gewerbetreibender im Sinne des anzuwendenden Tarifs					
<b>27</b> Amtl. Kennzeichen Nutzl. in kg Nr. LJ 414TT		Summe			
Anhänger					

Benutzte Gen.-Nr.  National  Bilateral  EG  CEMT



7.4.2.3.2 Shipping order

1) Versender/Lieferant Hella KGaA Hueck & Co. Rixbecker Straße 75 59552 Lippstadt/Germany		2) Lieferanten-Nr.		3) Speditionsauftrag-Nr. 77310		4) Nr. Versender beim Versandspediteur: <b>SPEDITIONS-AUFTRAG</b>			
5) Beladestelle 1504 / Hella KGaA Hueck & Co KG Recklinghausen		8) Sendungennummer		6) Datum 13.07.2009		7) Relations-Nr. <table border="1" style="display: inline-table; width: 40px; height: 20px;"><tr><td> </td><td> </td></tr></table>			
11) Empfänger Hella KGaA Werk 1012 Beckumer Straße 130 59555 Lippstadt / Germany		12) Kunden-Nr. 4557803		9) Versandspediteur NORD SÜD Speditionsgesellschaft mbH Overhagener Weg 14 59579 Erwitte		10) Spediteur-Nr. 250000001			
14) Anliefer-/ Abi destelle		15) Versendervermerk für den Versandspediteur: Antrag auf Stückzahlmäßige Übernahme wird gestellt		16) Eintreff-Datum 15.07.2009		17) Eintreff-Zeit 11:20			
18) Zeichen und Nr./ Lieferschein-Nr.	19) Anzahl	20) Packmitteltyp	21) SF	22) Inhalt	23) Lademittel-gewicht kg	24) Bruttogewicht kg			
81882372	48	Europalette	1	KFZ-Zubehör	28	468			
25) Summe		48	26) Rauminhalt cdm/Lademeter	1	27) Summen		28) 468		
29) Gefahrgut-Klassifikation keine				30) Gefahrgut-Bezeichnung: wenn vorhanden, siehe zusätzl. Vordruck keine					
31) Frankatur Ab Werk		32) Warenwert für SLVS		33) Transportversicherung vom Spediteur zu decken mit		34) Versender-Nachname			
35) Anlagen [ ] Lieferscheine [ ] Pick-Up-Sheet (PUS/MAIS) [ ] Rechnungen [ ] Ausfuhrklärung [ ] DFÜ-WBS [ ] ATR [ ] Leergutschein				36) Auftrags-Nr. Kunde 77243		37) Kontierung			
43) Übernahmebestätigung des Fahrers: obige Sendung vollständig und in ordnungsgemäßem Zustand übernommen.  Datum _____ Uhrzeit _____ Unterschrift _____				38) Transportmittel-Nr. SO-AA-264		41) Abrechnungs-Schl.			
45) Es gelten die Allgemeinen Deutschen Spediteurbedingungen (ADSp). Gerichtsstand ist der Firmensitz des Versandspediteurs.				39) LKW-Code		42) Empfangsbestätigung des Warenempfängers: obige Sendung vollständig und in ordnungsgemäßem Zustand erhalten.			
2) Lieferanten-Nr.		(Platz für Barcodefelder)		8) Sendungennummer		44) Die Sendung enthält davon getauscht			
10) Spediteur-Nr. 250000001				10) Bodero-/ Ladefliste-Nr.		46) für Versender / Lieferant			

VDA 4902 v.3.03.234

**Achtung!** Sichtbare Schäden müssen auf den Frachtpapieren vermerkt und äußerlich nicht erkennbare Schäden innerhalb von 7 Tagen dem Spediteur schriftlich mitgeteilt werden.





7.4.2.3.3 Shipping list - DFÜ Warenbegleitschein (VDA 4912)

ERI GOODS ISSUE SLIP (VDA 4912)		TRANSPORT NO.: 6240305		12.01.2010 - 07:56		
SUPPLIER -PLANT: -NUMBER: 0000030005		RECIPIENT PLANT	1000	UNLOADING POINT: 1053		
Hella KGaA Hueck & Co. Fixbecker Straße 75 59552 Lippstadt / Germany		-NUMBER: 11610600		STOR. LOCATION: 1053		
		Hella Saturnus Slovenija d.o.o. Letalska Cesta 17 1000 Ljubljana		PT. OF CONSUMPT.:		
				SHIPPING TYPE: Truck		
				CARRIER: NordSüd		
				-NUMBER:		
				SHIPMENT-WEIGHT 5.968		
DN-NO.	SUP.REF.NR.	CUST.	QUANT.	UM	V/G DESIGNATION OF SHIPMENT	PURCH.ORD.NR.
-DATE	SUPPL.REF.NR.	VEND.			ADD. DATA SUPPLIER	
-POS	PACKAGING -QTY.	-NUMBER CUST.			FILLING QTY. -NUMBER VENDOR	CONSIGNMENT
85084010	16020100	AA	900,000	PC S /	COVER LENS LH	5500002902
12.01.2010	LES 160.201-007					
000010	VP:	18	47700200	X	50,000 477.002-00	
	VP:	900	27736204	X	277.362-04	
	VP:	72	47700202	X	477.002-02	
	VP:	18	82400176M	X	824.001-76M	
	load:		dang.goods:			
***** E N D *****						
85084011	16020200	AA	900,000	PC S /	COVER LENS RH	5500002903
12.01.2010	LES 160.202-007					
000010	VP:	18	47700200	X	50,000 477.002-00	
	VP:	900	27736204	X	277.362-04	
	VP:	72	47700202	X	477.002-02	
	VP:	18	82400176M	X	824.001-76M	
	load:		dang.goods:			
***** E N D *****						
85087401	00971500	AE	960,000	PC S /	ACTUATOR	5500002703
12.01.2010	6NM 009.715-007					
000010	VP:	12	47711300	X	80,000 477.113-00	
	VP:	1	47720000	X	0,000 477.200-00	
	VP:	48	48038770	X	480.387-70	
	VP:	12	47711309	X	477.113-09	
	VP:	24	47711304	X	477.113-04	
	VP:	1	48001765	X	480.017-65	
	load:		dang.goods:			
***** E N D *****						
85087404	16278613	AF	720,000	PC S /	PROJ. GR BI-XENON LES2 OPTIMO	5500002926
12.01.2010	1VL 162.786-138					
000010	VP:	3	47720000	X	240,000 477.200-00	
	VP:	3	48001765	X	480.017-65	
	VP:	48	48038562	X	480.385-62	
	VP:	96	48736013	X	487.360-13	
	load:		dang.goods:			
***** E N D *****						
85089075	27161700	AA	1 200,000	PC S /	COVER LENS LH	5500001956
GR:	QUANT. CHECK:		RATING CHECK:			





7.4.2.3.4 Delivery note (VDA 4991)

**Hella KGaA Hueck & Co.**  
Rixbecker Straße 75, 59552 Lippstadt/Germany



(5) account number at recipient 0000030005		(2) notices of receipt and processing				<b>DELIVERY NOTE</b> (3) No. 85089077 (4) date of dispatch 12.01.2010 Page 1 / 02	
Hella Saturnus Slovenija d.o.o.  Letalska Cesta 17  1000 Ljubljana SLOWENIEN		(6) freight		(7) inbound delivery			
customer number at supplier 11610600		free	not f.	waggon	carrier		
(10) your reference	(11) order No. 5500003031	date	(12) Our reference HD-AF	(13) direct dial 9831	(14) our confirmation 30054406		
(15) add. data of the order	(19) shipping-type Truck	(20) free not f.	(21) packing type	(22) disp. character	(23) gross total weight kg 8,0	(24) net weight kg 6,2	
(25) ship-to-address					(26) receiving-unloading pt 1053 1053		
(27) Pos.	(28) order No./suppl. ref No.	(29) order description (21) packing type (details)		(30) quantity	(31) DU	(40) Pos. quantity (is)	+ / - notes
10	INCOTERMS: EXW Erwitte Highest HU: 108823943 5DF 169.424-727 16942472 Cust. Engin. Change Status: AA HS-Code: 85371099 Country of origin: DE 112 PC in 108823943 Order number: 5500003031/09.04.2009 Our confirmation: 30054406	LED CONTROL (LDM)		112	1		
#	477.110-10 47711010	BOX A= 400X300X170		1	1		
#	477.110-01 47711001	INTERMEDIATE LAYER 355X255X3.5		8	1		
Total volume: 20,000 L		Purchase hereby agrees that any and all publication or use of Hella					
1	date	notices of receipt	quantity check	quality check/test report	recipient	invoice verific.	
2	name						
3	No.						

VDA 4991-10000

MTC  
1=ST  
2=kg  
3=mm  
4=mm  
5=mm  
6=mm  
7=mm  
8=mm

Origin reference: \* = no product of origin, two-digit letter sequence = country of origin as per 'list of countries for foreign trade statistics'.  
Gross prices are non binding recommended prices without VAT.  
Delivery is made at your expense and at your risk on the basis of the order in compliance with the conditions of delivery and payment as stated overleaf.  
All deliveries and services are carried out exclusively according to our terms and conditions of sale, delivery and payment, which can be found on the internet under <http://www.hella.com/agb> or can be requested from the clerk named above.  
Telephone No.: +49 (0) 29 41/38-0    Fax No.: +49 (0) 29 41/38-71 33    Internet: <http://www.hella.com>    Trade register: Local court Paderborn HRB 6857    Bank/Bankers: Deutsche Bank AG, Lippstadt, Acc.No. 8 085 013, BLZ 416 700 27 IBAN DE59 4167 0027 0608 5013 00 SWIFT DEUTDE 38416

### **7.4.3 Labeling**

Packaging material is marked according to the specifications set out in the contractual agreements.

#### **7.4.3.1 Standard**

HELLA uses the Global Transport Label (GTL) for material flow. Alternatively, a label in accordance with VDA recommendation 4902 version 4 can be used.

The VDA recommendation and the GTL requirements are valid in their full scope for the supplier, too. Deviations from this recommendation or information are not required.

All labels, test marks or similar supplier stickers must be removed when a new goods tag is attached.

#### **7.4.3.2 Attachment**

A goods tag must be attached to each load unit and each load carrier.

The goods tag is inserted into the document pocket/label holder provided on the container and can be secured additionally by an easily removable adhesive spot if necessary.

If there is no document pocket/label holder available, the goods tag must be attached to the document areas provided. If there is no document area defined on a load unit, the goods tag must be attached at the top right hand corner of the end of the load unit:

- Attachment is by means of adhesive spots at the corners of the goods tag.
- Other attachment points must be agreed between the supplier and HELLA.
- The adhesive spots must be attached in such a way that all the data boxes and barcodes remain legible.
- The goods tags must not cover the packing material ID of the packing material used.

HELLA is authorized to charge the supplier with the cost of removing any labels glued on over their whole surface.

#### **7.4.3.3 Single-level packaging structure – single-label**

In the case of single-level structure of a load unit, a specified quantity of the same materials are loaded on or in a load carrier.

These load units must be marked with a single-label.

#### **7.4.3.4 Double-level packaging structure – master-label and single-label**

In the case of double-level structure of a load unit, a specified quantity of the same materials are loaded in several load carriers on one loading aid unit. Load carriers are marked with a single-label, and the load unit has an additional master-label.

#### **7.4.3.5 Collective load unit (mixed consignment)**

If sorted load units cannot be formed e.g. because call-off quantities are low, materials with different part numbers can be combined to form one physical collective load unit. For this purpose, the individual part numbers must be packed in separate load carriers and given a single-label. The load unit is then given an additional G-label.

The different items in the load unit must be clearly visible on the goods tag. They must be listed individually in the documents accompanying the consignment and in the EDI message.



#### **7.4.3.6 Marking electronic components**

In order to standardize the traceability of electronic components, a MAT-label is used in addition to the single and master-labels. Traceability is guaranteed on material number level through a serial identifier. The complete information can be read out on the basis of the Data Matrix Code on the label.

If necessary, HELLA must provide the supplier with the specification for the MAT-label. Chapter 7.3.4.7.6 shows examples of the two types of standard label.



### 7.4.3.7 Examples

#### 7.4.3.7.1 Global Transport Label – Large / VDA format (210 x 148mm)

Area of usage: Europe

SHIP FROM <b>HELLA KGAA HUECK &amp; CO</b> <b>RIXBECKER STR. 75</b> <b>59552 LIPPSTADT</b> CONTACT <b>+49-2941-38-5364</b> MADE IN <b>GERMANY</b>		SHIP TO <b>SPEDITION HANSMANN</b> <b>MOERSERSTRASSE 6</b> <b>38442 WOLBSBURG-EHMEN</b> PLANT/DOCK <b>VWAG 11 101S9</b>			
SUPPLIER ID <b>261323</b> DELIVERY NO. <b>79342862</b>		POINT OF DELIVERY/USE <b>HL3</b> MATERIAL DESCRIPTION <b>SENSOR</b>		PACKAGING <b>VW0012</b> QUANTITY <b>270 PCS</b>	
PART NO. <b>1K1 723 503 N</b>					
LICENSE PLATE (6J)  <b>6J UN 324406669 518648697</b>				WEIGHT <b>195 KG</b> SHIP DATE <b>2009-12-31</b> REVISION LEVEL <b>E1243K</b> CHARGE <b>XXX</b>	
Supplier area				<b>MASTER LABEL</b>	

#### 7.4.3.7.2 Global Transport Label – Large / AIAG format (152.4 x 101.6mm)

Area of usage: worldwide (except Europe)

SHIP FROM <b>HELLA KGAA HUECK&amp;CO</b> <b>RIXBECKER STR. 75</b> <b>59552 LIPPSTADT</b> CONTACT <b>+49-2941-38-5364</b> MADE IN <b>GERMANY</b>		SHIP TO <b>SPEDITION HANSMAN</b> <b>MOERSERSTRASSE 6</b> <b>38442 WOLFSBURG</b> PLANT/DOCK <b>VWAG 11 101S9</b>			
SUPPLIER ID <b>261323</b> DELIVERY NO. <b>79342862</b>		POINT OF DELIVERY/USE <b>HL3</b> MATERIAL DESCRIPTION <b>SENSOR</b>		PACKAGING <b>VW0012</b> QUANTITY <b>270 PCS</b>	
PART NO. <b>1K1 723 503 N</b>					
LICENSE PLATE (6J)  <b>6J UN 324406669 518648697</b>				WEIGHT <b>195 KG</b> SHIP DATE <b>2009-12-31</b> REVISION LEVEL <b>E1243K</b> CHARGE <b>XXX</b>	
Supplier area				<b>MASTER LABEL</b>	



7.4.3.7.3 Global Transport Label – Small (210 x 74mm)







Area of usage: for small containers in Europe

SHIP FROM <b>HELLA KGAA HUECK&amp;CO</b> <b>RIXBECKER STR. 75</b> <b>59552 LIPPSTADT</b> MADE IN <b>GERMANY</b>		SHIP TO <b>SPEDITION HANSMAN</b> <b>MOERSESTRASSE 6</b> <b>38442 WOLFSBURG</b> PLANTTDOCK <b>VWAG 11 103S9</b>				WEIGHT <b>180 KG</b> SHIP DATE <b>2009-12-31</b> REVISION LEVEL <b>E1243T</b> CHARGE <b>XXX</b>	
SUPPLIER ID <b>261324</b>		POINT OF DELIVERY/USE <b>HL2</b>		PACKAGING <b>VW0014</b>			
DELIVERY NO. <b>79342863</b>		MATERIAL DESCRIPTION <b>SENSOR</b>		QUANTITY <b>120 PCS</b>			
PART NO. <b>1K1 723 503 F</b>							
LICENSE PLATE (U)  <b>6J UN 324406669 518648698</b>				Supplier area			



7.4.3.7.4 VDA master-label

Area of usage: Europe

1) Warenempfänger <b>HELLA KG HUECK &amp; CO</b> <b>59557 LIPPSTADT</b>		2) Abteilungs- Lagerort- Verwendungsschlüssel <b>1425</b>		3) Lieferchein-Nr. (R) <b>M</b>	
3) Lieferchein-Nr. (R) <b>85100123</b> 		4) Lieferantenanschrift (Kurzform, Werk, PLZ, Ort) <b>AUTO AG, 85000 Musterstadt</b>			
		5) Gewicht netto <b>40</b>	6) Gewicht brutto <b>110,5</b>	7) Anzahl Packstücke <b>8</b>	
8) Sach-Nr. Kunde (F) <b>005 918 -15</b> 					
9) Füllmenge (Q) <b>123</b> 		10) Bezeichnung, Lieferung, Leistung <b>HB5 12V 51W P24D</b>			
12) Lieferanten-Nr. (V) <b>123456</b> 		11.1) Sach-Nr. Lieferant (XIS) <b>9230 489 28935</b>			
15) Packstück-Nr. (S) <b>400001239</b> 		11.2) Packmittel-Nr. Kunde (E) <b>BOX1234</b> 		13) Datum <b>D100120</b>	
17) A AUTO AG, 85000 M Musterstadt		14) Änderungsstand/ Konstruktion <b>AA</b>		16) Chargen-Nr. (H)	
		Wareneinfänger VDA 4902 Vers. 4			

7.4.3.7.5 VDA KLT-label

Area of usage: for small containers in Europe

1) Warenempfänger <b>HELLA KG HUECK &amp; CO</b> <b>59557 LIPPSTADT</b>		2) Abteilungs- Lagerort- Verwendungsschlüssel <b>1425</b>		3) Lieferchein-Nr. (R) <b>85100123</b> 	
8) Sach-Nr. Kunde (F) <b>005 918 -15</b> 					
9) Füllmenge (Q) <b>123</b> 		10) Bezeichnung, Lieferung, Leistung <b>HB5 12V 51W P24D</b>			
12) Lieferanten-Nr. (V) <b>123456</b> 		11.1) Sach-Nr. Lieferant (XIS) <b>9230 489 28935</b>			
15) Packstück-Nr. (S) <b>400001239</b> 		11.2) Packmittel-Nr. Kunde (E) <b>KLT1234</b> 		13) Datum <b>D100120</b>	
		14) Änderungsstand/ Konstruktion <b>AA</b>		16) Chargen-Nr. (H)	

7.4.3.7.6 MAT-label

	Part.No.: <b>A2C5318163202</b>	Date Code: 20080222	
	Quantity: <b>40</b>	Index: 02	
	Add.Info:	Expiry D.: 20090221	
	Part Name: <b>Printed Circuit Board</b>	Moisture: N	
Ordering Code: A2C5318163202/02			
Supplier-ID	Package-ID	1. Batchnumber	2. Batchnumber
8328826	S0000000ABC01	010508 6	010508 7
Purchase: 754628	Shipping Note: 122584		
Manufacturer Part Number: GIT76883			
	Manufacturer Location		
	Sample City		
Supplier-Name			
Supplier Sample & Co.			
Supplier-Data			
	40132241-02-PCL		
PA2C5318163202@V8328826			

	Part.No.: <b>A2C5318163202</b>		
	Quantity: <b>40</b>		
	Index: 02		
	Add.Info:		
	Expiry D.: 20090426	Moisture: N	
Part Name: <b>Printed Circuit Board</b>		Date Code: 20080426	
Supplier-ID	Package-ID	1. Batchnumber	2. Batchnumber
8328826	S000000017787	010508 6	010508 7
Purchase: 754628	Shipping Note: 122584		
Ordering Code: A2C5318163202/02			
Manufacturer Location: Samplecity			
Manufacturer Part Number: GIT76883			
Supplier-Name: Sample Printed Circuits GmbH			
Supplier-Data: 40132241-02-PCL			
			



## 8 Process related general topics

### 8.1 Consignation & credit note

#### 8.1.1 Consignation

The supplier is the owner of the consignment goods and remains such until goods are picked by HELLA. The consignment goods are marked accordingly and stored in such a way that they can be identified at all times.

Unless otherwise agreed, the supplier delivers the consignment goods within the European Union according to the term of delivery "DDU" to the company grounds of the respectively agreed HELLA locations. HELLA provides the storage area for such a consignment store.

HELLA is authorized to pick consignment goods from the consignment store within the context of usual business. HELLA is authorized to pick and process goods from the consignment stock at any time for its own requirements and those of HELLA Group companies. HELLA picks goods from the consignment stock according to the FIFO principle. When consignment goods are picked, a purchasing contract is concluded between the supplier and HELLA with regard to these goods.

Further details are specified in an additional agreement between the supplier and HELLA.

#### 8.1.2 Credit note procedure

With the credit note procedure, HELLA uses a modern instrument for billing deliveries. This optimizes business relations through faster and less expensive processing.

Payment/preparation of credit notes is carried out for deliveries for the agreed orders or respective picks according to the prices and conditions agreed in the contract.

Exceptions to this can be special orders for samples, custom products, tools etc.. These orders are marked accordingly. HELLA expects separate billing from the supplier for these.

Further details are specified in an additional agreement between the supplier and HELLA.

Message/format	EDIFACT	VDA
Credit note notification	INVOICE	4908

### 8.2 Purchase commitment

In principle, HELLA has a purchase commitment for a period of four weeks for finished goods and a further four weeks for preliminary materials valid from the date of the last delivery schedule sent. This regulation only applies to materials that are manufactured exclusively for HELLA. There is no purchase commitment for materials that are not manufactured exclusively for HELLA. Deviating regulations can be agreed, depending on the supply class.

#### 8.2.1 Minimum purchasing quantities

Binding minimum purchasing quantities require a separate express agreement made in writing. If no such agreement exists, there are no binding minimum purchasing quantities.

#### 8.2.2 Delivery batch size

A fixed delivery batch size/order batch size is basically not accepted. The minimum delivery batch size corresponds to the smallest agreed packaging unit.



## **8.3 Engineering Change Management**

### **8.3.1 Changing the issue level**

When new parts are delivered and after a change in issue level, a clearly visible reference to the change must be attached to the shipment. This must include the customer part number, issue level, supplier stamp and date.

Required data:

- Change/New part
- Supplier
- HELLA material number – issue level
- Design and change level
- Date

### **8.3.2 Change in dispatch location**

Changes in the dispatch location e.g. through relocation of the manufacturing facilities to a different production plant belonging to the supplier or the establishment of a delivery store deviating from the previous location, must be communicated in writing to HELLA Purchasing, central transport logistics, the transport logistics of the plant, planning staff in the plant, load carrier planning, empties dispatch and the forwarding agent six weeks at the latest before the changeover comes into effect.

## **8.4 Deviation management**

### **8.4.1 Emergency management/Contingency plans**

To guarantee smooth manufacturing and supplies to HELLA, contingency plans must be drawn up, agreed with all those involved, published and updated permanently. If possible, the Failure Mode and Effects Analysis (FMEA) method must be used.

In the event of any problems (e.g. technical faults, capacity bottlenecks, quality problems), supplier management is obliged to introduce existing contingency plans and initiate corrective and preventative measures agreed with HELLA in such a way that the problems do not have a long-term effect on the supply guarantee of the downstream supply relations (HELLA - Customers).

In particular, contingency plans must be prepared for the following situations, and staff must be trained accordingly:

- Data processing backup
- Problems caused by power failure and/or in data cables
- Problems caused by labor disputes
- Breakdown in procurement of preliminary materials
- Problems in production (e.g. also caused by fire, flooding etc.)
- Capacity bottlenecks
- Quality problems

- Breakdown in dispatch handling
- Transport backup

The supplier must notify the HELLA receiving plant immediately of any problems. The respective contingency plan must contain measures and deadlines as well as the names of those responsible for eliminating the problem. The contingency plans developed by the supplier must be agreed with HELLA before the first delivery.

In addition, HELLA expects its suppliers to introduce measures which secure supplies in the above-mentioned exceptional cases. For this purpose, the supplier must keep safety stock or have a flexible production model. If it should be established that the agreed measures are not sufficient, HELLA reserves the right to demand that the supplier set up safety stocks. The supplier must present the backup measures during the logistics audit and has to disclose these to HELLA at any time on request.

Without a specific request being made, the supplier must demonstrate how the supply guarantee can be met in the event of problems. For this, the elements of risk minimization e.g. through safety stocks, alternative production etc. must be applied.

#### **8.4.2 Supply bottleneck**

The respective logistics staff at HELLA (usually the production location) must be informed immediately of any supply bottlenecks to be expected that affect deadlines or quantities.

Deviations from the delivery schedule (part deliveries, deliveries before the deadline or deviating quantities and additional deliveries) can always only be carried out following prior agreement with HELLA. Otherwise return transport will be arranged at the supplier's expense. This also applies in the event of obvious faults on transport carriers and transport containers.

In the case of supply bottlenecks through the supplier, he is obliged to guarantee maintenance of the production process at HELLA through part deliveries, extra tours and additional measures on his own production lines at his own expense. This also requires prior written agreement with HELLA. For the rest, the conditions defined in the skeleton delivery control for the procurement of production material apply. The agreements made in the respective consignment store contract are valid for the handling of consignment stores.

## **8.5 SOP & EOP management**

The section SOP & EOP management describes the cooperation between the supplier and HELLA in the case of new parts and part discontinuation. Implementation of the standardized procedures described in this section should avoid problems and achieve a plannable procedure. The exact implementation of this section is extremely important, since it makes efficient SOP and EOP at both the supplier's and HELLA possible.

### **8.5.1 Control of SOP for new parts in the Time to Market process (PEP)**

At HELLA, the SOP control procedure for new products is regulated in a standardized PEP. All the logistics requirements for the different phases of the PEP are defined and agreed together with the supplier before the first delivery.

Within the context of the PEP, the following points among others must be defined between the supplier and HELLA:

- Contact
- Schedule
- SOP curve/quantities
- Terms of delivery/supply class
- Billing
- Transport concepts
- Packaging concepts
- Data communication
- Documents to accompany the goods
- Capacities
- Directives, contracts and other agreements

Before the first delivery, the supplier must carry out a self-audit according to VDA/Odette Global MMOG.

### **8.5.2 SOP & EOP management in the case of changes**

If parts are changed, the series purchaser at HELLA informs the supplier. An SOP and EOP scenario is developed together with the supplier and taking purchase commitments into account. The result is communicated through the delivery schedule.

### **8.5.3 End of series production**

When a series is discontinued, detailed agreement is necessary between the supplier and HELLA. Sometimes the final call-off quantities required are smaller than the packaging unit agreed. The supplier is obliged to keep to these call-off quantities.

The supplier must guarantee that no tools are relocated or scrapped without agreement by HELLA. In addition, the supplier is obliged to guarantee the post-production delivery ability for the period agreed with HELLA after the end of series production.



## **8.6 Traceability**

If the event of a quality problem, HELLA must be able to trace information about the products used by the supplier right back to the origin of production. When HELLA quotes the batch number to the supplier, he must be able to determine the production conditions under which the parts concerned were manufactured.

He must always be able to inform HELLA of all the products/batches that have the same problem. Systematical mapping of the production batches is of fundamental importance. HELLA is authorized to check the adherence to the above requirements at any time in the form of an announced audit.

The supplier must guarantee adherence to the above conditions for his suppliers as well.

## 9 Data interchange

### 9.1 Electronic data interchange (EDI)

In HELLA's view, the ability to take part in Electronic Data Interchange (EDI) is an essential pre-condition for efficient cooperation with suppliers. For this reason, HELLA requires all suppliers to be able to transmit data using electronic remote data transmission (EDI) or use HELLA's WEB-EDI.

HELLA uses the globally valid **standard format EDIFACT**. The VDA format can be used in exceptional cases.

All EDI-relevant information is described in the EDI-Guideline. The parties conclude a separate EDI contract for technical and legal backup.

The supplier is responsible for all the hardware and software equipment necessary for EDI as well as for adaptation of his own IT-systems. Costs incurred to the supplier through this are borne by the supplier himself.

The supplier must take respective precautionary measures within the context of servicing and backup to avoid problems with electronic data transfer. In addition, an emergency solution must always be planned for every EDI solution, which must be agreed with HELLA and is part of a logistics audit.

### 9.2 WEB-EDI

As an alternative to the EDI procedure, HELLA provides suppliers with a web portal. In this case, all the information that is normally transmitted by EDI is provided to the supplier via the Internet.

In addition, documents accompanying shipments (delivery and transport documents/LuT) can be prepared via the web portal. If the supplier cannot generate these documents in his own system, he is obliged to generate these documents through the web portal.

Connection to the WEB-EDI is in accordance with HELLA's WEB-EDI documentation. This is provided on request. The supplier must bear any costs incurred by HELLA caused by deviations from these agreements.

### 9.3 Fax/E-mail

The use of fax or e-mail for conveying information is only an emergency solution in case communication through EDI or the web portal is not possible.

## 10 Logistics quality

This section explains to suppliers what HELLA requires and expects of them. On this basis, the supplier should understand the criteria according to which a logistics supplier evaluation is carried out by HELLA.

The supplier is committed to the **zero-fault target**. Alongside the technical zero-fault requirement that is applicable to the supplier's products, the target of HP-C-516 is to achieve zero faults in logistics. The logistics process quality according to VDA 5008 is the basic requirement for a smooth and problem-free material flow process and supports the following logistics claims:

- The right goods
- at the right time
- in the right place
- undamaged
- in the correct quantity
- in the correct packaging and with correct labeling
- with the respective information enclosed
- at logistics costs appropriate for the market

### 10.1 Malperformance claims towards suppliers

Faults caused by non-observance of this directive lead to additional costs at HELLA.

Costs incurred by HELLA due to logistics faults will be charged to the supplier according to the malperformance list. HELLA will charge the supplier for the work required to eliminate the fault according to expenditure incurred. The supplier is granted a period of 10 days after communication of proof of the expenditure incurred within which he can object to the planned charge in writing, specifying concrete proofs in the form of an 8D report. The costs incurred are charged automatically if no objections are made by the supplier within this period. At the same time, the logistics faults affect the supplier evaluation (section 10.2 of this directive).

### 10.2 Logistics supplier assessment

HELLA issues selected suppliers with an overall supplier evaluation (scorecard). The logistics evaluation is part of this overall supplier evaluation. It indicates the logistics efficiency and any required development by the supplier. Suppliers are obliged to improve continually. Suppliers with the status B or C in the logistics area in particular are required to achieve improvements at short notice to guarantee a reliable supply process chain.

### 10.3 Escalation levels

If the qualitative logistics requirements which HELLA makes on the products and materials of its suppliers are not met, the supplier is included in the HELLA escalation process. The escalation process for suppliers is described in quality directive HP-C 509 and should implement measures for avoiding quality or logistics problems. The supplier is assigned to one of three escalation levels, depending on the duration and severity of the problems that have occurred.

The three escalation levels result in different requirements depending on the supplier's classification

Level	Procedure
1	Preparation of an 8D report or plan of action
2	Check on this by HELLA on site at the suppliers in order to establish the appropriateness and effectiveness of the measures initiated by means of a quality and/or logistics audit
3	Securing the observance of the measures agreed by the supplier's business management, progress is monitored and documented through regular reviews

On level 1, the supplier must submit an 8D report to the logistics manager of the plant making the complaint within a period of 48 hours.

HELLA must be informed without delay of all potential risks to the customer-supplier relation by the supplier.

#### **10.4 Logistics audit**

HELLA reserves the right to carry out regular logistics audits at the suppliers to monitor and evaluate the logistics system inc. all logistics requirements from this directive. In this context, HELLA or a third party commissioned by HELLA has the right to audit the supplier with regard to system, process and product. The supplier must guarantee the auditing of his sub-suppliers through HELLA, a third party commissioned by HELLA or a HELLA client. The results of a logistics audit must be documented, including any planned or effectively implemented corrective measures, and be made available to HELLA at any time on request. Any deviations from this procedure must be agreed in writing between the partners when the contract is concluded.

## 10.5 List of possible logistics faults

No.	Fault type
1.	Faulty or incorrect EDI
2.	Faulty or incorrect freight papers
3.	Faulty or incorrect delivery notes
4.	Faulty labeling (labels attached in the wrong place, faulty label, illegible etc.)
5.	Faulty or incorrect marking of the containers/packaging units
6.	Faulty, incorrect or damaged packaging
7.	Delivery outside the defined delivery times and delivery locations
8.	Delivery without order
9.	Differences in quantities (short delivery/excess delivery)
10.	Non-observance of agreed min/max limits
11.	Schedule deviations
12.	Mix-ups (mixed goods in one container, difference between goods/label)
13.	Non-agreed type of delivery



## **11 Preliminary suppliers and production management**

### **11.1 Preliminary suppliers**

#### **11.1.1 Specification of procurement structure**

The selection of preliminary suppliers by the supplier must be carried out taking economic and quality-related aspects into account, in as far as the preliminary suppliers are not selected by HELLA. Basic logistics agreements must be made to guarantee permanent reliable deliveries.

The supplier must oblige his sub-suppliers to the same extent to observe the obligations taken over from this agreement.

#### **11.1.2 Evaluation of preliminary suppliers**

The evaluation of preliminary suppliers by the supplier during the Time to Market and series deliveries process is a major pre-condition for the recognition of weaknesses in good time and the agreement of suitable measures with the preliminary supplier. The supplier must analyze and evaluate his whole logistic process chain accordingly.

#### **11.1.3 Prevention of emergencies in the procurement of preliminary materials**

To prevent emergencies in the procurement of preliminary materials, the technical or commercial procurement alternatives that can be used must be listed. The supplier must define the period required and quantity possible for alternative procurement per product family. The stocks of semi-finished goods must be dimensioned depending on these criteria.

#### **11.1.4 Capacity and flexibility of preliminary suppliers**

The capacities and flexibility of preliminary suppliers must be shown transparently with clear criteria (shift models, capacity utilization, material stocks etc.) and agreed if necessary. The criteria must be reviewed at sensible intervals (particularly in the case of gradual changes in demand).

#### **11.1.5 Checking stocks of preliminary materials**

Care must be taken that the supplier can demonstrate complete transparency as far as the stocks of preliminary materials are concerned. For this, a permanent comparison of target and actual stocks must be carried out if possible. In addition to the quantity specification of stocks, evaluation must also be carried out e.g. in terms of range in working days (depending on production planning/customer delivery schedules).

#### **11.1.6 Determining the demand for preliminary materials**

The demand for preliminary materials must be determined on the basis of customer demand. The overall order horizon must be taken into account, so that the preliminary supplier also has a long-term requirements forecast available. The specification of order quantities takes place through assessment of materials requirements. This assessment of materials requirements includes all customers' delivery schedules (internal and external). The following criteria among others must be taken into account when scheduling requirement quantities:

- Lead times
- Internal and external production processing times
- Dispatch and transport times

### **11.1.7 Order handling**

In addition, it must be guaranteed that scrap replacements and special requirements are communicated to preliminary suppliers outside the usual order frequency as well. In as far as order handling with preliminary suppliers cannot be implemented by EDI, "paper handling" must be carried out with the same up-to-dateness and frequency and must be clearly documented. A complete electronic flow of information in the supply chain must be the target (elimination of media breaches).

### **11.1.8 Non-observance of delivery schedules by preliminary suppliers**

It must be agreed with preliminary suppliers that the customer is informed automatically if supply problems are to be expected. This agreement applies to both short-term bottlenecks and any recognition of longer-term problems with capacity.

### **11.1.9 Recognizing incorrect deliveries and quality problems**

The supplier must initiate suitable measures to recognize incorrect deliveries and material not up to the quality standard in good time, so that there is sufficient time available for procuring new material.

## **11.2 Production & storage**

### **11.2.1 Transparency regarding capacities**

Production Planning must ensure that there is permanent transparency of capacities of overall production, production lines and individual products taking all customer requirements into consideration.

If capacity is expected to be exceeded, HELLA must be informed without delay (reason, measure, quantity, date, start of CIP process) both by phone and in writing (fax, e-mail).

### **11.2.2 Dividing production capacities**

Sufficient manufacturing capacity must be provided for each part number/product family which is exclusively available for HELLA requirements. The critical capacity areas (production levels) per production line must be known and backed up (contingency plan).

### **11.2.3 Representation of flexibility with regard to possible increases in capacity**

The period (short, mid, long-term) during which increases in demand can be satisfied must be shown per part number/product family. For this, the necessary measures, time before use, possible application period, costs and increases in capacity achieved through these measures must be determined in percent.

### **11.2.4 Planning production supplies**

The supplier must ensure that there is no risk of mix-up during the supply of preliminary material, intermediate storage of semi-finished goods and storage of finished goods, and that the FIFO principle is used. Care must be taken that the supplier can demonstrate complete transparency for the stocks in circulation, in order to recognize in good time whether the current production requirements can be met or not.

### **11.2.5 Production management**

Once production has been commissioned, it must be guaranteed at all times that progress in production including scrap is transparent per production step. In addition, the processing times or remaining processing times must be evident.

### **11.2.6 Procedure in the event of production back orders**

It must be guaranteed that production back orders are recognized immediately and counter-measures are initiated.

### **11.2.7 Production in batch sizes**

In the case of production in batch sizes, the necessary flexibility in terms of short-term changes in customer requirements must be guaranteed. Batch sizes must be defined in agreement with customers, in particular during SOP and EOP situations (change requirements). The set-up and production times for one batch must be kept transparent. Reductions in set-up times (CIP approach) must be attempted in order to increase flexibility.

### **11.2.8 Storage**

The amount of finished material stored must be defined on the basis of delivery frequency and internal batch sizes. It is expected that the supplier can demonstrate complete transparency as far as the stocks of finished products are concerned. Care must be taken that there is no danger of mix-up during provision and storage of the material, and that the FIFO principle is applied.

## 12 Other

### 12.1 VDA recommendations

VDA recommendation 4902	Goods tags	<a href="http://www.vda.de">www.vda.de</a>
VDA recommendation 4905	Delivery schedule	<a href="http://www.vda.de">www.vda.de</a>
VDA recommendation 4912	Remote data transmission - goods issue slip	<a href="http://www.vda.de">www.vda.de</a>
VDA recommendation 4913	Remote data transmission of delivery note and transport data	<a href="http://www.vda.de">www.vda.de</a>
VDA recommendation 4913 VA 30,35,36,40	Stock and movement data	<a href="http://www.vda.de">www.vda.de</a>
VDA recommendation 4916	Call-off schedule/quantity call	<a href="http://www.vda.de">www.vda.de</a>
VDA recommendation 4922	Shipping order	<a href="http://www.vda.de">www.vda.de</a>

### 12.2 Mutually applicable documents

HELLA 7700	Packaging data sheet
HELLA 7729	Calculation of the circulating quantities of returnable packing material
HELLA 2907	Packing item comparison (difference notice)
HELLA 2908	Request form for packing items



### 12.3 Change documentation/Revision index

Revision date: (YYYY-MM-DD)	Person respon- sible	Change	Version num- ber